

Design and Development of Temperature Control System in Induction Furnace using LPC2148 and XBee

U. Rajkanna, K. Guna Sekaran, D. Manivannan and A. Umamakeswari
School of Computing, SASTRA University, Tamil Nadu, India

Corresponding Author: U. Rajkanna, School of Computing, SASTRA University, Tamil Nadu, India

ABSTRACT

In forging and rolling industries, the furnace is used for melting. The temperature of the furnace is controlled by supplying air-fuel combination, flow of electron, inflow of coal etc. Depends on the type of furnace it will vary. The temperature is measured by using pyrometer type sensors or any contact type sensors. Fully automated furnace, temperature is measured and transmitted to control room through a wired connection. Similarly control on furnace also carried out by wired connections from the control room. In wired network, transmission between control room and furnace and vice versa needs lengthy and confusing wire connections. Installation cost is also high. In this proposed study, the amplified value of the temperature sensor is transmitted to the controller unit by radio frequency waves. For transmission highly secured XBee is used. The controller unit receives the temperature serially by using another XBee module. The controller unit displays the temperature locally. Controlling value of the flow of electrons is transmitted to another controller using the XBee module. So that temperature of the furnace is maintained with $\pm 1^\circ\text{C}$. In the entire process LPC2148 processor is used. By implementing this technique accident due to operator carelessness can be reduced. This technique is easy to implement and also acquired at low cost.

Key words: Furnace, LPC2148, XBee, temperature, industries

INTRODUCTION

Furnace is a device used for heating purpose. They are mainly used in the industries to melt metals like aluminum, copper, gold etc. and also used to mold the materials. They used to extract materials from ores. This is implemented in oil refineries and other chemical plants. They also used to induce chemical actions. Different types of furnaces like oil furnace, gas furnace and electric furnace are available in industrial applications, its classification based on the method of heating the materials. Let consider induction furnace which falls under the type of electric furnace. Induction furnaces will not pollute the environment as that of other furnaces. In this method electric current is supplied to the induction coil. Current flow creates magnetic field in the coil, it induces eddy current in the work piece. This supplies heat to the work piece without any contact of an induction coil (Snaran *et al.*, 1982). Transmitting and receiving of measuring and control variables are wired. In the occurrence of fault in wires, it's difficult to identify. The furnaces used in small scale industries are not fully automated. So, it's dangerous and insecure to use and also consumes more energy when it operates. In this situation an idea is given to control the temperature of the furnace without human interference.

For this technique, Resistance Temperature Detector (RTD) is used to measure temperature. Some advantages of using RTD are easy recalibration and providing accurate and stable output.

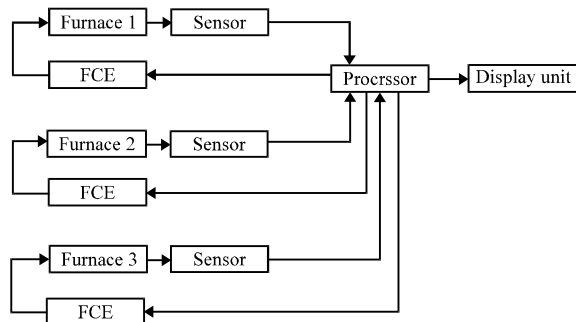

Fig. 1: Block diagram of a multiple furnace control system

Important features of the RTD are quick response to temperature change and linear for a wide range of temperature (Singh, 2009). They follow positive temperature co-efficient principle, in which resistance value is increased whenever temperature is increased. Their temperature measuring range is from -200 to 650°C . Using RTD Tin, Cadmium and Aluminium-Bronze melting temperature can be measured. After the measurement, temperature is transmitted to the controller unit through the wireless medium. In this work ZigBee technology (Shu-Guang, 2011) is used to replace Digital wireless telemetry circuit temperature system (Shengyong and Changzan, 2011). Depending on the received value from measuring unit, the control action is performed on the furnace by the controller.

All these data transfer actions are performed by wireless network. For wireless transmission XBee is used which is a low cost and low power communicating device. It transmits the data at the speed of 250 kb sec^{-1} and the operating frequency is about 2.4 GHz . It's operating voltage also very less of about 3.3 V . Fig. 1 shows the overall block diagram of multiple furnace control system. In processing unit LPC2148 is used to control the process. It is a 64 pin IC which has inbuilt ADC module, PWM, RTC, DAC etc. It consumes less power when compared to other processors. It follows RISC architecture and performs faster (Sloss *et al.*, 2004).

Final Control Element (FCE) has a direct influence on the process. It converts the electrical signal into mechanical action. So, that energy/mass goes in or out of the process is adjusted from the command given from the control unit. Common energy resources of FCE are pneumatic, electric and hydraulic (Johnson, 2003). For this process stepper motor (Austin, 2009; Kant, 2008) is considered actionable as FCE (Patranabis, 2006) which is controlled by LPC2148. The stepper motor is coupled with the potentiometer which is either linear or circular type. Rotation of stepper motor adjusts the resistance value, this resists the flow of electrons in inductive coils. This reduces eddy current flow in the surface of the materials, thus the temperature of the furnace is maintained.

PROPOSED WORK

In this proposed study, the entire process is divided into three units, they are Measurement unit, Control Unit and FCE unit. The measurement unit consists of sensors, Signal Conditioning Unit (SCU), LPC2148 and XBee. Furnace temperature is calculated from the sensor and transmitted it to control unit through XBee. Figure 2 indicates the general block diagram of Measurement unit. Control unit receives data from measurement unit and displays the value locally. The display unit may be of LCD or PC. Here PC is configured as a display unit. The controller also generates code depending upon the furnace temperature. Generated value is

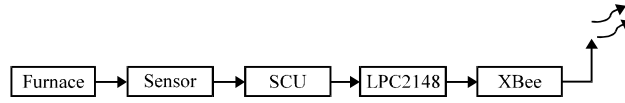

Fig. 2: Temperature measuring unit

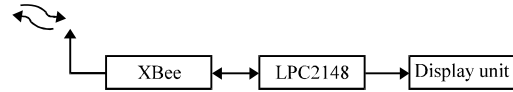

Fig. 3: Controller unit

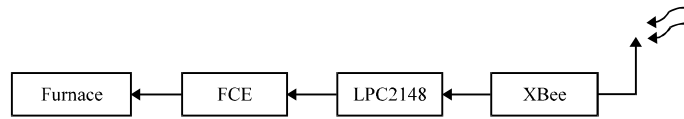

Fig. 4: Final control element (FCE) unit

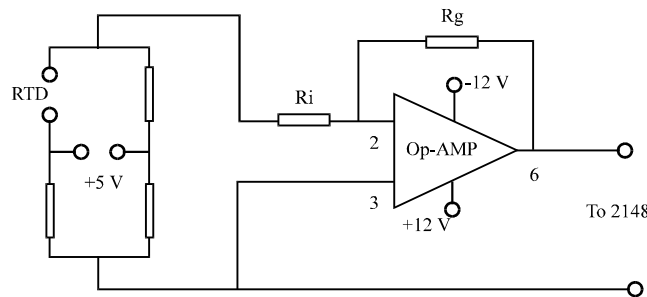

Fig. 5: Circuit for signal conditioning unit

transmitted to the FCE unit through XBee. Figure 3 indicates the general block diagram of a control unit. FCE receives the value through XBee and rotate stepper motor according to it. Stepper motor's revolution is decided by the processor in FCE depending upon the furnace temperature. Figure 4 indicates the block diagram of FCE unit.

In measurement unit, an RTD type sensor measures the temperature of the furnace. RTD is connected in one of the arms of a wheatstone bridge circuit followed by inverting amplifier (Fiore, 1999) is to be designed. This combination is said to be a signal conditioning unit. The Wheatstone bridge circuit is used to produce voltage with respect to the change in RTD. Amplifier circuit is designed in such a way that voltage level of temperature change should be in the range of (0-5) V. Depending upon temperature range, the inverting amplifier gain is to be calculated. Figure 5 is the signal conditioning circuit for temperature unit.

The analog value from SCU will be converted into a digital value by LPC2148 controller. Since it has inbuilt 10-bit ADC module, once the value is converted into digital, controller starts to transmit the value serially through an XBee module. It starts to transmit the data at the rate of 250 kb sec^{-1} to the coordinator in controller unit.

Initially configure the UART for serial transmission and ADC module in LPC2148. In ADC configuration selects the channel for Analog to Digital Conversion process and select the mode of data transmission. Configuration of ADC is done in A/D control register in which Burst mode is selected. The clock used for conversion, power up the mode and start of conversion are also to be configured in the control register. In UART configuration, it enables Divisor latch access and Tx and Rx pins and assigns VPB clock divider. Once the start bit is set in ADC, the processor starts to convert the analog value into a digital value. It waits for the end of conversion signal from the in-built module. After the conversion data is available in the ADC data register. The simple flow chart for measuring unit is shown in Fig. 6. Normally in temperature process there is no immediate response to temperature change. Only after certain time duration the change in temperature could be identified. So repeat temperature measurement for every 10 sec.

In control unit, the coordinator XBee receives the temperature value serially and transmits it to the controller. The controller displays the temperature reading locally. The controller decides stepper motor movement depending on the furnace temperature. It transmits the control code X or Y to FCE unit through XBee.

Control unit performs the operation such as data receiving, displaying, set point checking and control value transmission (Fig. 7). In this controller both UART's are configured for serial transmitting and receiving, it is similar to the measurement unit configuration. The processor LPC2148 waits for serial interrupt from XBee, once the interrupt is received, acquire the data from receiving buffer. Win XTalk or HyperTerminal window is used to view the output of the furnace (Fig. 8). Check the temperature value with set point, if temperature is higher than set point then assign the code value X and if temperature value is less than set point then assign the code value Y. The assigned code value is passed to FCE unit through XBee. If temperature and set points are equal, the processor should wait in the same position until the change in temperature is detected. Figure 9 indicates entire process flow chart of control unit.

In FCE unit the UART is configured for serially receiving data and PORT1 (P1) as an output port. The stepper motor is connected in P1 to the controller. This unit receives code from the controller unit through XBee. It checks whether received value is X or Y. If

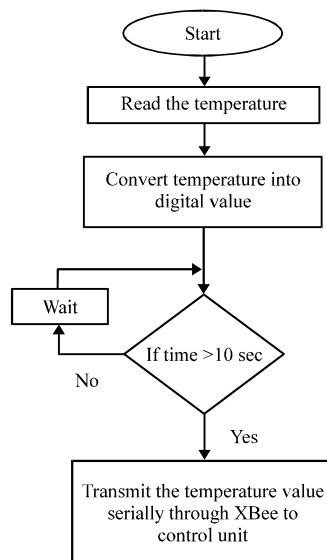

Fig. 6: Temperature measuring unit flow chart



Fig. 7: Experimental output of measurement and control unit

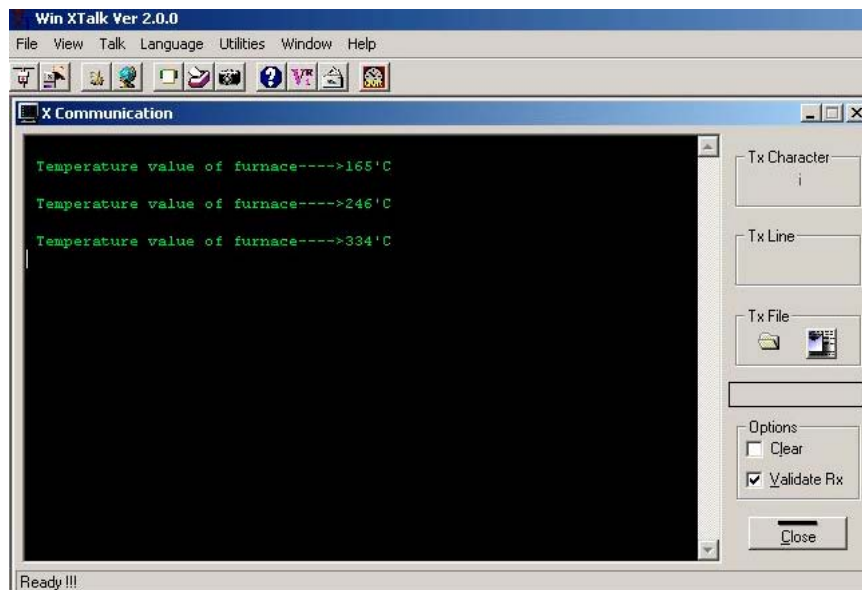

Fig. 8: Sample output of from control unit in Win XTalk

the code is X the stepper motor rotates in forward direction to increase resistor value, so that the temperature of the furnace is decreased. If the received code is Y then the stepper motor rotates in reverse direction this will decrease the resistance value so that the temperature value gets increased.

This section comprises the coding for stepper motor rotation and serially receiving the value from XBee. The operation of this loop fully depends on controller unit. Figure 10 indicates the operation of FCE unit.

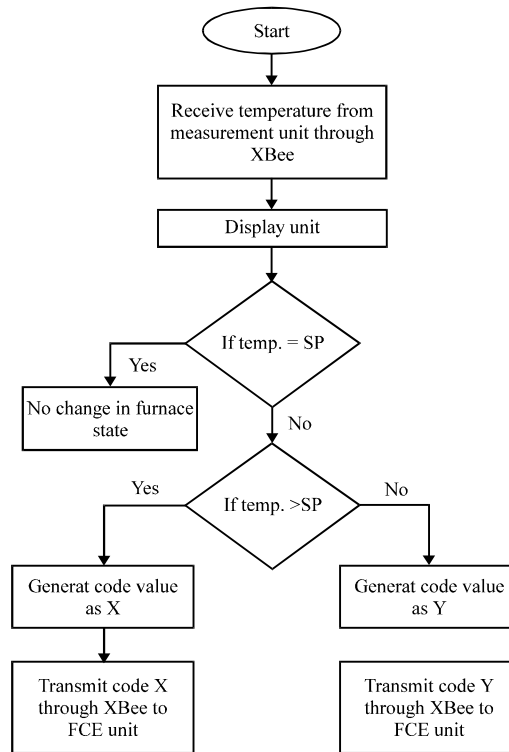

Fig. 9: Control unit flow chart

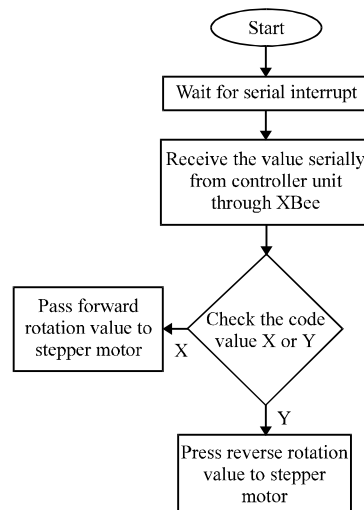

Fig. 10: FCE unit flow chart

In this technique low power consuming processor and communicating device is used. So, it can be implemented with battery power itself. This setup does not require more number of wires or complicated connections, so instantly placed in high temperature areas for control actions. More number of furnaces can be controlled with single processor. GSM can be implemented so that the supervisors or managers can analyze the furnace status by mobile itself. Some ARM core supports

web application, so that the furnace working can be monitored from outside also. This will be useful for education purpose. Keypad interfacing can be included for selecting set point.

CONCLUSION

This proposed study is easy to monitor and control the temperature of the furnace. This can also be implemented in small scale boilers too. It avoids separate control room and air conditioning unit and with the least amount of wire and power it can be implemented. Fault occurrence can be easily detected. This system suits for any type of sensors like Thermocouple, LM35 and Pyrometer etc.

ACKNOWLEDGMENT

The research has been supported by the research and modernization funded project of SASTRA University-R and M/0008/SOC-001/2009-10.

REFERENCES

- Austin, H., 2009. *Electric Motors and Drives: Fundamentals, Types and Application*. 3rd Edn., Publisher Elsevier, India, ISBN: 8131206688, pp: 305-323.
- Fiore, J.M., 1999. *Operational Amplifiers and Linear Integrated Circuits: Theory and Application*. 1st Edn., Jaico Publishing House, USA., ISBN13: 9788172247782, pp: 133-138.
- Johnson, C.D., 2003. *Process Control Instrumentation Technology*. 7th Edn., Prentice Hall of India Private Ltd., London, ISBN-10: 0130602485, pp: 321-360.
- Kant, K., 2008. *Computer Based Industrial Control*. 9th Edn., Prentice Hall of India Pvt. Ltd., New Delhi, pp: 259-262.
- Patranabis, D., 2006. *Principles of Process Control*. 2nd Edn., Tata McGraw Hill Publication Company Ltd., USA., pp: 242-246.
- Shengyong, Z. and S. Changzan, 2011. Digital wireless telemetry circuit temperature. *Proceedings of the IEEE International Conference on Control, Automation and Systems Engineering*, July 30-31, 2011, Singapore, pp: 1-3.
- Shu-Guang, M.A., 2011. Construction of wireless fire alarm system based on ZigBee technology. *Procedia Eng.*, 11: 308-313.
- Singh, 2009. *Industrial Instrumentation and Control*. 3rd Edn., Tata McGraw Hill Publication Company Ltd., USA., ISBN: 0070262225, pp: 420-422.
- Sloss, A.N., D. Symes and C. Wright, 2004. *Arm System Developers Guide: Designing and Optimizing System Software*. Elsevier/ Morgan, USA., ISBN: 1558608745, Pages: 689.
- Snaran, R., S.N. Prasad and N.D. Saksena, 1982. *Forging Die Design and Practice*. Publisher Chand, UK., pp: 183-188.