

Entrepreneurship Midwife: Competence and Performance Work Environment as Determinant

¹Endang Suswati, ¹Dwi Winarno and ²HMS. Idrus

¹Faculty of Economics and Business, University of Gajayana Malang, East Java, Indonesia

²University Brawijaya, Malang, East Java, Indonesia

Abstract: The purpose of this study to examine the effect of entrepreneurial competencies of midwives to midwives, midwives examine the effect of entrepreneurship on the performance of midwives, midwives competency test the effect on the performance of midwives and examine the effect of the work environment on the performance of midwives. The study was conducted in Banyuwangi with method survey of midwives who opened a private practice/self, sampling method using purposive sampling method with a sample of 153 midwives. Analysis tool used is Structural Equation Modeling (SEM). The results of the analysis in this study were first entrepreneurial midwives have a positive and significant impact on the competence of midwives, midwives second entrepreneurship has a positive and significant effect on the performance of midwives, midwives third competency has a positive and significant effect on the performance of midwives, the fourth positive work environment has an influence and significant impact on the performance of midwives.

Key words: Entrepreneurship, midwife, competence, working environment, performance midwife

INTRODUCTION

Midwives as one birth attendant is one of the important factors in determining the health, safety infant and maternal. Advancement of the health status of the population can be seen from several indicators, among others, the Infant Mortality Rate (IMR), life expectancy and helper mother during labor and delivery. These three indicators are affected directly or indirectly by several socio-economic variables.

Most of the babies birth attendants by midwives (58%) and shaman (25.31%), the rest by other medical personnel. According to the type of area which is the highest birth attendants in urban and rural areas, namely by midwives, respectively 65.81 and 52.22% in the city in the village. Tabloid Midwife/Mas stated 51.9% childbirth at home was much assisted by a midwife.

A midwife who opened an independent practice can be called as an entrepreneur. Where the entrepreneur is a person who has the expertise to sell, began offering up to the idea of commodities namely services. In East Java, the number of midwives practice independently and has been certified DIII midwifery around 70% while that is not 30% the number of midwives in East Java, there are 11,000 midwife means there are 3,300 midwives who do not have a diploma DIII midwifery, said the chairman of the

Indonesian Midwives Association of East Java. Whereas, the government requires to all midwives to have DIII midwifery diploma.

Lydia in Indonesia currently has existed for >700 educational institutions D-III Midwifery. However, the development of the D-III Midwifery Program so rapidly fact has not been able to answer the challenge of a competent midwife. Various studies show that the quality of graduates produced midwife can not meet the demands of quality midwifery service.

The results of the interview with the Chairman of the Indonesian Midwives Association Banyuwangi (Werdiningsih, 2014). Midwives who opened a private practice/self if you want to be a qualified midwife and the midwife must work in totality and must be willing to change to continually improve performance if not changed, should be left.

Globalization requires qualified midwife because midwives in private practice must be qualified. Professionalism demands absolute midwives to be met, the Indonesian Midwives Association (IBI) course should always improve the competence of its members so that they are able to adjust in accordance with the standard of care in the community. Midwives not only as health workers attending births only but also midwives should be able to become an entrepreneur because being an

entrepreneur will empower potential midwife and also empower others, growth and development of midwives entrepreneur can create jobs, reduce unemployment and increase purchasing power.

Level of community needs more qualified to obstetric care should also be anticipated to improve the skills and competencies of midwives. Midwives must be qualified, professional and ready to use in the community. The success/failure of entrepreneurs is highly dependent on the ability of private entrepreneurs (Suryana, 2003). Several studies have shown that companies with entrepreneurial orientation tend to be more successful (Kropp *et al.*, 2006). Problem formulation of this research are:

- Is a midwife entrepreneurship have an influence on the competence of midwives?
- Does the entrepreneurial midwives have an influence on the performance of a midwife?
- Does the competence of midwives have an influence on the performance of a midwife?
- Is the work environment has an influence on the performance of midwives?

Review of theory

Entrepreneurship: Entrepreneur (entrepreneur) is a spirited person willing to take the risk to start a business in a variety of occasions. Spirited dare to take risks means independent minded and dare to start a business without overwhelmed with fear or anxiety even under conditions of uncertainty. Entrepreneurship is a creative and innovative capabilities that form the basis of tips and resources to find opportunities for success (Suryana, 2003).

Alma (2004) states the term entrepreneurship comes from the translation of entrepreneurship which means an ability to think creatively and innovative behavior as the basis, resources, propulsion, destination tactics, tips and process in the face of life's challenges.

Zimmerer and Scarborough (2005) "Entrepreneurship is one WHO creates new business in the face of risk and uncertainty for the purpose of achieving profit and growth by identifying significant opportunities and assembling the necessary resources to capitalize on them". The concept of entrepreneur is a person who creates new business in the face of risk and uncertainty in the future to grow and profit by identifying opportunities and using all available resources that contribute significantly to their business.

Some understanding of entrepreneurship can be concluded that entrepreneurship has some important things include creative thinking, behaving innovation as a driver/motivation, willing to take risks and be ready to face the challenge. Attitude and entrepreneurial spirit is not only owned by entrepreneurs but also can be owned by any person who is creative and innovative thinking both the businesses and the general public.

Entrepreneurship midwives: Midwives who have completed a minimum of DIII midwifery education (Diploma of Midwifery) can perform entrepreneurial midwife. A midwife who opened a private practice/self can be referred to as an entrepreneur. Expected midwife will be able to provide appropriate health care professional and is able to manage a professional service management as well as having entrepreneurial spirit.

Competence: Competence according to Law No. 13/2003: Article 1 (10) states that: "Competence is the ability of each individual that includes aspects of knowledge, skills and attitudes that research in accordance with established standards". Whereas competence according to the Decree of the Minister of Education the number 045/U/2002. College core curriculum suggests "Competence is a set of intelligent action, the full responsibility of a person as a condition to be considered capable by the community in carrying out tasks in certain occupations".

According to Hariss (2000), competence is "are the underlying bodies of knowledge, abilities, experiences and other requirements necessary to successfully perform the job". Successful entrepreneurship in general is a market that has the competence, namely: who has the knowledge, abilities, skills and individual qualities needed to do the job.

Employees with the development of human resources both expected to have the competencies required to work in the company. The competence allows employees to perform their jobs effectively and efficiently which makes employees feel their work becomes easier with satisfactory results. Of course this is either directly or indirectly will affect the performance and commitment of employees (Scott-Ladd *et al.*, 2006).

Environment: Any company that wants to have a strategic competitiveness, should proactively look for patterns that can assist in understanding the business environment well. Environmental factors can affect the course of the business/company can be categorized as environmental factors micro and macro environment (Suryana, 2003).

Environmental microenvironment is no direct link with the company's operations such as suppliers, employees, shareholders, employers, managers, directors, distributors, customers/consumers. Medium macro environment is the environment outside the company that could affect the company's overall vitality.

The internal environment: The internal environment is directly related to the various parties to the daily activities of an organization and a direct affect on each program, policy, until the pulse of the organization (employees, management, corporate culture) (Daft, 2012).

The external environment: The external environment includes variables outside of the organization that may be common pressures and trends in the environment. The external environment includes variables outside of the organization that may be common pressures and trends in the environment or specific factors that operate in a working environment (social factors, economics, law/politics, technology and nature).

Performance: Performance is the result of the quality and quantity of work achieved by an employee in carrying out their duties in accordance with the responsibilities assigned to him Mangkunagara (2005), performance by Ilyas (2001) is the appearance of the work of both the quantity and quality of personnel within an organization. Performance can be an individual or group performance of personnel working. The appearance of the work is not limited to personnel who assumed office functionally and structurally but also to the whole range of personnel within the organization.

Based on the Decree of the Minister of Health No. 900/ Menkes/SK/VII/2002 on the registration and practice midwife and performance the notion: Midwife performance is achieved by the work of midwives in performing their duties related to the quality of maternal and child health services consist of scope: antenatal care (before birth), scope of service delivery, postpartum and neonatal care coverage (after birth) including the activities of recording and reporting activities in accordance with the services provided.

Research hypothesis: The hypothesis in this study as follows:

- Entrepreneurship midwife affect the competence of midwives
- Entrepreneurship affect the performance of midwife midwife
- Competence midwife affect the performance of midwives
- The work environment affect the performance of midwives

MATERIALS AND METHODS

Types of research: This study is based on an explanatory research with survey method. The population of this study is independent midwives practicing in Banyuwangi East Java as one of the growing district human resources in health. Sampling method using purposive sampling method by means of sending and giving directly to the respondents in Banyuwangi which has been determined. According to statistical data and information Chairman of the Indonesian Midwives Association Banyuwangi 2014, the number of midwives in Banyuwangi District Health Office 250 midwives. Researchers in determining the justification of the sample using the formula according Slovin Umar (2003). Total population of 250 midwives, alpha (α) of 5%, the number of samples in this study amounted to 153 midwives.

Variables research: In brief, the study variables are summarized in Table 1. Questionnaires were distributed using a Likert scale model with five attitude scale from (1) strongly disagree to the scale (5) strongly agree.

Analysis tools

Descriptive statistics: Descriptive statistics were used to provide an overview of the survey respondents and a description of the research variables in the form of frequency description.

Testing data research: To test the data in this study is consistent with the problem, use statistical tools to

Table 1: Variables research

Variables	Indicators	Sources
Entrepreneurship midwife	Creative thinking, behavior of innovation, activator/ motivation, dare to take risks, ready for the challenge	Pearce and Richard (2008), Suryana (2003) and Alma (2004)
Competence	Knowledge; experience; skill; training; work attitude	Hariss (2000) and UU Ketenagakerjaan
Work environment	Internal and external environment environment	Daft (2012) and Pearce and Richard (2008)
Performance	Coverage of antenatal care, delivery care coverage coverage of neonatal care	Robbins and Judge (2009), Kinerja badan (SK Menteri Kesehatan RI No. 900/ MENKES/SK/VII/2002)

Structural Equation Modeling (SEM) is an integrated approach between the factor analysis, structural models and path analysis.

RESULTS AND DISCUSSION

Fit analysis model: The test results for the full model fit in this study are listed Fig. 1 and Table 2-7. In this study, established a relationship model that asserts that the relationship between observed variables.

Based on Table 2 there is a causal relationship observed 4, i.e., between entrepreneurship midwives (X1) to competence midwives (X2) and between entrepreneurship midwives (X1), competence midwives (X2) and the working environment (X3) on the performance midwives (Y1).

Table 2: Causal relationship between variables

Variables	Std. Estimate	SE	CR	p-value	Information
X2 <---X1	0.700	0.159	5.371	***	Sig.
Y1 <---X1	0.310	0.136	2.290	0.022	Sig.
Y1 <---X2	0.555	0.113	4.058	***	Sig.
Y1 <---X3	0.344	0.378	2.260	0.024	Sig.

Table 3: Results of test of goodness of fit model (final)

Goodness of fit index	Cut of value	Results	Information
Chi-square	<chi-sq 5%	121.959	Model marginal fit
Probability	>0.050	0.001	Model marginal fit
CMIN/DF	<2.000	1.564	Model fit
RMSEA	<0.080	0.061	Model fit
GFI	>0.900	0.908	Model fit
AGFI	>0.900	0.858	Model marginal fit

Data processed, 2014

Based on the test the suitability of the model (fit model), it is known that this research model is fit because it meets the test index is based on the rule of thumb that is required. That is, the model can be tested empirically used in this study. A summary of the test results are listed in Table 3.

In Table 3 obtained value of Chi-square count of 121.959 and a probability value of 0.001. Chi-square count value that is greater than the value of Chi-square table (121.959 > 108.648) or smaller probability value of alpha 5% (0.001 < 0.050) states that the hypothesis H₀ is rejected ie the sample covariance matrix is different from the estimated covariance matrix or can said that the model used is quite good or marginal fit but better than the previous model.

Table 4: Entrepreneurship midwives (X1) to competence midwives (X2)

Variables	Estimate	SE	CR	p-value	Information
X2 <---X1	0.700	0.159	5.371	***	Sig.

Table 5: Entrepreneurship midwives (X1) on the performance of midwives (Y1)

Variables	Estimate	SE	CR	p-value	Information
Y1 <---X1	0.310	0.136	2.290	0.022	Sig.

Table 6: Competence midwives (X2) on the performance of midwives (Y1)

Variables	Estimate	SE	CR	p-value	Information
Y1 <---X2	0.555	0.113	4.058	***	Sig.

Table 7: Working environment (X3) on the performance of midwives (Y1)

Variables	Estimate	SE	CR	p-value	Information
Y1 <---X3	0.344	0.378	2.260	0.024	Sig.

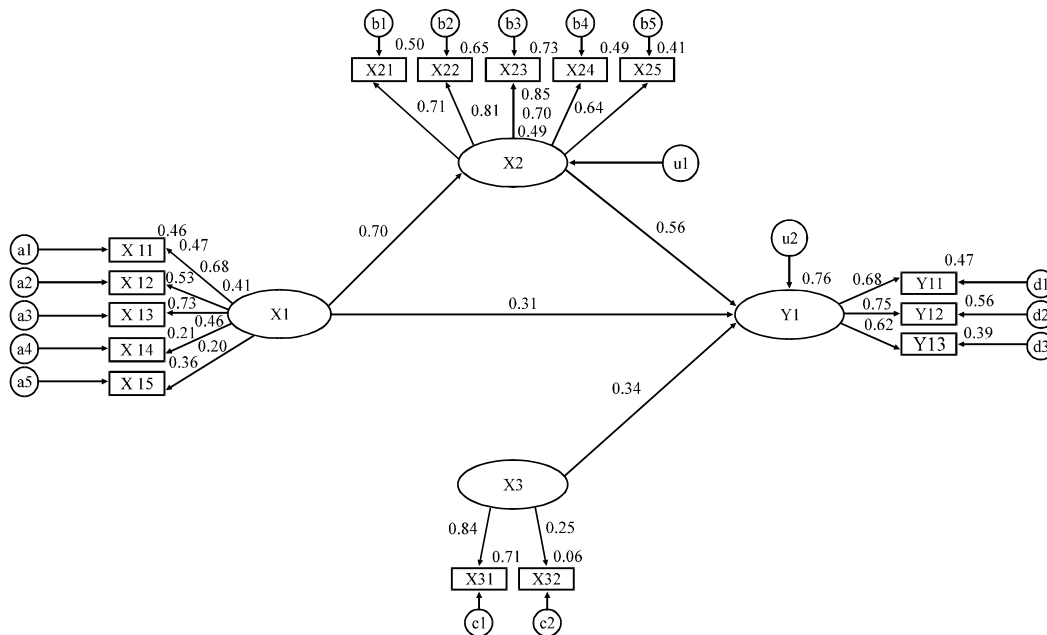

Fig. 1: Structural diagram. Description: X1: Entrepreneurship midwife; X2: Competence; X3: The work environment and X4: Performance midwife

RMSEA value of 0.061 is < 0.080 ; GFI values of 0.908 and 0.858 for AGFI value approaching the value of 0.900 indicates that the model used is a model of good or fit.

Hypothesis testing: Based on the results of statistical tests that have been used, all hypotheses are tested to meet the requirements or can be used as a measurement model in this study. Based on the results of hypothesis testing, presented the following results.

First hypothesis testing: From the results of analysis there is a positive relationship with the coefficient parameter (0.700) and significantly between entrepreneurship midwives (X1) to competence midwives (X2) because it has a value of t statistic (5.371) is greater than t table (1.960), then H_0 is rejected and it can be concluded that there is a positive and significant influence between entrepreneurship midwives (X1) to competence midwives (X2) with fault tolerance (alpha) of 5%. Directions positive relationship states that the higher factor midwives entrepreneurship (X1) will increase the competence factor midwives (X2). The level of confidence in the states there is the influence of the relationship is equal to 100-0% or at 100% Table 5.

Second hypothesis testing: From the results of analysis there is a positive relationship with the coefficient parameter (0.310) and significantly between entrepreneurship midwives (X1) on the performance of midwives (Y1) because it has a value of t statistic (2.290) is greater than t table (1.960), then H_0 is rejected and it can be concluded that there is a positive and significant influence between entrepreneurship midwives (X1) on the performance of midwives (Y1) with fault tolerance (alpha) of 5%. Directions positive relationship states that the higher factor midwives entrepreneurship (X1) will improve performance factor midwives (Y1). The level of confidence in the states there is the influence of the relationship is equal to 100-2.2% or by 97.8% Table 6.

Third hypothesis testing: From the results of analysis there is a positive relationship with the coefficient parameter (0.555) and significantly between competence midwives (X2) on the performance of midwives (Y1) because it has a value of t statistic (4.058) is greater than t table (1.960), then H_0 is rejected and it can be concluded that there is a positive and significant influence between competence midwives (X2) on the performance of midwives (Y1) with fault tolerance (alpha) of 5%. Directions positive relationship states that the higher the competence factor midwives (X2) will improve

performance factor midwives (Y1). The level of confidence in the states there is the influence of the relationship is equal to 100-0% or at 100%.

Fourth hypothesis testing: From the results of analysis there is a positive relationship with the coefficient parameter (0.344) and significant between working environment (X3) on the performance midwives (Y1) because it has a value of t statistic (2.260) is greater than t table (1.960), then H_0 is rejected and it can be concluded that there is positive and significant relationship between the working environment (X3) on the performance of midwives (Y1) with fault tolerance (alpha) of 5%. Directions positive relationship states that the higher factor working environment (X3) will improve performance factor midwives (Y1). The level of confidence in the states there is the influence of the relationship is equal to 100-2.4% or by 97.6%.

Entrepreneurship midwivesfor midwives competence: Based on Table 4 the results of hypothesis testing, results of this study in line with the results of research conducted by Nicolae and Neagu (2009) states that the dynamic changes in the economy affect the lives of human resources in entrepreneurship have the mindset to always innovate in modern organizational life. Am, entrepreneurs always involves success and competence in solving problems or conflicts faced, meaning that an entrepreneur to achieve success must have the competence to achieve success not only in business life but even in private life.

Midwife entrepreneurship research results related to the competence, supported by the opinion of Makhamreh (2000) successful entrepreneurs are entrepreneurs who have the competence are entrepreneurs who have knowledge skills and the quality of the individual. Boore and Porter (2011) describes the importance of the nurses got entrepreneurship education. At the point of learning outcomes (learning outcomes) are nurses statement can think creatively and act innovatively.

In related research entrepreneurial midwives, midwives always described on creative thinking for new ideas relating to the practice of midwifery successful because the midwife is the usual midwife creative thinking. Midwives are expected to have insight and future outlook. Van Dam *et al.* (2010) wrote that the research results of individual entrepreneurial competencies related to the behavior of entrepreneurs. Especially, adaptable and creative thinking. This strengthens the entrepreneurial research midwife ready for the challenge. Considers the problem as an opportunity not easy to give up and have the persistence task as a midwife who entrepreneurship.

Entrepreneurship midwives for midwives performance:

Based on Table 5 of the hypothesis testing results, results of this study agree with the results of a study Zahra and Covin (1995) which states that for several years the company organization to obtain information from top management and researchers, companies in which we operate as entrepreneur must always develop themselves in order to still be able to trust to be willing to take risks, innovate, act aggressively to compete as a key element of the organization and helps identify in improving performance, pursuing the benefits of the product and market opportunities and competitive advantages. Pearce and Richard (2008) and Navahandi and Malekzadeh (1997) suggests that the performance of a business is affected by factors characteristic of entrepreneurship, strategy and business environment Fort and Voltero (2004). There are five basic factors that affect the performance of midwives (advanced practice) and nurses in Armenia, namely the expectations of workers, performance feedback, environment and tools that support, incentive and motivation as well as skills and knowledge.

Competence midwife midwife to performance: On based Table 6 the results of hypothesis testing, competence midwife consisting of knowledge, experience, skills/skill, training and work attitudes affect the performance of midwife midwife. The midwife's performance with regard to services provided midwife associated with antenatal care/prenatal, service delivery and service after the birth. From the test results and data processing to prove that the better the performance of midwife midwife competence in providing services to patients also getting better.

Mitchelmore and Rowley (2010) put forward the theory of competence for successful leaders in which they change their behavior, attitudes and skills into more measurable aspects and find a way to achieve superior performance. Skills needed to become a successful entrepreneur. No exception to the midwife. Necessary skills are communication skills with good interpersonal skills and (Mitchelmore and Rowley, 2010). As a service provider, midwives are required to have good communication skills in order to provide outstanding service and maintain good relationship with the patient.

Sumodinoto (1996) factors that affect the performance of midwives, midwives is competence. or the ability to carry out the task, especially maternal and child health services, consisting of antenatal care coverage (before birth), service delivery, neonatal care after birth, tools and work equipment, rewards, attitudes and behaviors among personnel in the work environment and leadership.

Makhamreh (2000) stated that environmental factors, leadership and organizational and managerial influence on the success of the company's performance. Scott-Ladd *et al.* (2006), employee with good human resource development are expected to have the competencies required to work. The competence allows employees to perform their jobs effectively and efficiently make employees feel their work becomes easier with satisfactory results. Of course, this is either directly or indirectly will affect the performance of the employee.

Midwives who have good competence will improve the performance, the performance is not only personally but also the performance of the company/place of practice. This is supported by Mitchelmore and Rowley (2010) which states entrepreneurial competencies to support the company's performance and development of the economy. Peltier *et al.* (1999) the patient's perception of the ability of obstetric care experience on the performance of the doctors and nurses. The results obtained and the ability of obstetric care experience affect their performance in patient care. With good service performance will satisfy the patient with the patient satisfaction will be embedded in long-term patient loyalty.

Bosma and Fatoki (2014) argued specific competencies entrepreneurs positively affect the performance of the company. Research Bosma and Fatoki (2014), focuses on three measurements of managerial competencies that (level of education, work experience and experience related to the current work). Similar to the results of research on the competence of the performance of midwives, the results demonstrate knowledge and midwifery education, experience/duration become a midwife and the experience of practicing midwives affect the performance of midwives. The higher the level of education of midwives, the more aware and understand problems related to midwifery. Education here is not only formal education, informal education as well as training can improve the competence of midwives.

Experience dealing with delivery care, lead delivery and duration/length becomes midwife can improve performance. The more experience of the easier to overcome the problems encountered in practicing midwife. good indicator of the performance of actions reflected midwife midwives in providing services to patients before birth at birth and after birth.

The work environment on the performance of midwives:

Based on Table 7, the results of hypothesis testing, Fort and Voltero (2004) study with the aim to explain the factors underlying factor that affects the performance of midwives (advanced practice) and nurses in Armenia that

performance feedback, a supportive work environment, incentive and motivation as well as the skills and knowledge. The results show that a supportive work environment has a strong influence on the performance. Navahandi and Malekzadeh (1997) and Pearce and Richard (2008) suggests that the performance of a business and the business environment is influenced by factors entrepreneurial characteristics.

The results of this study agree with the results of research conducted by Lumpkin and Dess (2001) which states that entrepreneur orientation has five dimensions of autonomy, the behavior of innovation, risk-taking, proactive, aggressive in competing, dimension the dimension of influence on the performance of companies with environmental variables as variable link. Environmental characteristics of the dynamic effect on higher performance.

CONCLUSION

Entrepreneurship midwife has a positive and significant impact on competence. It is clear that the higher the self-employed midwives entrepreneurial orientation of the more competent.

Entrepreneurship midwife has a positive and significant effect on performance. This suggests that the self-employed midwives, the higher the orientation entrepreneurial the higher level of performance in fulfilling their duties.

Competence has a positive and significant effect on performance. It is clear that the higher the competency of the midwife, the higher the performance.

The work environment has a positive and significant impact on performance. It is clear that the better the working environment there is the higher the performance.

Entrepreneurship midwife, competence as well as an environmental good work it will be able to improve the performance of midwives.

SUGGESTIONS

In an effort to improve the entrepreneurial midwives, midwives should continue to develop in enhancing creativity and innovation.

In an effort to improve the competence, the midwife should continue to increase knowledge, skills/skills, education and training activities as well as seminars and workshops.

In order to improve the quality of midwifery services are excellent and the midwife should continue to improve the knowledge about the excellent service quality. There should be a follow-up study which took similar them.

REFERENCES

- Alma, B., 2004. Entrepreneurship. Alfabeta, Bandung, Indonesia.
- Boore, J. and S. Porter, 2011. Education for entrepreneurship in nursing. *Nurse Educ. Today*, 31: 184-191.
- Daft, R.L., 2012. *New Era Management*. Salemba Four, Jakarta, Indonesia.
- Fatoki, O., 2014. The impact of managerial competencies on the performance of Immigrant-owned enterprises in South Africa. *Mediterr. J. Soc. Sci.*, 5: 141-144.
- Fort, A.L. and L. Voltero, 2004. Factors affecting the performance of maternal health care providers in Armenia. *Hum. Resour. Health*, Vol. 2. 10.1186/1478-4491-2-8.
- Hariss, M., 2000. *Human Resource Management: A Practical Approach*. 2nd Edn., Dryden Press, USA., ISBN-13: 9780030259722, Pages: 528.
- Ilyas, 2001. Performance theory, assessment and research. Center for Health Economic Studies Faculty of Public Health, University of Indonesia.
- Kropp, F., N.J. Lindsay and A. Shoham, 2006. Entrepreneurial, market and learning orientations and international entrepreneurial business venture performance in South African firms. *Int. Market. Rev.*, 23: 504-523.
- Lumpkin, G.T. and G.G. Dess, 2001. Linking two dimensions of entrepreneurial orientation to firm performance: The moderating role of environment and industry life cycle. *J. Bus. Ventur.*, 16: 429-451.
- Makhmreh, M., 2000. Corporate performance in Jordan: A study of the banking sector. *Arab Bank Rev.*, 2: 40-48.
- Mangkunagara, A.P., 2005. HR performance evaluation. Teens Rosda Paper, London.
- Mitchelmore, S. and J. Rowley, 2010. Entrepreneurial competencies: A literature review and development agenda. *Int. J. Entrepr. Behav. Res.*, 16: 92-111.
- Navahandi, A. and A.R. Malekzadeh, 1997. Leadership style in strategy and organization and integral approach performance. *J. Manage. Stud.*, 3: 405-425.
- Nicolae, S. and A.M. Neagu, 2009. Human resource management and entrepreneurship education in a changing world. *Lex ET Sci. Int. J.*, 16: 322-342.
- Pearce, J.A. and B.R. Richard, 2008. *Strategic Management*. Salemba Four Publisher, Jakarta, Indonesia.
- Peltier, J.W., T. Boyt and J.A. Schibrowsky, 1999. Obstetrical care and patient loyalty. *Marketing Health Serv.*, 19: 5-14.

- Robbins, S.P. and T.A. Judge, 2009. *Organizational Behavior*. 12th Edn., Salemba Four Publisher, Jakarta, Indonesia.
- Scott-Ladd, B., A. Travaglione and V. Marshall, 2006. Causal inferences between participation in decision making, Task attributes, work effort, Rewards, job satisfaction and commitment. *Leadership Org. Dev. J.*, 27: 399-414.
- Sumodinoto, S., 1996. A study on factors that influence the performance of village Midwives. National Institute of Health Research and Development, Ministry of Health of Indonesia.
- Suryana, 2003. *Entrepreneurship Practical Guide, Tips and Process to Success*. Salemba Four, Jakarta, Indonesia.
- Umar, H., 2003. *Methods of Applied Accounting Research*. 1st Edn., Indonesian Ghalia, Jakarta, Indonesia.
- Van Dam, K., M. Schipper and P. Runhaar, 2010. Developing a competency-based framework for teachers' entrepreneurial behaviour. *Teach. Teacher Educ.*, 26: 965-971.
- Werdiningsih, 2014. Independent practice midwife should totality. Results Interview with the Chairman of the Indonesian Midwives Association Banyuwangi.
- Zahra, S.A. and J.G. Covin, 1995. Contextual influences on the corporate entrepreneurship-performance relationship: A longitudinal analysis. *J. Bus. Venturing*, 10: 43-58.
- Zimmerer, T. and N.M. Scarborough, 2005. *Essentials of Entrepreneurship and Small Business Management*. 4th Edn., Pearson Education, Inc., Upper Saddle River, New Jersey, ISBN-13: 9780131918566, Pages: 578.