

On-Line Data Acquisition Using Virtual Instrumentation and Sensor-less Speed Estimation of Three Phase Induction Motor-Neuro-Fuzzy Approach

S. Vijayachitra and A. Tamilarasi

Department of Electronics and Instrumentation Engineering,
 College of Kongu Engineering, Anna University, Perundurai-638052, India

Abstract: This study presents online data acquisition of 3 phase voltages (R,Y and B) of induction motor through Virtual Instrumentation (VI) with Lab VIEW 8.2 software package by interfacing with DAQ NI USB 6008 card and sensor-less speed measurement has been made by intelligent combination of Neural Networks and Fuzzy logic called as Adaptive Neuro-Fuzzy Inference System (ANFIS), i.e., Neuro-Fuzzy approach, which has been developed by MATLAB 7.5. The resulting conceptual neural fuzzy model contains the robustness of fuzzy systems, the learning ability of neural networks and can adapt to various situations in real time.

Key words: Induction motor, virtual instrumentation, data acquisition, sensor-less speed estimation, neuro-fuzzy technique

INTRODUCTION

The fuzzy modeling based technology is used to describe a complex non linear system based on the nature of human thinking. Fuzzy logic possesses non-linear mapping capabilities, do not require an analytical model and can deal with uncertainties in the system's parameters. Next, Neural network is an information processing paradigm that is inspired by biological nervous systems, such as the brain. The main advantage of neural network (Jin, 2003) is its learning capability of the system in on-line and off-line. In order to utilize the individual advantages of fuzzy logic and neural networks, fuzzy logic is implemented on neural networks, which is termed as Neuro-Fuzzy logic (Jang and Sun, 1995).

Three phase induction motors are the most common motors used in industrial motion control systems, as well as in main powered home appliances. Simple and rugged design, low-cost, reliability, self-starting capability, low maintenance and direct connection to an AC power source are the main advantages of three phase induction motors. It is substantially a constant speed motor with a shunt characteristic. Table 1 shows the specification of the three phase induction motor under test. Although, 3 phase induction motors are easier to design than DC motors, the speed and the torque control in various types of 3 phase induction motors require a greater understanding of the design and the characteristics of

Table 1: Specification of the three phase induction motor (under test)

Specifications	Three phase induction motor
Frame size	112 M
Rated power (HP kW ⁻¹)	5/3.7
Rated speed (rpm)	1470
Rated volatge (V)	415
Rated current (A)	7.9
Frequency (HZ)	50
No. Of poles	4

these motors (Bose, 2005). Various methods including direct torque control, vector control etc. have been attempted and failed in the proper speed estimation of three phase induction motors due to some limitations (Bose, 2005). In this study, speed of induction motor with sensor-less condition is successfully determined over wide range with appreciable accuracy using Intelligent Neuro-fuzzy model.

LabVIEW software contains a comprehensive set of tools for acquiring, analyzing, displaying and storing data in which a user interface or front panel can be built with controls and indicators (Eren and Rasan, 1998). After building the front panel, code is created using VIs and structures to control the front panel objects.

To build the Neuro-fuzzy model (Takagi and Sugeno, 1985), the parameters of the induction motor have been acquired using Lab VIEW (version 8.2) Software interfacing with DAQ NI USB 6008 card in real time and which can be used as training data for our proposed model to determine the sensor-less speed of the induction motor.

ON-LINE ACQUISITION OF I-O DATA USING VIRTUAL INSTRUMENTATION

For the purpose of sensor-less speed estimation of 3 phase induction motor, the real time acquisition of the 3 phase currents (i_a , i_b , and i_c) and the corresponding speed of induction motor under various load conditions has been performed as a primary step by using DAQ NI USB 6008 card and those 3 phase currents have been converted into 3 phase voltages with the help of Current to Voltage Converters (I-V). The second step is to create a Lab VIEW program to retrieve the sampled signals of induction motor (three phase currents and speed) from the data acquisition card.

Finally, the sampled data from the output of the Lab VIEW program is exported to excel spread sheet as training data for Neuro-Fuzzy Model to estimate the speed of the induction motor. Since, the data are stored in columns, further computation of the data is possible. The speed of the motor is stored as a value of time period and

duty cycle. These details have to be further modified and converted into speed for the use in MATLAB programming.

The details of NI USB 6008 are listed as follows:

- Eight analog inputs (12-bit, 10 kS/s).
- Two analog outputs (12-bit, 150 S/s); 12 digital I/O; 32-bit counter.
- Bus-powered for high mobility; built-in signal connectivity.
- OEM version available.
- Input Range: (+1-+20) V.
- Output Range: 0-5 V.
- Compatible with Lab VIEW, Lab Windows/CVI and Measurement Studio for Visual Studio .NET.
- NI-DAQ mx driver software and NI Lab VIEW Signal Express LE interactive data-logging software.

Signal analysis in Lab VIEW using DAQ assistant is shown in Fig. 1.

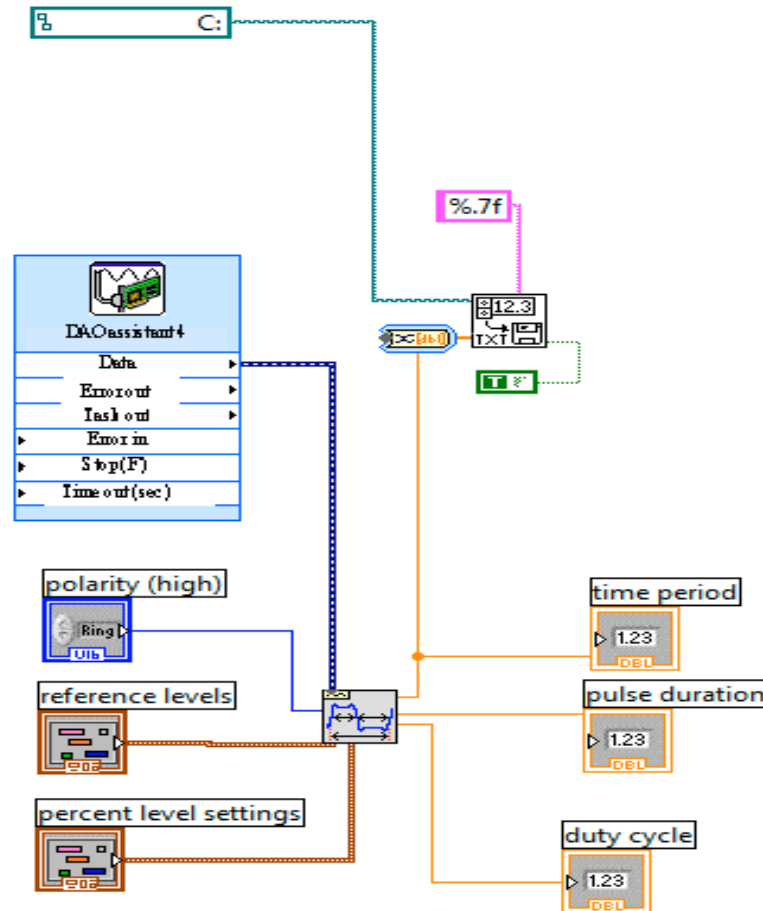

Fig. 1 : Pulse measurement and signal analysis in lab VIEW 8.2 using DAQ assistant

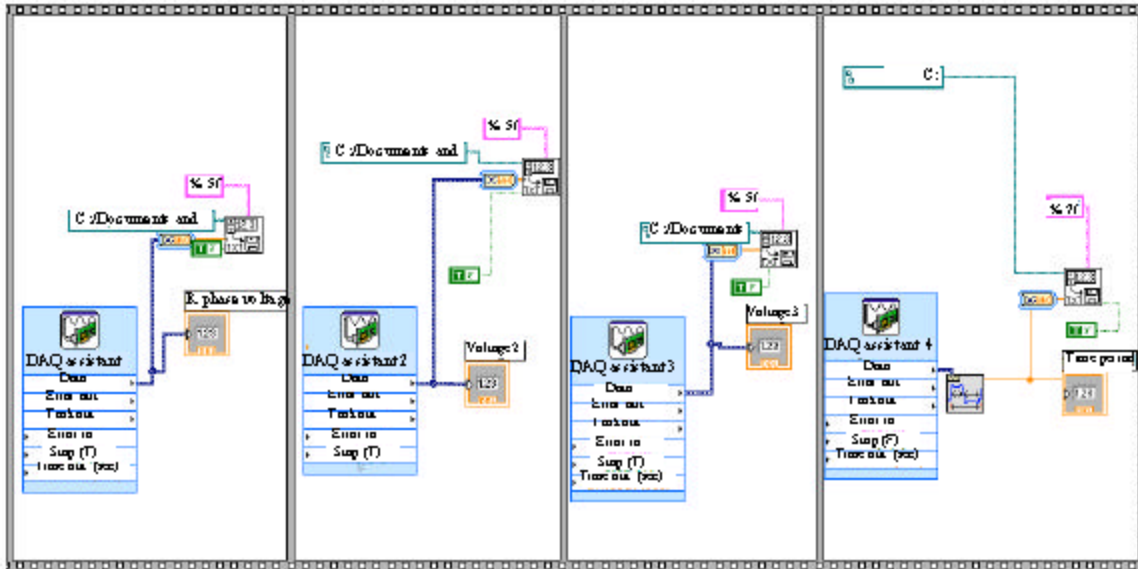

Fig. 2: Front panel view of data acquisition

The pulse measurement block in Fig 1 provides the facility to analyze the duty cycle, pulse duration and the time period of the signal. For the accurate measurement of the speed of the motor, the duty cycle along with the pulse duration is used in determining the speed.

The front panel of the data acquisition using DAQ 6008 is shown in Fig. 2.

The 3 phase currents in the 3 induction motor that is under test have to be analyzed using voltage to current converter. The maximum current that can be allowed to flow through the data acquisition card is 500 mA and the voltage level generally accepted by DAQ 6008 is -10 to 10 V DC. The maximum sampling rate of the DAQ 6008 is 8000 samples per sec. When all the eight channels are used, the sampling is evenly divided between the channels allowing a maximum of 1000 samples per channel.

For various loads, current and speed in rpm of the induction motor are measured. The sampled data of all these measurements are loaded as training/ testing input to the proposed neuro-fuzzy network, which are represented as mat files.

The 3 phase currents in the 3 phase have analysed using 3 different Current to Voltage converters. The voltage level generally accepted by DAQ 6008 is -10-10 volt DC. R, Y and B phase voltages and speed (I-O data) obtained using DAQ 6008 are listed in Table 2 and which are used to develop the Neuro-Fuzzy Model.

Table 2: I-O data acquired by DAQ 6008

R (volts)	Y (volts)	B (volts)	Time /rev(sec)	Speed rpm
2.2170	1.1836	1.5340	0.0425	1411.193
1.8406	1.2956	0.5066	0.0417	1437.390
2.8986	1.0972	1.5594	0.0422	1421.413
2.156	0.5224	0.8219	0.0415	1445.180
2.1966	1.8602	1.9714	0.0414	1448.544
1.2098	0.2578	0.4252	0.0420	1427.120
2.1560	1.5092	0.5320	0.0417	1437.848
2.0030	1.4685	1.7069	0.0411	1456.674
2.2780	1.5753	0.6846	0.0429	1395.358
1.1691	0.2070	0.3743	0.0421	1424.599
1.7388	1.0819	1.3865	0.041	1457.301
2.6951	1.1328	1.2797	0.0416	1441.226
...
1.3523	0.4359	0.6388	0.0421	1424.839
2.3594	1.9772	0.9898	0.0413	1449.492
2.0644	1.5499	1.8646	0.0430	1395.342
2.2577	0.5478	0.6032	0.0421	1424.454
1.8711	0.4155	0.5117	0.0410	1463.300
2.0847	1.5499	1.8747	0.0414	1448.309
1.9220	0.7411	0.8168	0.0420	1427.47
1.4235	0.6495	0.4761	0.0420	1428.367
2.7460	0.9191	1.2441	0.0413	1449.345

NEURO-FUZZY MODELING FOR SENSOR-LESS SPEED ESTIMATION OF THE INDUCTION MOTOR

Block diagram: The overall setup of the sensor-less speed measurement of three phase induction motor using Neuro-Fuzzy model is shown in Fig 3.

MATLAB software (version 7.5) is used to develop the Neuro-Fuzzy Model for speed estimation of three phase induction motor and for which on-line

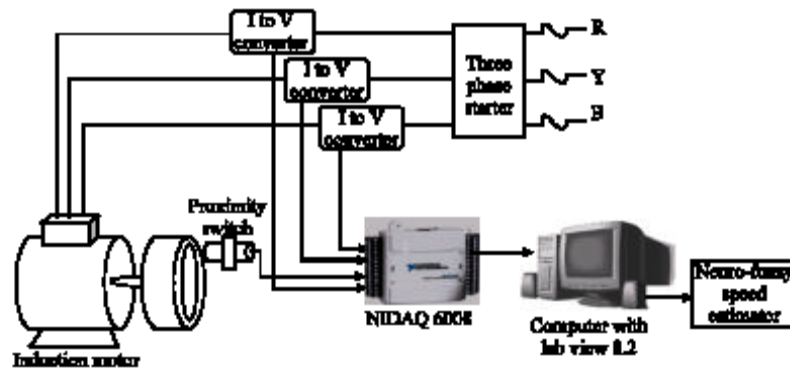

Fig 3: Online data acquisition of I-O and neuro-fuzzy based sensor-less speed estimation of 3 Φ Induction motor

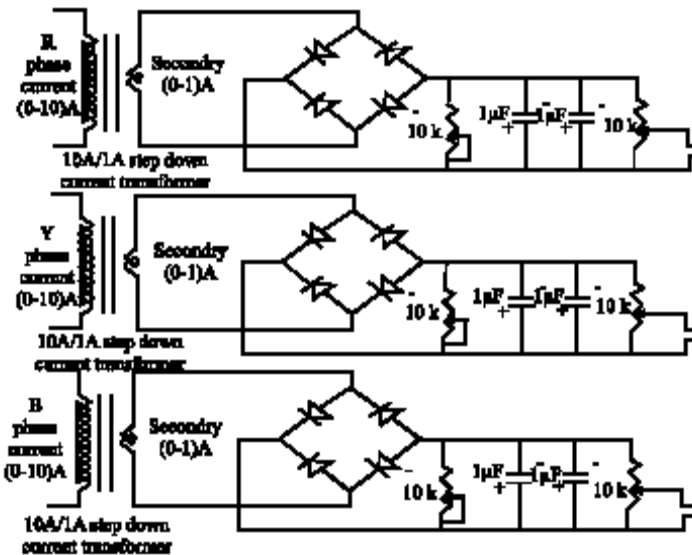

Fig 4: Three current to voltage converters used

I-O data acquired from induction motor using NI DAQ 6008 can be supplied.

The three phase voltages (R, Y and B) are considered as input parameters and Speed (rpm) is the output parameter of the Neuro-Fuzzy Model. Figure 4 shows the three Current to Voltage converters used for converting R phase current into R-voltage, Y phase current into Y-voltage and B phase current into B-voltage.

The proposed Neuro-Fuzzy Model to estimate the sensor-less speed of the induction motor is depicted in Fig 5.

Architecture: In an adaptive network, there are almost no constraints on the node functions except piecewise differentiability. Structurally, adaptive network should be of feed forward type. The proposed network architecture is referred to as ANFIS, which is a class of adaptive

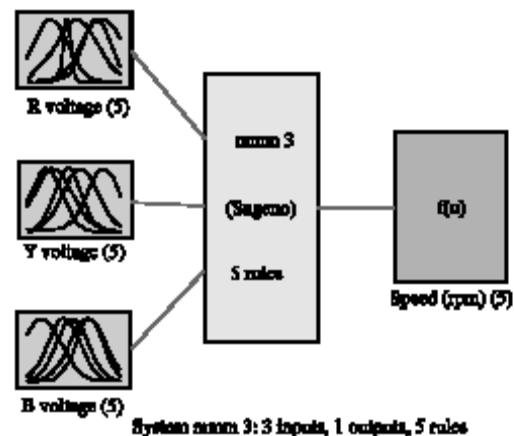

Fig 5: Neuro-fuzzy model of the process

networks and is functionally equivalent to fuzzy inference systems (Jang, 1993). ANFIS stands for adaptive network

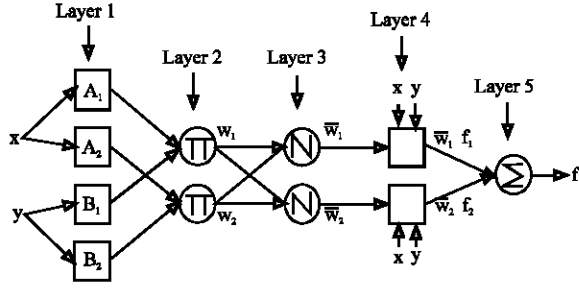

Fig. 6: ANFIS architecture

based fuzzy inference system or semantically equivalently Adaptive Neuro-Fuzzy Inference System. ANFIS implements Takagi-Sugeno fuzzy rules in a 5 layer MLP network. Back Propagation is used to modify the initially chosen membership functions and least mean square algorithm determines the co-efficients of linear output functions.

For a fuzzy inference system with two inputs x and y and one output z , a common rule set with 2 fuzzy if-then rules is as follows:

Rule 1: IF x is A_1 and y is B_1 , then

$$f_1 = p_1 x + q_1 y + r_1 \quad (1)$$

Rule 2: IF x is A_2 and y is B_2 , then

$$f_2 = p_2 x + q_2 y + r_2 \quad (2)$$

General architecture of a Neuro-Fuzzy model is illustrated in Fig. 6.

The above ANFIS Architecture is 5 layered architecture.

Layer 1: It is composed on n -number of fuzzy membership functions and every node i in this layer is an adaptive node with a node function

$$O_{1,i} = \mu_{A_i}(x), \text{ for } i = 1, 2 \text{ or} \quad (3)$$

$$O_{1,i} = \mu_{B_{i-2}}(y), \text{ for } i = 3, 4 \quad (4)$$

where, x (or y) is the input to node i and A_i (or B_{i-2}) is a linguistic label associated with this node. $O_{1,i}$ is the membership grade of a fuzzy set A ($=A_1, A_2, B_1$ or B_2) and it specifies the degree to which the given input x (or y) satisfies the quantifies A . Usually, we choose $\mu_{A_i}(x)$ to be bell shaped with maximum equal to 1 and minimum equal to 0, such as:

$$\mu_{A_i} = \frac{1}{1 + \left[\left(\frac{x - c_i}{a_i} \right)^2 \right]^{b_i}} \quad (5)$$

$$\mu_{A_i}(x) = \exp \left\{ - \left(\frac{x - c_i}{a_i} \right)^2 \right\} \quad (6)$$

where, $\{a_i, b_i, c_i\}$ is the parameter set. As the values of these parameters change, the bell shaped functions vary accordingly, thus exhibiting various forms of membership functions on linguistic label A_i . Parameters in this layer are referred to as premise parameters.

Layer 2: In Layer-2, each node calculates the firing strength of each decision rule via multiplication and every node in this layer is a fixed node labeled Π whose output is the product of all the incoming signals.

$$O_{2,i} = \omega_i = \mu_{A_i}(x) \cdot \mu_{B_i}(y) \text{ for } i=1,2 \quad (7)$$

Layer 3: It normalizes the conjunctives membership functions to rescale the inputs and every node in this layer is a fixed node labeled N , the i th node calculates the ratio of the i th rule's firing strength to the sum of all rule's firing strengths.

$$O_{3,i} = \bar{\omega}_i = \frac{\omega_i}{\omega_1 + \omega_2} \quad (8)$$

For convenience, outputs of this layer are called normalized firing strengths.

Layer 4: Every node i in this layer is an adaptive node with a node function

$$O_{4,i} = \bar{\omega}_i f_i = \bar{\omega}_i (p_i x + q_i y + r_i) \quad (9)$$

where, $\bar{\omega}_i$ is a normalized firing strength from layer 3 and $\{p_i, q_i, r_i\}$ is the parameter set of this node. Parameters in this layer are referred to as consequent parameters.

Layer 5: The single node in this layer is a fixed node labeled Σ , which computes the overall output as the summation of all incoming signals, which is of real (quantitatively) number.

$$\begin{aligned} \text{Overall output} &= O_{5,i} = \\ &= \sum_i \bar{\omega}_i f_i \\ &= \frac{\sum_i \bar{\omega}_i f_i}{\sum_i \bar{\omega}_i} \end{aligned} \quad (10)$$

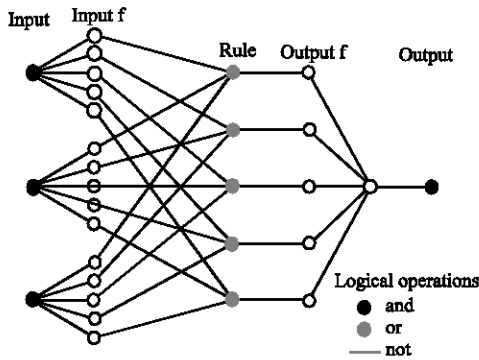

Fig. 7: Five-layer architecture of the neuro-fuzzy model

For our proposed work, an adaptive network, which is functionally equivalent to type-3 fuzzy inference system was developed. The input fuzzy membership function parameters and output consequent parameters are learned by the role of Back-Propagation Neural network.

Figure 7 shows the Five-layered architecture of the Neuro-Fuzzy Model of the speed estimation process.

Membership functions: A membership function is a curve, which shows the mapping of every point in the input space to a membership value between 0 and 1. The parameters associated with the membership functions changes through the learning process provided by the neural networks. For membership function parameter estimation, the combination of least squares estimation and Back propagation algorithm is used. The adjusted Membership functional diagrams of inputs of the process are shown in Fig. 8 (a-c).

Rules developed: The rules developed (Lin, 1992) to estimate the speed by Neuro-Fuzzy model are listed as follows:

- If (R-voltage is in 1 mf1) and (Y-voltage is in 2 mf1) and (B-voltage is in 3 mf1) then (Speed (rpm) is out 1 mf1) (1).
- If (R-voltage is in 1 mf2) and (Y-voltage is in 2 mf2) and (B-voltage is in 3 mf2) then (Speed (rpm) is out 1 mf2) (1).
- If (R-voltage is in 1 mf3) and (Y-voltage is in 2 mf3) and (B-voltage is in 3 mf3) then (Speed (rpm) is out 1 mf3) (1).
- If (R-voltage is in 1 mf4) and (Y-voltage is in 2 mf4) and (B-voltage is in 3 mf4) then (Speed (rpm) is out 1 mf4) (1).
- If (R-voltage is in 1 mf5) and (Y-voltage is in 2 mf5) and (B-voltage is in 3 mf5) then (Speed (rpm) is out 1 mf5) (1).

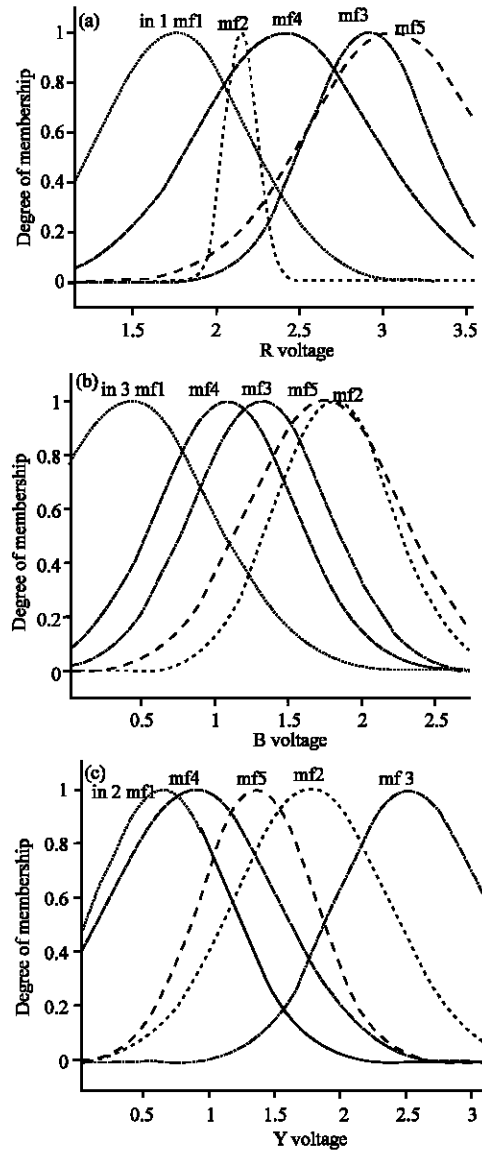

Fig. 8: Membership functional diagrams of three inputs of the process

The above rule base contains only dominant rules by eliminating the redundant rules and due to less number of rules the rule firing is simple and which also reduce the computational time.

The estimated output speed through the Neuro-Fuzzy Model is listed in Table 3 shows the comparison between the observed speed (rpm) and estimated speed (rpm) by Neuro-Fuzzy model and Statistical model (developed by MATLAB software).

Validation: Figure 9 shows the closeness between the original observed output speed and the Neuro-Fuzzy Speed and Fig. 10 shows the closeness between the

Table 3: Comparison performance of Speed estimation methods

Observed speed (rpm)	Neuro-fuzzy speed (rpm)	Statistical speed (rpm)
1411.194	1412.01	1441.94
1437.391	1438.11	1439.39
1421.414	1421.00	1451.44
1445.181	1444.98	1461.58
1448.544	1447.57	1441.54
1427.121	1428.02	1437.62
...
1424.840	1424.84	1424.02
1449.492	1449.50	1452.42
1395.342	1395.43	1396.98
1424.454	1424.50	1464.45
...
1410.765	1410.76	1410.02
1434.325	1435.03	1424.65
1418.513	1417.95	1419.55
1402.590	1402.59	1410.56
1423.792	1424.79	1423.88

Table 4: Validation of different models

Name of the model	Performance index (PI)	SD(%)
Neuro-fuzzy model	0.606	2.74
Statistical model	3.215	5.45

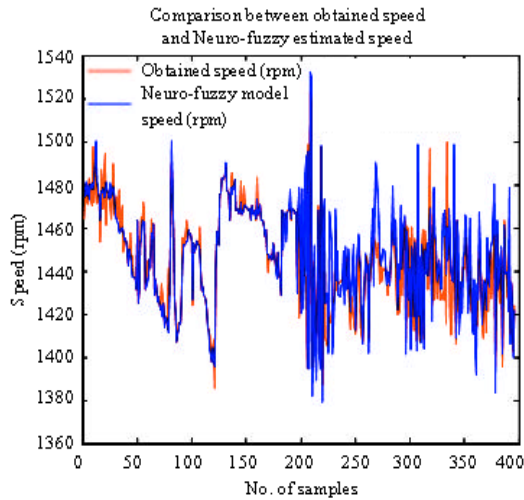

Fig. 9: Plot of observed and Neuro-Fuzzy estimated speed

original observed output speed and statistically obtained Speed (using linear regression method).

The performance of the Neuro-fuzzy modeling for speed estimation (Tamia and Hori, 1993) is assessed by evaluating the scatter between the above 2 through Performance Index (PI) and Percentage Standard Deviation (SD%). The performance index has been defined as the root mean square of the output errors (the differences between the practically observed data of the original system and the result data of the system model). Table 4 shows the validation of the fuzzy qualitative model through PI and SD (%).

$$PI = \sqrt{\frac{\sum_{i=1}^n (X_{1i} - X_{2i})^2}{n}} \quad (11)$$

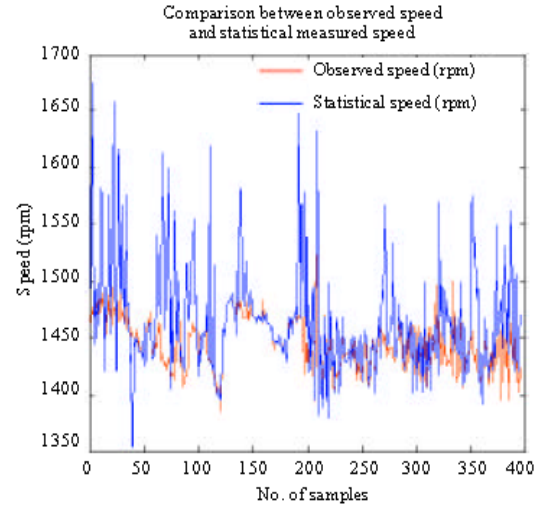

Fig. 10: Plot of observed and statistically estimated speed

$$SD (\%) = \sqrt{\frac{1}{n} \sum_{i=1}^n \left(\frac{X_{1i} - X_{2i}}{X_{2i}} \right)^2} \times 100 \quad (12)$$

where:

x_1 = Predicted model output.

x_2 = Observed data.

n = Number of output values.

CONCLUSION

To increase the performance of sensor-less speed estimation of three phase induction motor, a new estimation procedure using the combination of both Back Propagation Neural Network and Fuzzy Logic called Neuro-Fuzzy Model was introduced. The on-line I-O data from the induction motor were acquired by using NI DAQ 6008 properly and used to develop the proposed model. A 5 layered Adaptive Neuro-Fuzzy Inference System (ANFIS) network was developed for sensor-less speed estimation with respect to the acquired on-line data. The developed model was also validated through Performance Index and Percentage standard deviation. From the comparison purpose, a statistical model was also developed by using linear regression method. From the performance of different speed estimation models and their validation, the Neuro-Fuzzy model has the ability to estimate the sensor-less speed (rpm) output accurately.

REFERENCES

- Bose, B.K., 2005. Modern power electronics and AC drives. Prentice-Hall of India Pvt. Ltd., New Delhi, pp: 388-399, 629-657.
- Eren, H. and T. Rasan, 1998. A virtual instrumentation for monitoring induction machines. IEEE Proc. Power Electronic Drives and Energy Syst. Ind. Growth, 1: 141-146.
- Jang, J.S.R. and C.T. Sun, 1995. Neuro-Fuzzy Modeling and Control. Proc. IEEE, 83: 378-406.
- Jang, J.S. R., 1993. ANFIS: Adaptive-network-based fuzzy inference system. IEEE Trans. Syst., 23: 665-685.
- Jin, Y., 2003. Advanced Fuzzy Systems Design and Soft Computing, Springer.
- Lin, C.T., 1992. A neural fuzzy control system with structure and parameter learning. Fuzzy Sets and Syst., 70: 183-212.
- Tamia, H. and Y. Hori, 1993. Speed sensor less field orientation control of the induction machine. IEEE. Trans. Ind. Appl., 29: 175-180.
- Takagi, T. and M. Sugeno, 1985. Fuzzy identification of systems and its applications to modeling and control. IEEE Trans. Syst. Man and Cybernetics, 1 (1): 116-132.