

## Optimization of the Damping Element of Axial Vibrations of the Drilling String by Computer Simulation

<sup>1</sup>K. Syzrantseva, <sup>1</sup>V. Arishin and <sup>2</sup>M. Dvoynikov

<sup>1</sup>Industrial University of Tyumen, Volodarskogo-Street, 38, 625000 Tyumen, Russia

<sup>2</sup>National Mineral Resources University, 21st Line, 2 St. Petersburg, 199106 Petersburg, Russia

---

**Abstract:** During well-drilling in conditions when bedding of solid rock is at shallow depth (from the first meters) there are significant vibrations of drilling string and connected equipment. In such situation when length of a drilling string is small and axial load on drilling bit is minimum, the effective device is necessary for compensation of axial pushes and vibrations. At the same time the geometrical shape of the damping element has to ensure the stability at significant excess of limit load and reliability. Warranty of shape retention at drilling depth increase (and respectively, increase of drilling string length and weight) will allow to avoid the additional round-trip operations for extraction of the damping device. The study considers the main stages and features of computer simulation of damping elements operating at shallow depth of solid rock bedding by finite element method and also the subsequent optimization of its design which has allowed to increase a compliance from 0.8-15 mm and at the same time to provide sufficient strength reliability. The calculation model of the analysis and also boundary conditions for modeling of multicontact interaction of slot surfaces of damping elements is described in detail. The computer simulation allows to perform optimization of model at a designing stage. It considerably reduces costs for creation of new model of a design as excludes need of production of several natural samples and their bench testing for durability verification.

**Key words:** Well-boring, axial vibrations, damping element, compliance, strength reliability, finite element method, optimization

---

### INTRODUCTION

The result of high-quality construction of a well is its durability and reliability in operational conditions. It is based on application of modern both the above-ground and downhole equipment with use of the cumulative technological experience of drilling operations executing.

As experience of the boring enterprises testifies, the application of a rotary method of drilling using the modern types of the screw down-hole motors as the drive of rock cutting tool is priority in this direction (Dvoynikov and Blinoz, 2016)

The most essential advantage: the increased energy characteristics allowing to drill wells of various depth with different types of a profile with broad ranges of type and properties of drilling fluids and parameters of the drilling mode and also using different designs and standard sizes of the rock cutting tool.

In the drilling process by screw down-hole motor (Cao and Wu, 2010) there are various swings and vibrations which can lead to damages of drilling string elements and also breakage of the bottom hole assembly. The main forms of vibrations of drilling string are.

The axial vibrations, caused by drilling bit operation and a pulsation of drilling fluids fluid in working chambers of screw down-hole motor (Syzrantseva and Syzrantseva, 2016) the cross beats of screw down-hole motor body caused by design features of the hydraulic mechanism. Axial and torque vibrations (taking into account axial load to drilling bit and amount of deflection in the place of the angle controller of power section and spindle) lead as a rule to loss of drilling string stability and emergencies in a well.

For the purpose of increase of drilling string reliability in practice of drilling it is accepted to mount the damping elements providing decrease an axial vibrations of bottom hole assembly. Design of a damping element provides the body with the rigid-elastic mechanism (spring) inside which is the basic element for vibrations absorbing. Also damping element may contain the hydraulic camera providing vibration lowering by compressibility of fluid.

One variant of damping element design is the mechanical device for decrease of longitudinal vibrations of drilling bit described in research. However, as practice shows, damping element of this type have restrictions of the free axial stroke and low strength characteristic.

This study considers the features of computer simulation of damping elements operating and optimization of their designs, for the purpose of ensuring its working capacity at different regimes of bottom hole assembly operation (Syzrantsev and Syzrantseva, 2016).

**MATERIALS AND METHODS**

**Computer simulation:** The geometrical shape of initial variant of damping element was the cylinder with several slots, perpendicular rotation axes (two slots in one plane), showed on Fig. 1a. Slots are made in such way that each two couples of neighboring slots are turned from each other on 90°. Material of the damping element: steel 65G (yield strength is 1220 MPas, tensile strength is 1470 MPas). The axial loading leads to the “folding” of damping element design allowing to compensate axial pushes in the drilling process. Hertz equation used for contact pressure estimation allows to get only stress value in centre of contact area and does not allow to analyze the multicontact interaction between surfaces of slots of damping element. Therefore for this task decision it is advisably to use numerical method.

For today development of numerical methods allows to carry out modeling of various physical processes. The Finite Element Method (FEM) (Burkhart *et al.*, 2013) is widely used in various industries including oil and gas sector of industry (Syzrantsev and Syzrantseva, 2016; Bae *et al.*, 2016; Makhutov *et al.*, 2009; Dhatt *et al.*, 2012). However, the calculation model for simulation has to be as close as possible to loading conditions of researched equipment at its operation. Program complex ANSYS is characterized by the most ample opportunities for the solution of spatial contact tasks and it is successfully applied for durability and reliability estimation of drilling (Oshibkov *et al.*, 2015a; Syzrantseva, 2016) and oil equipment (Syzrantsev and Syzrantseva, 2016).

We will consider the main stages of the Finite Element Analysis of damping element. In the analysis process the five stages of modeling and calculation are realized. At the first stage the creation of geometrical model is carried out. The geometrical model was designed by CAD-system and imported to ANSYS, it allows to simplify considerably the process of model creation. Because of symmetry of a damping element about two planes, only ¼ part of sample was subjected to the analysis (Fig. 1). To check the accuracy of the geometrical model created in CAD-system, it is possible by using the coordinate measuring machines (Shchurov, 2011). At the second stage imported from CAD-system geometrical model is subjected to meshing by finish elements in software ANSYS. As the geometrical model of the damping element has an irregular spatial shape, the finite element model is meshed by three-dimensional structural element

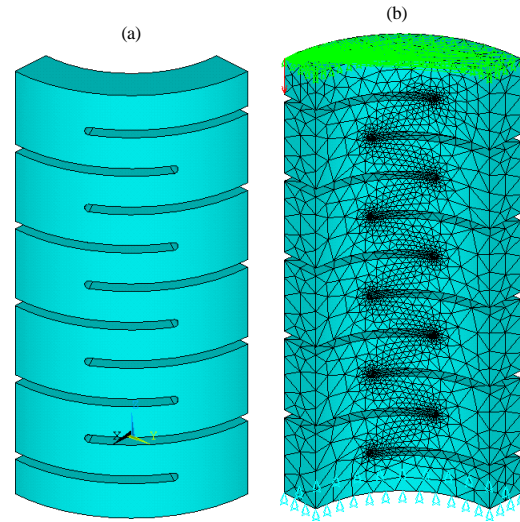

Fig. 1: The calculation model of the computer analysis: a) geometrical model and b) finite element model)

Solid92 (Oshibkov *et al.*, 2015b). For contact task description we created 10 symmetric contact pairs (Solovyov and Cherniavsky, 2013) defined by elements CONTA174-TARGE170 modeling deformable contact taking into account friction, as recommended in study (Ananth and Ramesh, 2012).

At the third stage boundary condition are defined. Bottom surface of damping element has zero displacements on all degrees of freedom. Symmetry is applied on face surfaces of model. Nodes attached to upper surface of damping element are coupled and subjected by axial compressing force  $F_a$  (Fig. 1b).

At the fourth stage for this task decision we used SRARSE SOLVER. As analyzed model was optimized in accordance with restrictions and features of Finite Element Method, there was not required to change the options for solving non-linear contact task. At the fifth stage the analysis of results needed for estimation of serviceability criteria of damping element is carried out.

For check of calculation model adequacy it is necessary to estimate the finite element grid quality. The finite element grid quality estimation was realized similar to study (Oshibkov *et al.*, 2015a), in accordance with equation:

$$\nabla_1 \frac{ESOL-NOSL}{ESOL} \times 100\% = 8.72\%$$

Where:

ESOL = Element solutions

NSOL = Nodal solutions

The estimation has shown quite satisfactory results. Total displacements in damping element loaded by axial

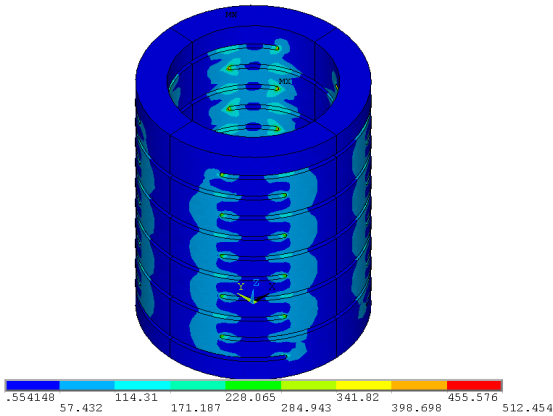

Fig. 2: Total displacements of initial variant of damping element

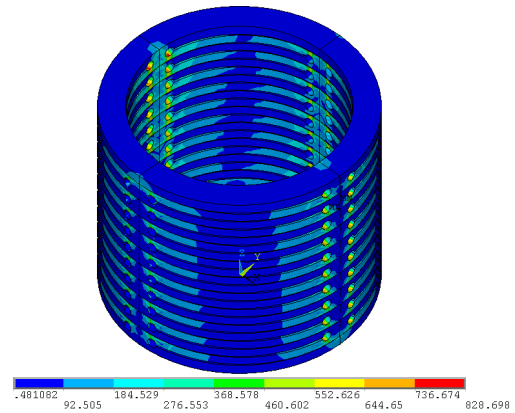

Fig. 4: Total displacements of optimized variant of damping element

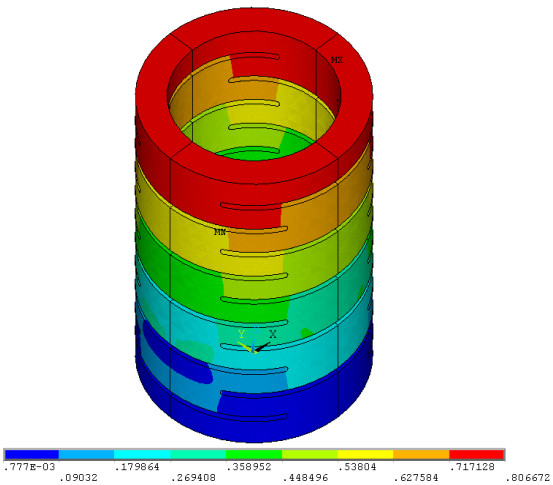

Fig. 3: Contours of von Mises stress of initial variant of damping element

force  $F_a = 30 \text{ kN}$  are presented on Fig. 2, maximum axial displacements of initial design of damping element were 0.8 mm. Contours of von Mises stress the most illustrative for damping element durability estimation are shown on Fig. 3. Maximum value is 512.4 MPas.

**Optimization of damping element design:** The design of damping element offered initially did not meet the set requirements as was characterized by an insufficient compliance for compensation of axial pushes. The computer modeling allows to perform optimization of model at a designing stage that considerably reduces costs for creation of new model of a design as excludes need of production of several natural samples and their bench testing.

Therefore, researchers have performed the optimization of the damping element geometrical shape so

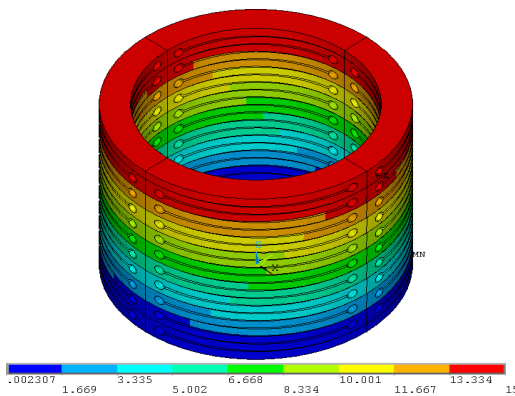

Fig. 5: Contours of von Mises stress of optimized variant of damping element

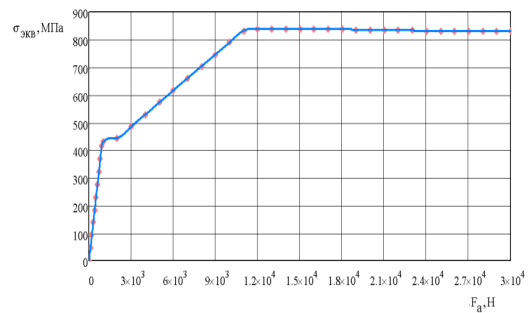

Fig. 6: Function of maximum von Mises stress depending on axial compressing force value (Results of computer simulation showed by labels and plotted function  $\sigma_{EQV}$  showed by solid curve)

that to increase the damping element compliance and at the same time not to allow to exceed the yield strength of material. In a design there were following changes:

thickness of a cylinder wall the and distance between slots decreased, the number of slots and their size increased and also holes in the slot edges for elimination of stress concentrators were added. The new shape of damping element has also been calculated on the loading much exceeding the operating load ( $F_a = 10$  kN). At excess of limit load there is “folding” of damping element design and the maximum value of von Mises stress decreases a little due to their redistribution from places of stress concentrators to places of contact between slot surfaces. The result of the stress-strain condition calculation of a final shape of damping element is given on Fig. 4-6. Under the maximum operating load ( $F_a = 30$  kN) the value of compression of damping element is 15 mm, the value of the maximum von Mises stress 828.7 MPas.

By results of additional computer simulation of an optimal model the function of maximum von Mises stress depending on axial compressing force value varied in interval from 0.1-30 kN was established with the help of regression analysis:

$$\sigma_{EQV} = f(F_a)$$

The curve of function (2) is presented on Fig. 6.

## CONCLUSION

The method of computer simulation of damping element described in paper allows to estimate the compliance value (the axial stroke) of a design and also its strength characteristics at a designing stage. By stage-by-stage change and modification of an initial design the comparative analysis of different variants of a design without production and test of natural samples is carried out that considerably reduces the price of optimization process (Lee *et al.*, 2014)

The offered method of simulation has allowed the authors to develop the new design of damping element which is characterized by the compliance increased almost by 20 times and at the same time sufficient strength reliability. The developed design of damping element will allow to increase efficiency of drilling of oil and gas wells, ensuring operational stability of the screw down-hole motor and rock cutting tool.

## REFERENCES

Ananth, M.P. and R. Ramesh, 2012. Analysis of sliding behaviour of non-conformal contacting surfaces subjected to shear traction. *Procedia Eng.*, 38: 2645-2656.

- Bae, J.H., H.S. Kwak, S. San and C. Kim, 2016. Design and CFD analysis of gerotor with multiple profiles (ellipse-involute-ellipse type and 3-ellipses type) using rotation and translation algorithm. *Proc. Inst. Mech.Eng. Part C J. Mech. Eng. Sci.*, 230: 804-823.
- Burkhart, T.A., D.M. Andrews and C.E. Dunning, 2013. Finite element modeling mesh quality, energy balance and validation methods: A review with recommendations associated with the modeling of bone tissue. *J. Biomech.*, 46: 1477-1488.
- Cao, H. and W.H. Wu, 2010. Simulation Study on Deep Hole Drilling Machine Hydraulic System Based on System Schematic Diagram. In: *Advanced Materials Research*, Dunwen, Z., H. Guo, X. Hongli, S. Chun and L. Chunjie *et al.*, (Eds.). Trans Tech Publications, Switzerland, pp: 144-147.
- Dhatt, G., E. Lefrancois and G. Touzot, 2012. *Finite Element Method*. John Wiley & Sons, Hoboken, New Jersey, USA.,.
- Dvoynikov, M.V., P.A. Blinov, 2016. Survey results of series-produced downhole drilling motors and technical solutions in motor design improvement. *Intl. J. Appl. Eng. Res.*, 10: 7034-7039.
- Lee, S.S., J. Moon, K.S. Park and K.W. Bae, 2014. Strength of footing with punching shear preventers. *Sci. World J.*, 2014: 1-15.
- Makhutov, N.A., M.M. Gadenin, O.F. Chernyavskii, A.O. Chernyavskii and S.V. Evropin, 2009. Low-cycle deformation of the structures in a nuclear power plant and methods for calculating them. *At. Energy*, 107: 173-179.
- Oshibkov, A.V., D.D. Vodorezov, K.V. Syzrantseva, S.A. Frolov and M.V. Dvoynikov *et al.*, 2015a. The stress-strain condition estimation of construction of multilateral well junction. *Oil Ind.*, 2015: 83-85.
- Oshibkov, A.V., D.D. Vodorezov, K.V. Syzrantseva, S.A. Frolov and M.V. Dvoynikov *et al.*, 2015b. Analysis of sidetracking characteristics influence on multilateral well construction reliability. *Oil Ind.*, 11: 121-123.
- Shchurov, I.A., 2011. Calculation of the virtual pitch thread diameter using the cloud of points from CMM. *Intl. J. Adv. Manuf. Technol.*, 53: 241-245.
- Solovyov, V. and A. Cherniavsky, 2013. Computational and experimental analysis of trawl winches barrels deformations. *Eng. Failure Anal.*, 28: 160-165.
- Syzrantsev, V. and K. Syzrantseva, 2016. Reliability estimation of machine parts with complicated geometry on a base of methods of nonparametric statistics. *J. Eng. Appl. Sci.*, 100: 204-209.
- Syzrantseva, K. and V. Syzrantsev, 2016. Load on multipair contact zones of operating parts of screw pumps and motors: A computer analysis. *Procedia Eng.*, 150: 768-774.