

Voltage Control of Buck Converter-Based Ant Colony Optimization for Self-Regulating Power Supplies

¹Wisam Najm AL-Din Abed, ²Omar A. Imran and ³Ali N. Jbarah

¹Department of Electronic Engineering,

²Department of Chemical Engineering, ³Department of Materials Engineering,
College of Engineering, University of Diyala, Diyala, Iraq

Abstract: The significance of self-regulating power suppliers is based on providing a constant output voltage even under any source disturbance. Dc-dc converter with LC filter (buck converter) can provide constant output voltages when use a proper closed loop control system. In this research a mathematical model of buck converter is designed and simulated using MATLAB Simulink toolbox. Lead compensator is designed plus Pulse Width Modulation (PWM) for controlling the output voltages. A new metaheuristic optimization technique called Ant Colony Optimization (ACO) technique is proposed for tuning the parameters of lead compensator. ACO optimally choose compensator parameters, gain, poles and zeros locations. The buck converter are tested under variation in input voltages above and below its nominal value to show the robustness of the compensator based ACO technique. The ACO strategy have many advantages like, fast convergence, simple implementation, lower algorithm parameters are required as well as required lower consecution time. The results show that the proposed approach has superior feature, including easy implementation, stable convergence characteristics and very good computational performances efficiency, also improving the transient and steady state behavior of the system.

Key words: Buck converter, ant colony optimization, lead compensator, self-regulating power suppliers, consecution, implementation, characteristics

INTRODUCTION

Switched mode dc-dc converters are one of the simplest power electronic circuits which transform one voltage level into another level by switching action. Now days these converters are employed in many areas like personal computers power supplies, DC motor drives, office equipment's, appliance control, telecommunication equipment's, automotive, aircraft, etc. The analysis, design, control and stabilization of switching mode converters are the key factors that need to be considered. Different control methods are used for control the output voltage of switch mode dc-dc converters. Also, simplicity and low-cost controller scheme is always needed for most industrial and high-performance applications. Every control scheme has some advantages and disadvantages due to each particular control method is considers suitable under specific conditions that may not proper other control methods (Biswal, 2011).

The term optimization is related with almost every engineering problems. The primary principle in optimization is to impose constraints that must be

satisfied during exploring as many options as possible in the search space. There are numerous optimization strategies. Recently bio-inspired (or nature inspired) optimization techniques are category of stochastic optimization search techniques that suitable for linear and nonlinear process. Hence, nature-based computing techniques are an attractive area of research. The nature-based computing applications include optimization, data analysis, data mining, computer vision and graphics, diagnosis and prediction, designing, intelligent control, traffic and transportation systems (Abed, 2014).

In recent years Swarm Intelligence (SI) is advanced optimization strategies that mimics the social behaviors of different animal swarms in nature. However, the populations have only simple behaviors and depend on interaction and cooperation. Now days, several swarm intelligence optimization algorithms have been proposed such as Particle Swarm Optimization (PSO), Ant Colony Optimization (ACO), Artificial Bee Colony (ABC) and Bacterial Foraging Optimization (BFO) (Saleh *et al.*, 2015).

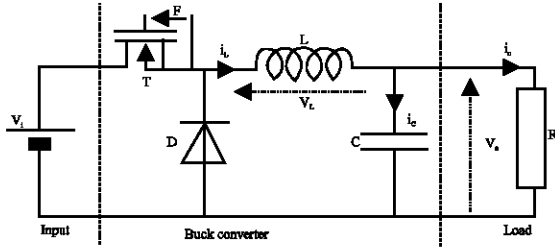

Fig. 1: Buck converter circuit

MATERIALS AND METHODS

Mathematical model of buck converter: The buck converter complete circuit is shown in Fig. 1. The buck converter have three operating modes as illustrated in Fig. 2. The three operating phases are:

- T state-on and D state-off
- T state-off and D state-on
- T and D state-off

Equation 1 represent the capacitor current while Eq. 2 represent the output voltage of buck converter (the voltage across the capacitor). Equation 3 determine the inductance voltage and it depend on the operating phases. F is logical operator that specifies the operating phase (Katsikis, 2012):

$$i_c(t) = i_L(t) - i_o(t) = C \frac{dv_o}{dt} \quad (1)$$

$$v_o = \frac{1}{C} \int i_c(t) dt = \frac{1}{C} \int (i_L(t) - i_o(t)) dt \quad (2)$$

$$v_L(t) = (v_i(t) - v_o(t)) * F - v_o(t) * \bar{F} * \text{sign}(i_L) \quad (3)$$

Ant Colony Optimization (ACO): Ant Colony Optimization (ACO) was proposed by Dorigo *et al.* It is a metaheuristic technique that mimics ant colonies natural behaviors (Shelokar *et al.*, 2004; Omar *et al.*, 2013). The ACO algorithms mimics the real ants behavior to find the shortest path between a food source and their nest. The ants communicate with other ants by pheromone trails and exchange information to specify the path that should be followed. The highest pheromone density path is the high probability path to choose (Shelokar *et al.*, 2004). The ACO algorithm flow chart is shown in Fig. 3 (Booba and Gopal, 2014; Oshaba *et al.*, 2015). The ACO algorithms steps are as follows:

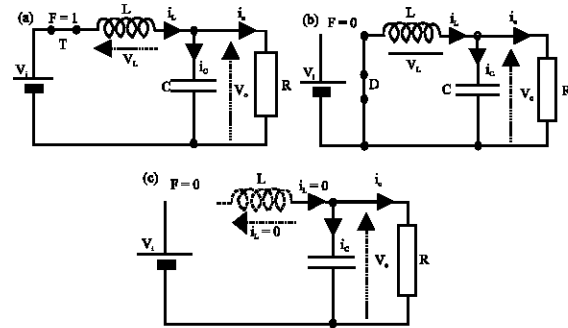

Fig. 2: Buck converter operating modes: a) T state-on and D state-off; b) T state-off and D state-on and c) T and D state-off

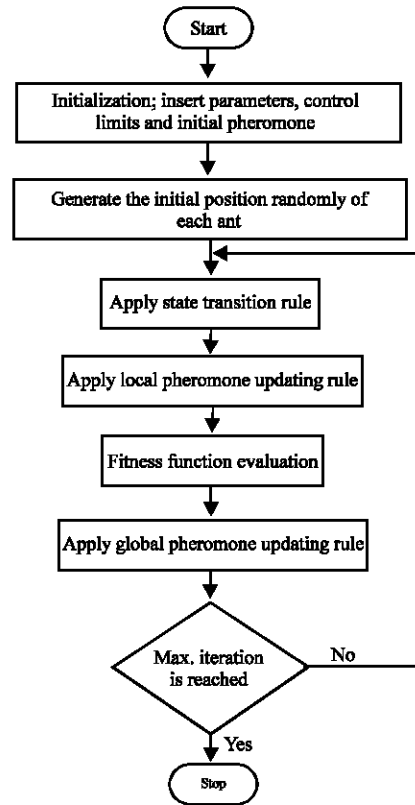

Fig. 3: Flow chart of ACO algorithm

The ACO algorithms:

Step 1: Parameters initialization (n, m, tmax, dmax, β, ρ, α, q_s and τ₀)

Where

- n: Nodes number
- m: Ants number
- tmax: Maximum iteration number
- dmax : Maximum distance of each ant's tour
- β: Parameter specifies the relative importance of pheromone against distance (β>0)
- ρ: Heuristically coefficient (0<ρ<1)
- α: Pheromone decay parameter (0<α<1)
- q_s: Parameter of the algorithm (0<q_s<1)

τ_0 : Initial pheromone level

The maximum distance for each ant's is calculated as:

$$d_{max} = \max \left[\sum_{i=1}^{n-1} d_i \right] \quad (4)$$

$$d_i = |r - \max(u)| \quad (5)$$

Where:

d_i : distance between two nodes

u : unvisited node

r : current node

Step 2: Generation random initial first position of each ant

Step 3: Transition rule

This step illustrates the probability for an ant k at node i to choose next node j . The chosen probability can be expressed as:

$$P_{ij}^k(t) = \frac{[\tau_{ij}(t)]^\alpha [\eta_{ij}(t)]^\beta}{\sum_{j \in T^k} [\tau_{ij}(t)]^\alpha [\eta_{ij}(t)]^\beta} ; i, j \in T^k \quad (6)$$

Where:

$\tau_{ij}(t)$: represent pheromone trail placed between node i and j by ant k

$\eta_{ij}(t)$: inverse of the distance

T^k : is the effectuated path by the ant k at a given time

Step 4: Updating local pheromone for each ant

Each ant initial pheromone is locally updated as shown:

$$\tau_{ij}(t+1) = (1-\rho)\tau_{ij}(t) + \rho\tau_c \quad (7)$$

Step 5: Calculation of cost or fitness function

Highest pheromone density route represents the shortest route with best objective function solution

Step 6: Updating global pheromone

The best tour is the highest pheromone density tour. Moreover, the pheromone in other paths is evaporated with time. The pheromone level is updated as in Eq. 8:

$$\tau_{ij}(t+1) = (1-\alpha)\tau_{ij}(t) + \alpha\Delta\tau_{ij}(t) \quad (8)$$

Step 7: Stopping criteria (maximum number of iteration is reached or the best solution is attained)

RESULTS AND DISCUSSION

The first step in analysis and designing the control system for the buck converter is to use the mathematical model of the buck converter which is more reality to the actual plant rather than linear transfer function model in the control design and studies. The simulation of buck converter is done using MATLAB/Simulink. The Simulink of the buck converter mathematical model is shown in Fig. 4.

The parameters values of buck converter used in the simulation are shown in Table 1. The block diagram of complete control system with implementation of ACO technique is shown in Fig. 5.

ACO strategy is used for tuning lead compensator for optimal parameters tuning. The ACO algorithm parameters used in this study are illustrated in Table 2.

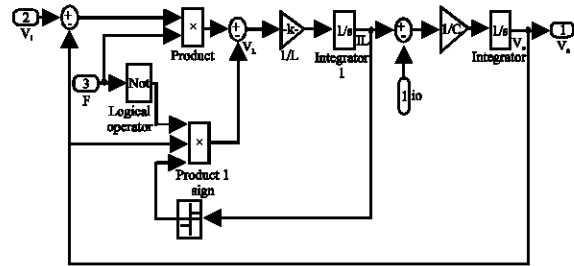

Fig. 4: Simulink of buck converter

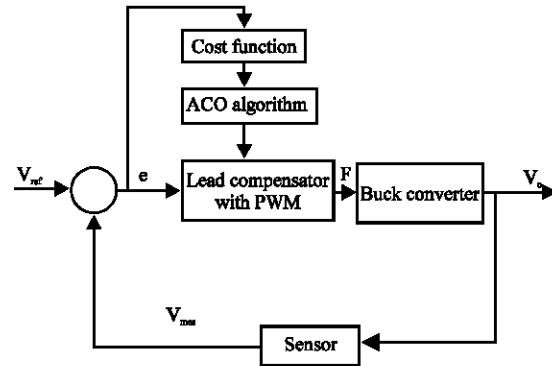

Fig. 5: Block diagram of proposed work

Table 1: Buck converter parameters

Parameters	Values
Input voltage	12 V
Switching frequency	50 kHz
Reference voltage	2.5 V
Load resistance R	3 Ω
Measurement resistance R1 = R2	10 kΩ
Capacitance	5 μF
Inductance	300 μH

Table 2: ACO algorithm parameters

Parameters	Values
Number of iteration	20
Number of ants	20
Nodes of number	1000
α	0.8
β	0.2
Evaporation rate	0.7

The lead compensator parameters obtained based ACO technique are compensator gain $K_c = 525.35$, pole location $P = -636.23$ and zero location $Z = -53.12$. The cost function plot of the ACO algorithm is shown in Fig. 6.

Figure 7-9 illustrate the buck converter measured voltage, output current and output voltage step response, respectively. To test the controller robustness base proposed technique, the input voltage of the buck converter is changed within $\pm 20\%$ of its nominal voltage. Figure 10 shows the comparison of the buck converter output voltage under different input voltage.

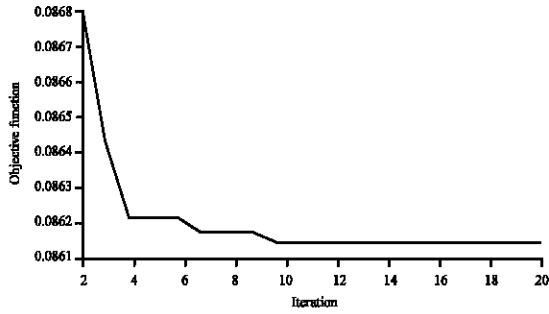

Fig. 6: Cost function plot

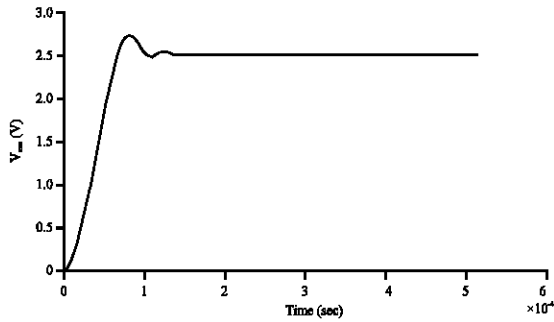

Fig. 7: Buck converter measured voltage

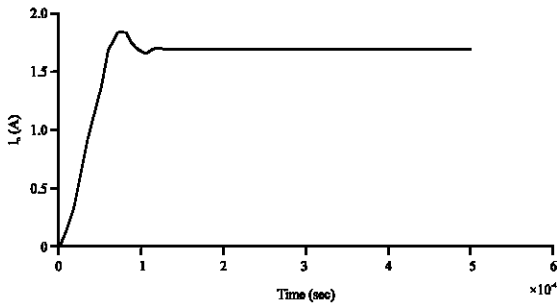

Fig. 8: Buck converter output current

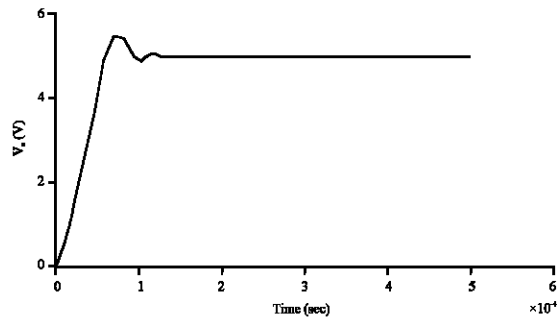

Fig. 9: Buck converter output voltage

The time specifications of the buck converter output voltages under different input voltages is shown in Table 3.

Fig. 10: Buck converter output voltage with $\pm 20\%$ change in input voltage

Table 3: Time specifications of the output voltages step response

Change in input voltages	Rise time (msec)	Peak time (msec)	Peak over shoot (%)	Settling time (msec)
20% below normal input voltage	8.700	9.55	2.0	12.2
10% below normal input voltage	7.300	8.55	3.0	11.4
Normal input voltage	6.370	7.60	4.2	10.8
10% above normal input voltage	5.690	7.24	6.0	10.4
20% above normal input voltage	5.186	7.23	7.2	10.3

From the obtained results, it is clearly that the proposed technique improves the compensator performance by appropriate controlling the buck converter output voltages under sudden variation in input voltages. All obtained time specifications are acceptable and within our objective criteria. The ACO proposed technique are work optimally for tuning lead compensator parameters. It posses a very good characteristics like, lower algorithm parameters, simple structure, fast convergence.

CONCLUSION

The buck converter can provide a constant output voltage even under input voltage variations. This ability makes the buck converter to use in self-regulating power supply. Proper closed loop control system lead to control the output voltage under sudden change in input voltage. Lead compensator is proposed as a controller that improves the transient and steady state plant behavior as well as improve the system stability. Optimal parameters tuning of lead compensator makes this controller robust. So, a new metaheuristic optimization technique called ACO is proposed for tuning the controller parameters. The robustness of the lead compensator is obvious from the results. It is clearly that the transient and steady state behavior are improved by reducing the rise time, peak time, percent over shoot and settling time even under

different changes in input voltages. The proposed technique improves the controller ability by optimal parameters tuning. The proposed technique has fast convergence ability, lower parameters of algorithm, simple structure and explore the search space effectively.

REFERENCES

- Abed, W.N.A., 2014. Compensators design of DC motors using bacterial foraging optimization technique. *J. Sci. Eng. Res.*, 1: 64-75.
- Biswal, M., 2011. Control techniques for DC-DC buck converter with improved performance. Master Thesis, National Institute of Technology, Rourkela, Rourkela, India.
- Booba, B. and T.V. Gopal, 2014. Comparison of ant colony optimization and particle swarm optimization in grid scheduling. *Asian J. Inf. Technol.*, 13: 561-565.
- Katsikis, V., 2012. MATLAB: A Fundamental Tool for Scientific Computing and Engineering Applications-Volume 1. InTech, Rijeka, Croatia, ISBN:978-953-51-0750-7,.
- Omar, M., M. Soliman, A.A. Ghany and F. Bendary, 2013. Ant colony optimization based PID for single area load frequency control. Proceedings of the 5th International Conference on Modelling, Identification and Control (ICMIC'13), August 3 - September 2, 2013, IEEE, At Cairo, Egypt, ISBN:978-0-9567157-3-9, pp: 119-123.
- Oshaba, A.S., E.S. Ali and S.A. Elazim, 2015. Ant colony optimization algorithm for speed control of SRM fed by photovoltaic system. *J. Electr. Eng.*, 15: 55-63.
- Saleh, A.H., K.A. Humood and W.N.A. Abed, 2015. Design of an improved method for controlling the speed of DC motors based on foraging strategy. *J. Bulg. Acad. Sci.*, 1: 51-56.
- Shelokar, P.S., V.K. Jayaraman and B.D. Kulkarni, 2004. An ant colony approach for clustering. *Anal. Chim. Acta*, 509: 187-195.