

Estimation of Carbon Dioxide Emission Using Adaptive Neuro-Fuzzy Inference System

¹Nur Rachman Dzakiyullah, ²Chairul Saleh, ³Fadmi Rina and ²Abdul Rahman Fitra

¹Department of Information Technology, Universitas Aisyiyah Yogyakarta, Yogyakarta, Indonesia

²Department of Industrial Engineering,

³Department of Informatics Engineering, Faculty of Industrial Technology,
Universitas Islam Indonesia, Yogyakarta, Indonesia

Abstract: Effect of CO₂ emission was highly risked toward the climate change which arising from a natural process and human activities. This study presents a model of Adaptive Neuro-Fuzzy Inference System (ANFIS) for estimating the CO₂ emission. This model is built based on input variables from the using of energy in producing the rubbing alcohol company which includes electrical energy and coal. The training of ANFIS analyzed by using hybrid LSE recursive then the performance of ANFIS analyzed by using RMSE. The experiment is performed by optimizing the parameter value of ANFIS. The proposed models are examined using a real word data as a dataset that was collected from rubbing alcohol company in Indonesia. The data was divided into 60% training data and 40% testing data. The experimental result shows that ANFIS provides small RMSE 0.0000259. It indicates that the ANFIS Model as a promising tool to ease company in estimating CO₂ emission and even can contribute to practice as a tool for decision making to control CO₂ emission.

Key words: Energy consumption, adaptive neuro-fuzzy inference system, estimation of CO₂ emission, examined, estimating, contribute

INTRODUCTION

Issues relating to Green House Gas emissions (GHG) become a major concern both from the perspective of governments, company and society for many people in the world. This problem has resulted in the development of local GHG inventories (Dodman, 2009). These issues have also induced the introduction of footprint calculation methodology (Druckman and Jackson, 2009). The biggest producer of GHG is Carbon dioxide (CO₂) which arise from natural processes and from human activities (Eggleston *et al.*, 2006). The growing of CO₂ is directly proportional to the increase of human population and economic activity. There are some parties who are responsible for controlling CO₂ emission. First, the government whose act as regulators which making appropriate policies in order to reduce CO₂ emission. Second, a manufacturing that fully responsible for the production process and delivery of products. The last parties are the amount of CO₂ emissions from the customers who have an awareness of the environmental damage. Each party required immediately control the emissions of CO₂ and should have the responsibility to reduce the impact of climate change (Fang *et al.*, 2011).

The concept of “carbon footprint” as references in the measurement of CO₂ emissions has attracted the attention of government, company and consumers (Wiedmann *et al.*, 2006). The industries are central to paving the way toward a low-carbon society, since, a large portion of CO₂ produced from industrial production (Hoffmann and Busch, 2008). More than 75% of the atmosphere is CO₂ that contributing to global warming. In order to reduce the climate change, the first thing to do is to reduce the amount of CO₂ emissions that produced from various activities (Shi *et al.*, 2012; Roos and Tjamemo, 2011). This problem is newly-emerging that still under discussion which is no unified and acknowledged method to calculate the carbon footprint (Dong *et al.*, 2014). A related study on managing problem CO₂ was given a significant contribution and become direction for another researcher in order to improve and make a decision with applying some method (Schmidt, 2009; Lenzen, 2008). Moreover, the guidelines for national greenhouse gas is another direction for calculating CO₂ emission (Eggleston *et al.*, 2006). The application of these concepts very useful for identifying the impact CO₂ emissions as a basic fundamental in order to determine the emission reduction strategies (Postorino and

Mantecchini, 2014). Because the CO₂ emissions were difficult to be calculated accurately. However, this research proposed the calculation of CO₂ emissions using one of soft computing technique based on the real data.

Literature review: Recently, soft computing technique increasingly used by researcher and practitioner to solve many problems, since this technique adopting human intelligence and have the ability to learn in the uncertainty environment (Sumathi and Surekha, 2010). According by Tian and Gao (2010) was studied the estimation of CO₂ emissions by using Artificial Neural Network Model (ANN). The study was considering variables such as coal consumption, energy efficiency, population, income per capita and consumption per capita. According by Hosoz *et al.* (2013) presented that ANFIS can be applied to estimate the emitted of CO₂ emission from diesel engines that using various fuels. The emitter of CO₂ emissions on these research is based on the variable performance of the engine, the air temperature, fuel specification and brake thermal efficiency. The results of these study can be seen that ANFIS has a good ability to solve the problems of estimating CO₂. Gholizadeh and Sabzi (2017) was developed ANN and ANFIS Models and successfully predict the carbon dioxide sorption in several Poly Ionic Liquids (PILs) with considering Group Contribution (GC) method. This study was allowing input variable such as the chemical structure of PILs, temperature, pressure and as output concentration of carbon dioxide in PIL as output. The result shows that both ANN and ANFIS Models were accomplished to predict CO₂ sorption. Moreover, the comparison between ANFIS Model and Artificial Neural Network (ANN) to estimate the concentration of Carbon Monoxide (CO) that contained in the daily Earth's atmosphere show that ANFIS Model gets the best results compared to the model ANN (Noori *et al.*, 2010). Another study was considering a model for managing the risk by buying and selling carbon emission futures. They develop three model and one of the models was an Adaptive Neuro-Fuzzy Inference System (ANFIS). Because ANFIS is a hybrid model that has the ability to self-learning without experts and universal estimator (Atsalakis, 2016; Ghiasi *et al.*, 2016). This shows the advantage that can be adobe for estimate carbon dioxide. It can be concluded that ANFIS Model has shown great performance in order to solve many problems and especially CO₂ emission. In this study, we implement ANFIS Model to solved CO₂ emission on rubbing alcohol company. The expectation of this model will provide a better result as a basis for decision-making in order to support firm's carbon management and will gain competitive advantage along with governmental policy-making.

MATERIALS AND METHODS

As mentioned in the previous study, we implement ANFIS Model to solved CO₂ emission on rubbing alcohol company. The step of this research showed in Fig. 1. The process of designing ANFIS Model was started from collecting real-world data such as Electrical energy, coal and CO₂ emission. The data is historical data that retrieved from rubbing alcohol company in Yogyakarta, Indonesia. The data is related to energy consumption that used from the beginning until the end of the production process including electrical energy in kilowatt-hour (kWh) and burning coal in kilogram (kg). Electrical energy is used to run the electric motors, lighting and for other purposes related to the production process. Another hand, coal is used for a steam boiler that is utilized in a distillation unit. Electrical energy and coal are selected as the variables because they directly affect the change of CO₂ emission.

The burning of fossil fuels produces CO₂ from the production process and transportation from suppliers to consumers (Wiedmann *et al.*, 2006). Moreover, CO₂ emission data are taken from the total emitted CO₂ from electrical energy consumption and coal. In order to calculate the CO₂ emission, all energy consumption must be converted first into the value of CO₂ emission (kg CO₂). There are several steps to implement this, first is to convert the value of electrical energy into the value of CO₂ emission. Second is converting the value of coal consumption into the value of CO₂ emission. The third is summing the value of CO₂ emission from electrical energy consumption and coal consumption. Conversion of electrical energy is obtained by multiplying the amount of energy used and the calorific value or emission factor.

$$E_{CO_2}^E = A_{(E)} \times EF_{(E)} \quad (1)$$

Where:

$E_{CO_2}^E$ = Total CO₂ Emission from electrical energy consumption (kg.CO₂)

$A_{(E)}$ = Electrical Energy used (kWh)

$EF_{(E)}$ = Electrical Emission factor (kg/kWh)

The value of the emission factor equal to 0.725 kg/kWh for electricity that has been determining Perusahaan Listrik Negara (PLN). The amount of CO₂ emissions combustion of fossil fuels results depends on many and the type of fuel burned. The amount of fuel represented as activity data while fuel types are represented by the emission factors. The equation used to estimate CO₂ emissions from coal are as follows:

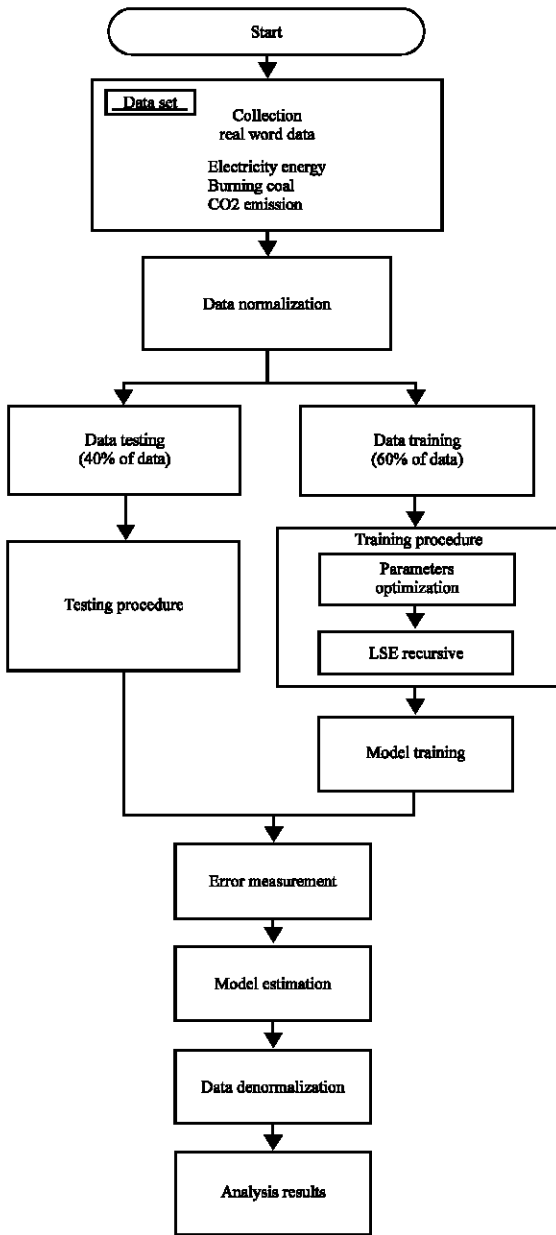

Fig. 1: Designing ANFIS Model for estimation CO₂

$$E_{CO_2}^c = A_{(c)} \times EF_{(c)} \tag{2}$$

Where:

$E_{CO_2}^c$ = CO₂ Emission from combusted fuel (kg.CO₂)

A (C) = Coal energy consumption (TJ)

EF (C) = Emission Factor (kg/TJ)

where A (C) must be converted first to:

$$A_{(c)} = Q \times P_v \tag{3}$$

Where:

Q = The quantity of coal energy used (kg)

P_v = Calorific value (TJ/kg)

Description: The next step, once historical data was analyzed and converted then in order to design ANFIS Model we determine variable electrical energies and burning coal are categorized as input variables. The output variable (CO₂ emission) data are taken from the total emitted CO₂ from electrical energy consumption and coal as mentioned before. The relationship between the input and output variables is defined as:

$$\begin{bmatrix} x_1 \\ \text{burning coal} \end{bmatrix} Y_1 = [\text{Carbon dioxide emission}] \tag{4}$$

X_i = Input attributes, Y_i = Output

Adaptive Neuro-Fuzzy Inference System (ANFIS) is a linear equation with variables that suitable for the input variables. ANFIS functionally same with fuzzy rule base TSK Model orde-1 as follows:

$$\begin{aligned} \text{IF } (x_1 \text{ is } A_1), \dots, (x_n \text{ is } A_n) \\ \text{THEN } z = p_1 * x_1 + \dots + p_n * x_n + q \end{aligned} \tag{5}$$

If α-predicate for both rules is w₁ and w₂ and fuzzy sets A_i, B_i, i = 1, 2 then the weighted average calculated by using this Eq. 6:

$$Y = \frac{w_1 y_1 + w_2 y_2}{w_1 + w_2} = \bar{w}_1 y_1 + \bar{w}_2 y_2 \tag{6}$$

ANFIS architecture consists of 5 structure. However, in this study, we determine the amount of neuron in every structure with 2 rules as follow:

- IF x₁ is A₁ and x₂ is B₁ and x₃ is C₁ and x₄ is D₁ then y₁ = C₁₁ x₁ + C₁₂ x₂ + C₁₀
- IF x₁ is A₂ and x₂ is B₂ and x₃ is C₂ and x₄ is D₂ then y₁ = C₂₁ x₁ + C₂₂ x₂ + C₂₀

Figure 2 shows the relation 2 inputs and 1 output where x₁ = Electrical energy, x₂ = Burning Coal and y₁ = CO₂ emission.

In Fig. 2, each layer has a different procedure. In the first layer, an adaptive node towards the parameters of activation functions. The output of each neuron is membership degrees that given by the input membership functions with maximum equal to 1 and minimum equal to 0 are calculated as follows:

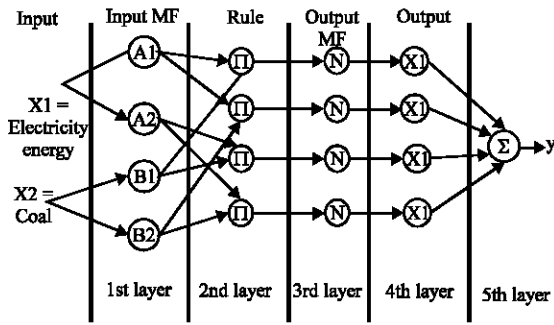

Fig. 2: ANFIS Model architecture with 2 rules

$$\mu_x = \frac{1}{1 + \left(\frac{x-0}{\alpha}\right)^{2b}} \quad (7)$$

With a, b and c as parameters, typically the value of the parameter b = 1, c is the mean value and a its standard deviation value is called the premise parameters. If the value of these parameters changes, the shape of the resulting curve will also change.

Layer 2: Each neuron is a fixed neuron and the output value is the result of input from the first layer. In the second layer, the operator that usually used is AND operator. Each node is presented firing strength of the rule number i.

$$\bar{\omega}_i = (\mu_{A_i(x)} * \mu_{B_i(y)}), i = 1, 2 \quad (8)$$

Layer 3: Each neuron in this layer is the result of ratio calculation from a predicate (w). The results in this layer are called the normalized firing strength.

$$\bar{\omega}_i = \frac{W_i}{W_1 + W_2} \text{ with } i = 1, 2 \quad (9)$$

Layer 4: Each neuron in this layer is adaptive towards an output node:

$$\bar{\omega}_i f_i = \bar{\omega}_i (C_{i1} x_1 + C_{i2} x_2 + C_{i0}) \text{ with } i = 1, 2 \quad (10)$$

ω_i is normalized fire strength in the third layer and {C₁, C₂, C₀} are the parameters in these neurons. Parameters in this layer are called the consequent parameters. Layer 5: Each neuron in the fifth layer is a fixed node which is the sum of all inputs and labeled as Σ:

$$\sum_{i=1}^2 \bar{\omega}_i f_i = \frac{\sum_{i=1}^2 \bar{\omega}_i f_i}{\sum_{i=1}^2 \bar{\omega}_i} \quad (11)$$

Normalization of input values for each measured attribute in the training will help speed up the learning stage. Data normalization is used to equalize the data among the attributes in order to obtain equal weight in the calculation of each attribute. Formula to normalize data is as follows:

$$X' = \frac{X - X_{\min}}{X_{\max} - X_{\min}} \quad (12)$$

After all data processing is done, the data that have been normalized will be denormalized in order to restore the real data and denormalized is used to compare the result of real data:

$$X = X' (X_{\max} - X_{\min}) + X_{\min} \quad (13)$$

The first step in ANFIS is to divide the data randomly into training data 60% and testing data 40%. The best model was selected based on the testing steps. Then several modifications were made in order to achieve the best result. A hybrid algorithm is used to set the parameters C_{ij} in advance (forward) and will set the parameters {a_i, b_i, c_i} is backward (Backward). At the time set advanced parameters, input the network will creep forward until the fourth layer and the parameters will be identified using the least-squares method. While, on a step back, the error signal will propagate backward and parameters {a, b, c} will be repaired by the method of gradient-descent. Results of the fourth layer output which is used as a parameter coefficient matrix in finding parameter values of C₁₁, C₁₂, C₁₀, C₂₁, C₂₂, C₂₀. Parameter values found using hybrid algorithms recursive LSE (Least Square Error Recursive). Calculated by using the equation:

$$P_{k+1} = P_k - \frac{P_k a_{k+1} a_{k+1}^T P_k}{1 + a_{k+1}^T P_k a_{k+1}} \quad (14)$$

$$\theta_{k+1} = \theta_k + P_{k+1} a_{k+1} (y_{k+1} - a_{k+1}^T \theta_k) \quad (15)$$

In this step, the adaptive network will be trained in order to get the value of the parameter a and c. The parameter a and c improved by using gradient descent error propagation model, so, the sum square error can be calculated with the following equation:

$$E_p = \sum_{k=1}^{N(L)} (d_k - X_{L,k})^2 \quad (16)$$

After the value of each parameter obtained, the output value of the fifth layer, it can be said that the network is complete ANFIS owned. Then, the performance evaluation designated to evaluate on how well the network can learn, so, it will be easily recognized when compared with the new pattern. Generalization error represents the difference between actual output and the target. To test how close, the approximation to the actual value, the measures that commonly used is the Root Mean Square Error (RMSE) where n is the total value of the observation that can be seen as follow:

$$RMSE = \sqrt{\frac{\sum (Actual - Prediction)^2}{n}} \quad (17)$$

RMSE is the sum of squared errors on the difference between the actual and the estimated value then divides that number by the amount of time and data estimation then pull the square roots.

RESULTS AND DISCUSSION

The tool that will conduct for this experiment is ANFIS Editor MATLAB r 2010 for estimate the emission of CO₂. ANFIS editor in MATLAB tools box offers different types of MFs, after doing the evaluations eventually Gbell MF yields the best result then epoch will be training until yielding the graphic of steady state and the best result is 200 epochs. The ANFIS parameter that used is hybrid Algorithm, error tolerance is used to create a training stopping criterion which is related to the error size. The training will stop after the training data error remains with this error setting in this study the error value is 0. Then the result after train the data with error value = 0, epoch = 200 and using hybrid optimization was shown in Fig. 3.

The result was obtained in developing CO₂ emission estimation model using ANFIS shows the error or RMSE 0.0000259. The training error shows that close to 0. However, we need to evaluate the training model with the testing data to understand that the estimation model was successfully trained.

The result shows that estimation model was satisfactory. As we can see in Fig. 4 that testing data

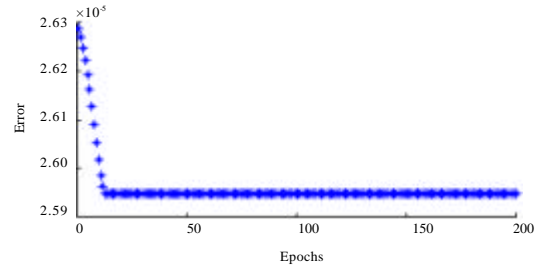

Fig. 3: Training error result

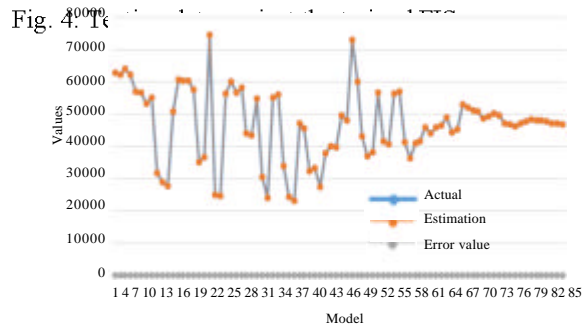
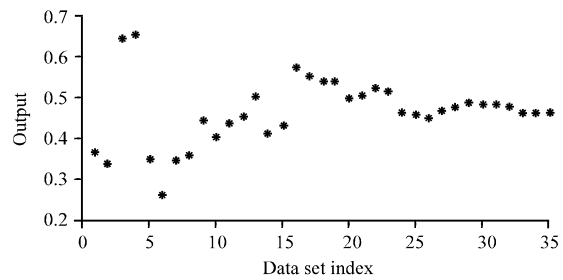

Fig. 5: Estimation result of ANFIS Model

(blue dot) was fit into data training (star). Moreover, to make sure the model was significantly optimized, we make another comparison from the data actual and the estimation result in Fig. 5.

Comparison between actual vs estimated data was performed by the denormalized process and the result shows the biggest error that occurred is 6.129 and the lowest result is 0.003. This value was representing differences between the actual data minus the estimated data.

Based on the experiment, the result on actual and estimation data was successfully designing model for estimate CO₂ emission.

CONCLUSION

This study focuses on the problem of greenhouse gases, especially, CO₂ emission that results from the production process. This research proposes the using of ANFIS Model to estimate the amount of CO₂ emissions. Training result showed the smallest error RMSE is 0.0000259, then the estimation result of ANFIS Model between actual output and estimation output show the lowest error is 0.003. Based on the experiment, ANFIS Model show has a good ability and good performance in order to solve the problem of estimations CO₂ emission.

RECOMMENDATIONS

For further research, several recommendations are to extend this research by adding a number of rules on ANFIS Model or add the number of input variables which certainly has a correlation to the variable output. The contribution in this study as practice giving awareness for the company about the damage of CO₂ emission for the environment, particularly in deciding the best way to reduce CO₂ emission.

ACKNOWLEDGEMENTS

The researcher would like to thank the anonymous reviewers for their valuable comments. This research is supported by Directorate of Research and Community Service and Board Academic Development, Universitas Islam Indonesia.

REFERENCES

- Atsalakis, G.S., 2016. Using computational intelligence to forecast carbon prices. *Appl. Soft Comput.*, 43: 107-116.
- Dodman, D., 2009. Blaming cities for climate change? An analysis of urban greenhouse gas emissions inventories. *Environ. Urbaniz.*, 21: 185-201.
- Dong, Y., B. Xia and W. Chen, 2014. Carbon footprint of urban areas: An analysis based on emission sources account model. *Environ. Sci. Policy*, 44: 181-189.
- Druckman, A. and T. Jackson, 2009. The carbon footprint of UK households 1990-2004: A socio-economically disaggregated, quasi-multi-regional input-output model. *Ecol. Econ.*, 68: 2066-2077.
- Eggleston, S., L. Buendia, K. Miwa, T. Ngara and K. Tanabe, 2006. 2006 IPCC guidelines for national greenhouse gas inventories, volume 4: Agriculture, forestry and other land use. IPCC National Greenhouse Gas Inventories Programme Technical Support Unit, Institute for Global Environmental Strategies (IGES), Kamiyamaguchi, Hayama, Kanagawa, Japan.
- Fang, K., N. Uhan, F. Zhao and J.W. Sutherland, 2011. A new approach to scheduling in manufacturing for power consumption and carbon footprint reduction. *J. Manuf. Syst.*, 30: 234-240.
- Ghiasi, M.M., M. Arabloo, A.H. Mohammadi and T. Barghi, 2016. Application of ANFIS soft computing technique in modeling the CO₂ capture with MEA, DEA and TEA aqueous solutions. *Intl. J. Greenhouse Gas Control*, 49: 47-54.
- Gholizadeh, F. and F. Sabzi, 2017. Prediction of CO₂ sorption in poly (ionic liquid)s using ANN-GC and ANFIS-GC models. *Intl. J. Greenhouse Gas Control*, 63: 95-106.
- Hoffmann, V.H. and T. Busch, 2008. Corporate carbon performance indicators: Carbon intensity, dependency, exposure and risk. *J. Ind. Ecol.*, 12: 505-520.
- Hosoz, M., H.M. Ertunc, M. Karabektas and G. Ergen, 2013. ANFIS modelling of the performance and emissions of a diesel engine using diesel fuel and biodiesel blends. *Applied Thermal Eng.*, 60: 24-32.
- Lenzen, M., 2008. Double-counting in life cycle calculations. *J. Ind. Ecol.*, 12: 583-599.
- Noori, R., G. Hoshyaripour, K. Ashrafi and B.N. Araabi, 2010. Uncertainty analysis of developed ANN and ANFIS models in prediction of carbon monoxide daily concentration. *Atmos. Environ.*, 44: 476-482.
- Postorino, M.N. and L. Mantecchini, 2014. A transport carbon footprint methodology to assess airport carbon emissions. *J. Air Transp. Manage.*, 37: 76-86.
- Roos, E. and H. Tjarnemo, 2011. Challenges of carbon labelling of food products: A consumer research perspective. *Br. Food J.*, 113: 982-996.
- Schmidt, H.J., 2009. Carbon footprinting, labelling and life cycle assessment. *Int. J. Life Cycle Assess.*, 14: 6-9.

- Shi, V.G., S.C.L. Koh, J. Baldwin and F. Cucchiella, 2012. Natural resource based green supply chain management. *Supply Chain Manage.: Int. J.*, 17: 54-67.
- Sumathi, S. and S. Paneerselvam, 2010. *Computational Intelligence Paradigms: Theory and Applications using MATLAB*. 1st Edn., CRC Press, Boca Raton, Florida, USA., ISBN:9781439809037, Pages: 851.
- Tian, L., L. Gao and P. Xu, 2010. The evolutionary prediction model of carbon emissions in China based on BP neural network. *Int. J. Nonlinear Sci.*, 10: 131-140.
- Wiedmann, T., J. Minx, J. Barrett and M. Wackernagel, 2006. Allocating ecological footprints to final consumption categories with input-output analysis. *Ecol. Econ.*, 56: 28-48.