

Design and Implementation of an Automated Residential Water Heating System using Sustainable Energy and PLC Techniques

Enaam Albanna, Hassaan Th. H. Thabet and Zozan Saadallah Hussain
Department of Electrical Technology, Technical Institute of Mosul,
Northern Technical University, Mosul, Iraq

Abstract: The objective of this study is to design a control system for the provision of water and hot water around the clock for people living in difficult times and abnormal conditions in their residential areas using solar energy as sustainable and free energy and water of wells. This study was accomplished during the severe electricity crisis that occurred in the city of Mosul/Iraq in the Winter of 2014 where the electricity supply to the city by the National Electricity Authority NEA does not exceed 2 h for every 72 h and the temperature of the atmosphere varies between -3 and 14°C and semi-disappearance of other sources of energy such as oil, cooking gas and gasoline as well as the interruption of water supply by the government water purification plant as a result of the electrical power cuts. The best solution was to take advantage of solar water heating and private generators (the Zone Generators, ZG) in the area which supply a number of houses (3 h ON/3 h OFF) throughout the day. The LOGO![®] V7.0 programmable logic controller from SIEMENS of Germany was used to control this system which consists of 1-the main electric water heater (Capacity 220 Ls). The auxiliary electric water heater (Capacity 30 L) for emergency cases. The solar heater which consists of two flat bed panels to collect solar radiation with a heat exchange tank (Capacity 180 L). The electrical control valves (Coil voltage 12 VDC). The main water storage tank at the top of the house (Capacity 1100 L) that is equipped with water either by the government water purification plant or by the water of the well in the case of the interruption of the first source using a water pump that will supply the main tank with water when needed. The solar electric cell that charges-in emergency cases-the battery which supplies the controller, sensors and actuators to ensure the sustainability of the operation of the control system, even in the complete absence of electricity. The test period of this system was from 1/10/2014 until 1/6/2015. The results of the test were good, especially, during the cold season during the month of January, 2014.

Key words: PLC, flat plate solar collector, Automatic Transfer System (ATS), sensors, capacity, equipped

INTRODUCTION

Figure 1 shows the main parts of the control scheme it consists of the following parts. The automatic transfer switch which supplies the load either from NEA or from ZG according to their availability. The PLC (Siemens, 2013; PT., 1989; Rashid, 2011; Hugh, 2010) that is used to control and automate the whole process, its specifications are:

- DC/DC/relay
- 8 digital inputs or 6 digital inputs +2 analog inputs
- 4 relay outputs
- An extension module with 8 digital inputs and 8 digital outputs

The electric heater elements (H1 and H2) which can be operated only during the savailability of NEA. The

standby battery charging system to supply the DC loads which are the PLC, the analog thermostat, the solenoid valves and the actuators of the H3 and H4. The solenoid Valves (V1-V6) (Va and Vb) and the actuators of the electrical heater elements (H3 and H4) which are controlled by the PLC as outputs (Operating Voltages 12 VDC):

- One analog temperature sensor (thermostat) which is fed as an input to the PLC (PT., 1989)
- One analog thermometer to measure the outlet temperature of the hot water
- A photovoltaic solar cell (Thabet, 2014) (PV) is used for emergency battery charging to sustain the activation of the whole system even in the absence both NEA and ZG (Current 2A, Voltage 12 V, safety factor 1.25)

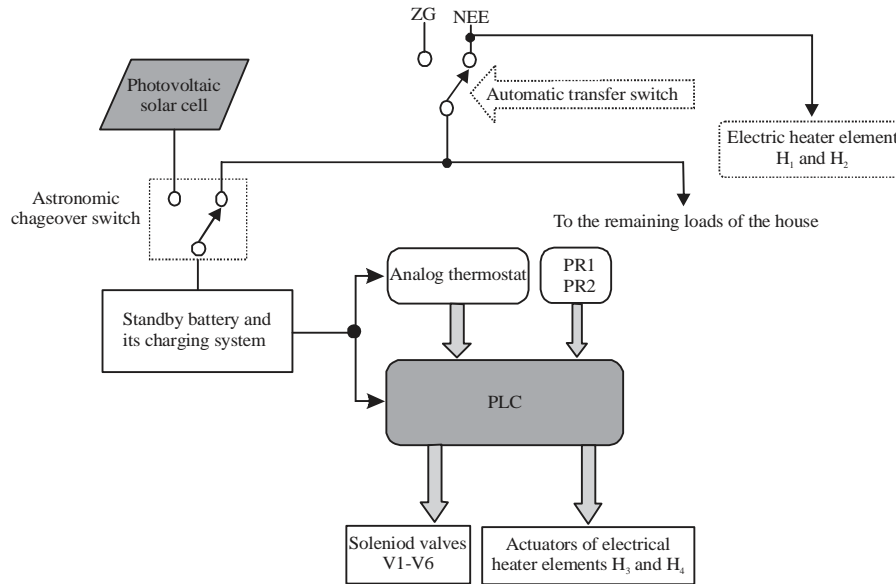

Fig. 1: Main parts of the electric scheme

MATERIALS AND METHODS

Hardware task

Installation works: As shown in Fig. 2, our system is functioning in the following manner. The main water tank that receives water from main water supply by Va or Vb and supplies the whole system with water via. solenoid Valve V1. An analog thermostat is used to measure the temperature of its water (as input temperature of the system) and conveys it to an analog input of the PLC for control purposes.

Two flat plate solar collectors with their storage tank whose input is controlled by solenoid Valve V2 and its outputs are controlled by solenoid Valves V3 and V5. An electrical heater element H4 is immersed in the storage tank.

The main electric water heater with two electrical element Heaters H1 and H2 its inlet is controlled by two solenoid valves V3 and V6. An Auxiliary electric water heater with electrical element Heater H3 its input is controlled by the solenoid Valve V4. A thermometer is available at the outlet of the system for measuring the temperature of the hot water supplied to consumers as an output temperature of the system.

Electrical works: Figure 3 shows a complete electrical circuit diagram of the system, it describes an Automatic Transfer Switch (ATS) which contains of two main Contactors (C1 and C2) to supply the load either from NEA (C1) or from ZG (C2) and two Pilot Relays (PR1 and PR2) which monitor the availability of NEA and ZG. The electric heater elements (H1 and H2) of the main electric water heater, the rating of each of them is

3000 W they are connected directly to the NEA (L1 and N). The electric heater element H4 whose rating is 500 W was equipped with the solar heating system. It can be operated by both NEA and ZG via. PLC by Contactors C5 and C4, respectively. The electric heater element H3 whose rating is 1000 W can be operated only by ZG via. PLC by Contactor C3. Each one of the heater elements (H3 and H4) is connected in series with a diode (Rashid, 2011) as a very simple and inexpensive way to reduce power to resistive loads (electrical heater elements) as shown in Fig. 4 which will lead to decrease the current dragged from the ZG.

A battery charger is also connected to the output of the ATS, so, it can be operated by both NEA and ZG, it charges a battery (12 VDC/75 AH) which maintains electrical power to the PLC, its extension modules, actuators and sensors. In order to sustain the supplying of electrical power for our loads, a PV solar cell is used to charge the same battery in the absence of NEA and ZG at day periods. DC electric power is supplied to an inverter that supplies emergency AC loads at night periods and also in the absence of both NEA and ZG such as led lighting fixtures. The inverter can be operated manually by a manual switch according to the consumer needs as shown in Fig. 5.

Figure 5, 6 and 8 describe the operation of the changeover relay and the astronomical clock in order to maintain the supplying of the electrical power to the loads in the following manner.

The most important target for this optional standby system is to maintain supplying the PLC, its control system and the emergency loads with electrical power. As shown in Fig. 5 the PLC and its control system are

Table 1: The possible cases that could take place when the system is in operation

Cases	NEE	ZG	V1	V2	V3	V4	V5	V6	H1 and H2	H3	H4
Case one	1	0	1	0	0	0	0	1	1	0	0
20°C =<T _w > =30°C	0	1	1	1	0	0	1	0	0	0	(1)0
Case two	1	0	1	1	1	0	0	0	1	0	(1)0
10°C =<T _w <20°C	0	1	1	1	0	0	1	0	0	0	1
Case three	1	0	1	1	1	0	0	0	1	0	1
3°C =<T _w <10°C	0	1	1	0	0	1	0	0	0	1	0
Case four emergency	0	0	1	1	0	0	1	0	0	0	0

Software design: To understand the operating basis of this system, Table 1 describes the possible cases that could take place when the system is operated:

- V1, V2, V4 and V6 are valves supplying cold water
- V3 and V5 are valves supplying hot water
- 1 means that the valve is opened (ON state)
- 0 means that the valve is closed (OFF state)
- T_w water Temperature of the main tank
- 1 activated at night or cloudy periods

Case one: The first part of this case is accomplished when the following conditions are available:

- The electricity is supplied by NEA
- The temperature of the water in the main water tank is 20-30°C or more

So, two valves are opened V1 and V6 as shown in Fig. 2 also the built-in thermostats of the heater elements H1 and H2 are to be set at 50 and 65°C, respectively. This case is the normal case and it could be utilized at day or night periods.

The second part is accomplished in case of the absence of NEA and the temperature of the water in the main water tank is also 20-30°C or more and the ZG supplies the load then V6 will be closed, V2 and V5 are opened, so, hot water will be supplied to consumers without any electrical power consumption at sunny day periods whereas at night or at cloudy day periods heater element H4 will be activated to compensate for the solar system.

Case two: In order to improve the efficiency of the system at day periods when the climate gets colder and the temperature of the water in the main water tank goes <20°C with the availability of electricity supplied by NEA, then case two is utilized in the following manners. Valves V1, V2 and V3 are opened to supply water to the main electric water heater via. the solar heating system. At a sunny day period, the solar water heating system will raise the temperature of the water entering the main electric water heater and reducing its heating period.

At night or a cloudy (rainy) day periods, the heater element H4 (500 W) inside the storage tank of the solar water heating system will be activated to raise the temperature of the water entering the main electric water

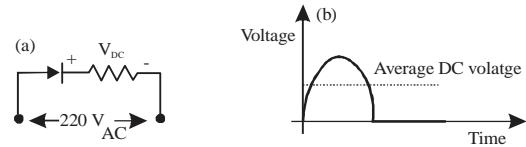

Fig. 4 (a-b): Half wave diode rectification

heater and also reduces the heating period. The built-in thermostat of the heater element H4 is to be set at 40°C. In case of the absence of NEA, the temperature of the water in the main water tank is also <20°C and ZG supplies the load then V3 is closed, V2 and V5 are opened to supply hot water for consumers.

Case three: This case states that when the weather becomes colder (2-3°C), the hot water is supplied to consumers from the main electric water heater tank via. the solar heating system with H4 is activated during sunny or cloudy periods daily and also at night periods when NEA is available by opening V2 and V3. In the absence of electricity supplied by NEA, the house will be supplied with electricity by ZG, so, the solar heating system will supply hot water directly to the consumers by opening the Valves V2, V5 at sunny day periods with the activation of H4. The heater element will be energized via. a power diode to decrease its power consumption. At night periods or at cloudy and rainy days, the valves V1 and V4 are opened and hot water is supplied to the consumers from the auxiliary electric water heater whose heating element H3 is rated (1000 W) and its built-in thermostat is set at 65°C, the heater element will be energized via. a power diode to decrease its power consumption.

Case four (emergency): When a complete electrical power failure takes place (neither NEA is available nor ZG), a photovoltaic solar cell is used during the day light period for charging the battery in order to activate V1, V2 and V5. In this case hot water will be supplied directly to the consumers by solar system during a day period (the charging efficiency of this system depends on the state of the weather of the day period). At night, the consumers will be supplied from the residual water in the storage tank of the solar system. The changeover relay that switches the charging process from NEA or ZG to the photovoltaic solar cell is featured with a special function

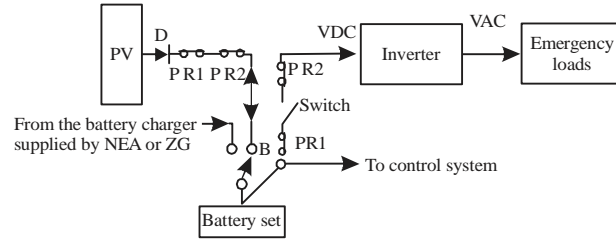

Fig. 5: A schematic diagram for a sustainable power supply

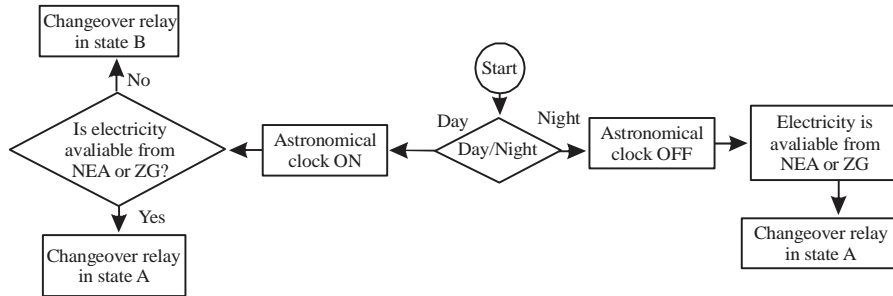

Fig. 6: Flowchart of the astronomical clock and the changeover relay

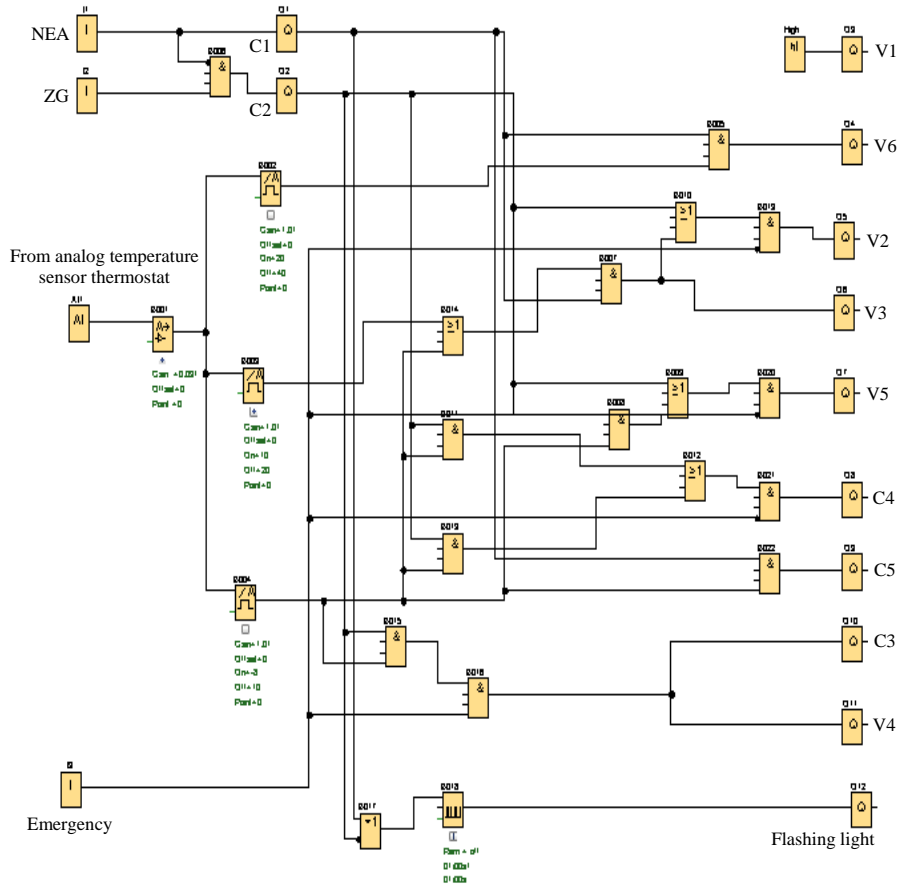

Fig. 7: FBD program of the system

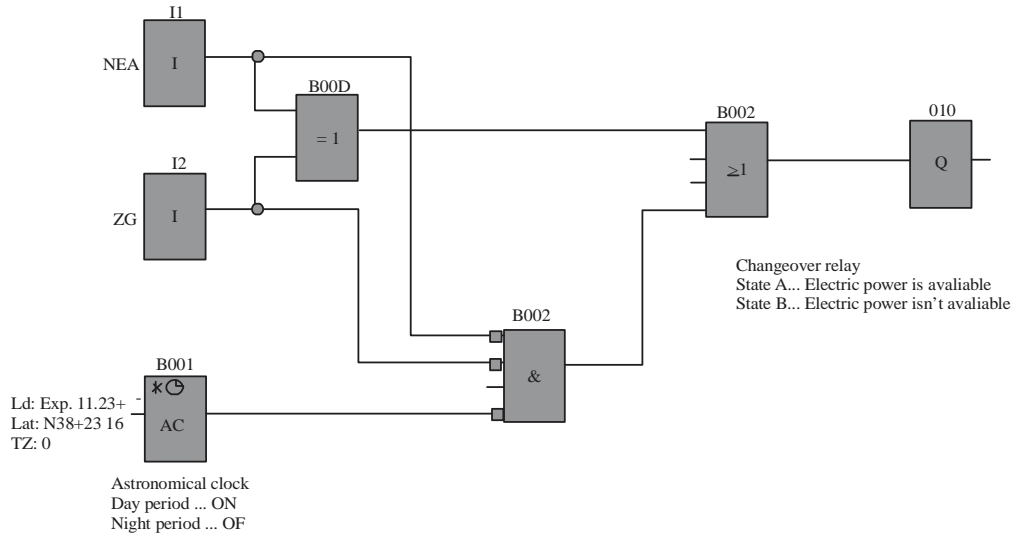

Fig. 8: Application of the astronomical clock in the control system

available in the software used in this study that is called “Astronomical clock” (Siemens, 2013) this function is used to set a high output from sunrise to sunset based on the local time at the geographical location of the LOGO! V7 (Siemens, 2013). The utilization of this function in our control program is described in Fig. 8. In case of emergency, the control system will be activated automatically whereas the emergency loads that are supplied with electricity by the inverter will be activated manually by the consumers according to their needs via a switch as described in Fig. 5.

Description of the program: A complete FBD (Function Block Diagram) program of our system is shown and described in Fig. 7, the heart of this program is the analog part of this program, it consists of an analog input which receives the temperature values of the main water tank from an analog temperature sensor an analog amplifier amplifies the analog input value and conveys it to the analog threshold trigger function block which reads the value of the signal; evaluates it and gives an output which can be set or reset depending on the threshold values (Siemens, 2013) this part of the program monitors the temperature of the water contained in the main tank and controls the switching of the solenoid valves and heater contactors in the system. A flashing light is added to the design of this system to inform the consumers that there is no power supplying the load which means that both NEA and ZG are OFF. The emergency push button shown in Fig. 7 can be actuated manually by the consumers for urgent needs of hot water during very cold weather at night periods when ZG is available (the hot water is supplied by the auxiliary electric water heater). Figure 8

below describes the role of the astronomical clock in our control system; the astronomical clock determines the latitude and the longitude of the location of our existing experiment and sets the sunrise and sunset timings of this location (Siemens, 2013) to benefit from solar system when both NEA and ZG are cutoff (day or night) as shown in the flowchart of Fig. 6.

RESULTS AND DISCUSSION

Our water heating system is able to heat and supply approximately 80-120 L of hot water (its temperature is between 45 and 50°C) in normal cases around the clock but in abnormal cases, the temperature of the hot water decreases to around 30°C. In emergency cases (at night and very cold weather) with the availability of ZG, the auxiliary electric heater can supply approximately 20 L of hot water whose temperature is around 50°C within 40 min. Figure shown below, describes the practical part of our research, Fig. 9 shows the main and auxiliary electric water heaters, some valves and the heater element H3. Fig. 10 shows the main water supplying tanks, the solar heating system and the electrical heating element H4. Figure 11 shows the main part of the controlling system (in this research the HMI is not used) other parts of the control system are inside the control panel. To explain how our system is functioned, temperature readings of the main tank water (as input temperature) and the tap hot water (as output temperature) were taken twice daily at December (from 1-31st), the first reading at 12:00 AM and the second reading at 12:00 PM, the average of the two input

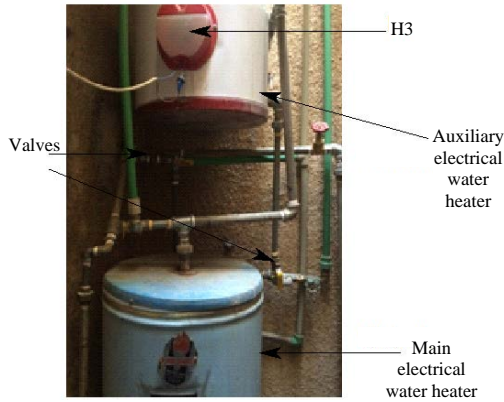

Fig. 9: Electric water heaters

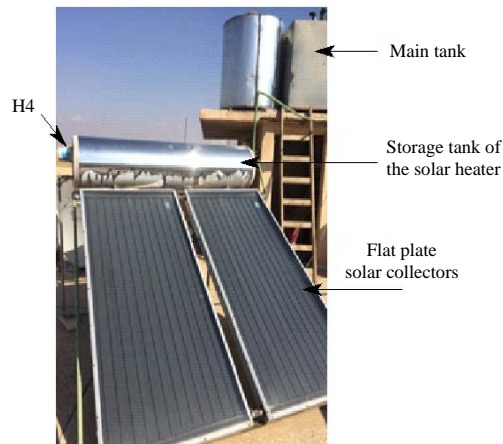

Fig. 10: Solar water heating system



Fig. 11: Main part of the controlling system

temperatures and the average of the two output temperatures were recorded calculated and sketched as shown in Fig. 12. Two dips in output water temperature are shown in Fig. 12 due to cloudy weather on the 8th of December and due to cloudy and rainy day on the 20th of December.

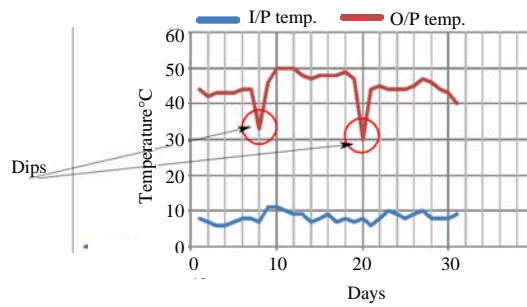

Fig. 12: I/O temperatures in December, 2014

CONCLUSION

The water heating system designed and implemented in this study gives very good results when used at the needed period of the year from the 1st of October to the 1st of June, especially, at December, January and February because it supplies the consumers with sufficient amounts of hot water around the clock with the absence of the NEA. For future scope, it is important to evaluate how well this heating system performed which means that the efficiency of this system must be calculated. Also, an HMI (Human Machine Interface) could be included in our automated system to make it interactive with the users.

ACKNOWLEDGEMENT

Taking this opportunity to extend our thanks to Mr. H. Thabet for implementing our research in his home and recording all the measurements and notes during the practical period of our research.

REFERENCES

Hugh, J., 2010. Automating Manufacturing Systems with PLCs. Lulu Press, Morrisville, North Carolina, USA., ISBN:9780557344253, Pages: 644.

PT., 1989. PT100 platinum resistance thermometers. Pico Technology, St Neots, England,UK. <http://www.picotech.com/applications/pt100.html>

Rashid, M.H., 2011. Power Electronics Handbook: Devices, Circuits and Applications. 3rd Edn., Elsevier, Burlington, Massachusetts, USA., ISBN:978-0-12-382036-5, Pages: 1389.

Siemens, 2013. Siemens LOGO! 0BA6 & 0BA7. Siemens Automation company, Munich, Germany.

Thabet, H.T.H., 2014. Design and implementation of a two axis solar tracking system using PLC techniques for measuring solar radiation by an inexpensive method?. Buhuth Mustaqbaliya Sci. Period. J., 1: 11-28.