

## Viscosities of Palm Oil and Palm Wine as Quality Indicators

<sup>1</sup>J.C. Osuwa and <sup>2</sup>S.U. Mbamara

<sup>1</sup>Michael Okpara University of Agriculture, Umudike, Abia State, Nigeria

<sup>2</sup>Federal University of Technology, Owerri, Imo State, Nigeria

**Abstract:** The viscosities of various grades of two local fluids, palm oil and palm wine, commonly produced in Eastern part of Nigeria, have been investigated using a locally fabricated viscometer. The results show that viscosity of palm wine tails with fermentation to produce alcohol, while that of palm oil remains independent of the free fatty acid content which determines its quality.

**Key words:** Viscosity, palm oil, palm wine, fermentation, viscometer

### INTRODUCTION

In the wake of increased emphasis on local raw materials inputs in Nigerian industries, the need for accurate documentation of both physical and chemical properties of potential raw materials has become more urgent. Fluids such as palm oil, palm wine, vegetable oil, etc., which are local to Nigeria form part of these resources for which accurate information on density, boiling point, viscosity, thermal conductivity, etc. are desirable in order to broaden their scope of applicability.

In the present study, the viscosities of palm wine and palm oil have been measured using a viscometer constructed at the Physics Laboratory of Federal University of Technology, Owerri. Measurements were made on different samples of palm oil collected from different production units. In the case of palm wine, the viscosity was measured on daily basis as the sample underwent fermentation. Attempts were then made to relate the viscosity values to the qualities of the fluids.

### THEORY OF MEASUREMENTS

The governing equation for laminar flow of an incompressible fluid of density  $\rho$  and viscosity  $\mu$  is according to Navier Stokes equation (Bird *et al.*, 1960) given by

$$\rho \frac{d\mathbf{v}}{dt} = -\nabla p + \mu \nabla^2 \mathbf{v} + \rho \mathbf{g} \quad (1)$$

In a steady state condition of flow along a horizontal tube, Eq. 1 becomes

$$\mu \nabla^2 \mathbf{v} = \nabla p \quad (2)$$

For a cylindrically symmetric tube of length  $\ell$  and radius  $R$  the equation of flow in the axial direction takes the form

$$\frac{d^2 v}{dr^2} + \frac{1}{r} \frac{dv}{dr} = \frac{1}{\mu} \frac{\Delta p}{\ell} \quad (3)$$

where,  $\Delta p$  is the pressure difference between 2 points  $\ell$  distance apart.

The solution to Eq. 3 with the aid of the no-slip condition (Yuan, 1960) at the wall of the tube is

$$v = \frac{R^2 \Delta p}{4\mu \ell} \left[ 1 - \left( \frac{r}{R} \right)^2 \right] \quad (4)$$

The volume flow rate  $Q$  is then

$$Q = 2\pi \int_0^R v(r) r dr \quad (5)$$

Leading to the Poiseuille formula

$$Q = \frac{\pi R^4 \Delta p}{8\mu \ell} \quad (6)$$

Equation 6 provides the basis for the determination of viscosity  $\mu$ . Thus by measuring the volume flow rate  $Q$  and the pressure difference  $\Delta p$  and with  $R$  and  $\ell$  preselected,  $\mu$  is readily evaluated.

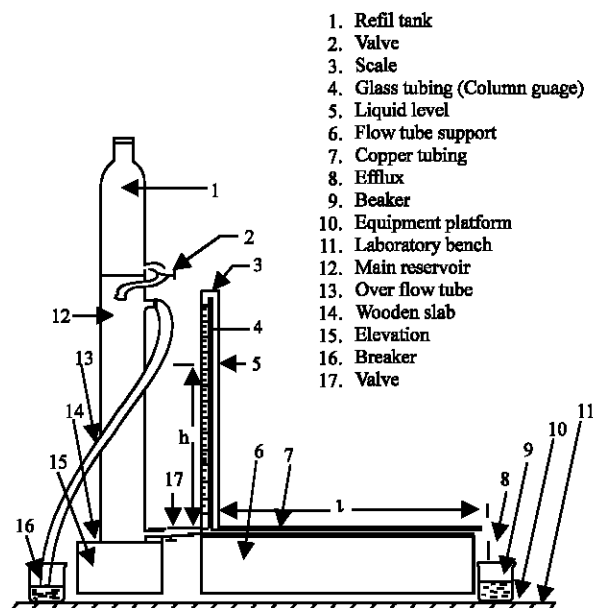

Fig. 1: Parallel flow viscometer

**MATERIALS AND METHODS**

A locally constructed Saybot-type viscometer, (Yuan, 1960) used for the measurements is depicted in Fig. 1. It consists of a capillary tube of flow fixed to the base of cylindrical reservoir which holds the liquid to be investigated. The capillary tube is fitted with a valve for regulating the flow and a manometer which measures the pressure difference between the ends of a flow region. To ensure a steady state condition, the flow along the capillary tube is gravity fed by a constant pressure head, with the manometer positioned where the flow has become fully developed.

A refill tank maintains the fluid in the reservoir at a steady level. This level corresponds to a vent through which any excess fluid overflows. Five measurements of each fluid were then made at room temperature. Only the average experimental values have been reported in this study.

**RESULTS AND DISCUSSION**

The efficiency of the new viscometer was first ascertained by measuring the viscosities of some standard fluids. Table 1 shows the results of measurements for water, isopropyl alcohol and carbon tetrachloride along with standard values from the literature. Considering the temperature dependence of viscosity, the two sets of values are in good agreement, thus confirming the reliability of the equipment.

Table 1: Viscosities of some standard fluids

Fluid	Standard viscosity $\mu$ (cp)	Experimental viscosity $\mu$ (cp)
Water	0.8327 at 28°C	0.8418 at 28°C
Isopropyl alcohol	1.770 at 30°C	1.5500 at 33°C
Carbon tetrachloride	0.843 at 30°C	0.8566 at 30°C

Table 2: Viscosity of palm wine as function of age

A. Oil palm wine		B. Raphia palm wine	
Age (days)	Viscosity (cp)	Age (days)	Viscosity (cp)
1	1.00 at 30°C	1	1.04 at 31°C
2	0.949 at 31.2°C	2	1.01 at 31.5°C
3	0.934 at 31°C	3	1.00 at 32°C
4	0.935 at 29°C	4	0.985 at 30°C
5	0.916 at 30°C	5	0.962 at 30.4°C
7	0.921 at 29.7°C	7	1.00 at 29°C
10	0.932 at 28.8°C	10	1.01 at 28°C

Table 3: Viscosity of palm oil with corresponding F.F.A. content

Specimen	Source	Viscosity (cp)	F.F.A. as % palmitic acid
A	Ohaji	47.03 at 27.8°C	7.0095
B	Nekede	45.7 at 28°C	10.0044
C	Amandugba	47.52 at 27.8°C	11.9288
D	Orodo	48.17 at 27.4°C	14.2223
E	Oguta	46.26 at 27.6°C	17.7658

The varieties of palm wine-raphia palm wine and oil palm wine-were then investigated. Table 2 shows the measured viscosity values as a function of duration of the palm wine. As evident in Table 2, there is a gradual decrease in the viscosity of both varieties of palm wine during the first 3 days. This corresponds to a period of active fermentation. Beyond the third day the temperature dependence of viscosity becomes more predominant.

These results suggest that the viscosity of palm wine decreases as it ferments to produce alcohol. In the absence of temperature effects the viscosity tends to remain constant after fermentation. The results also reveal that raphia palm wine has a slightly higher viscosity than oil palm wine.

Investigation of palm oil, involved 5 specimens from different production centers at Ohaji, Nekede, Amandugba, Orodo and Oguta. The measured viscosity of each specimen is contained in Table 3.

Additionally, the Free Fatty Acid (F.F.A) content of each specimen was determined by titrimetric method, (Snell and Ettore, 1971). The result is also shown in Table 3 as the percentage palmitic acid present in each specimen. Free Fatty Acid content of palm oil determines its quality (Bender, 1982) and its determination here is to enable us observe any relationship that may exist between viscosity and Free Fatty Acid content of palm oil. The results however show no regular trend between these two quantities. Observed substantial differences in the F.F.A content of the various specimen are thus attributable to the degree of purification of each specimen.

### **CONCLUSION**

A simple and reliable instrument for routine measurement of viscosity has been developed in this study. Variations in room temperature constitute the major difficulty during its use. Incorporation of temperature control system to maintain constant temperature during measurement is thus recommended.

However, the viscosities of both palm wine and palm oil reported here have been accurately determined for the specified temperatures. A decrease in the viscosity of palm wine due to fermentation has also been established. Fresh palm wine, thus has higher viscosity than the more alcoholic and aged palm wine.

Viscosity being the main flow characteristic of fluids, determines the quality or class of a fluid. The quality of consumable fluids like palm oil and palm wine after a period of preservation, can therefore be assessed by measuring their viscosity at room temperature. Any significant loss or gain in viscosity will be indicative of deterioration in the fluid quality, irrespective of whether or not there is any discernible change in taste. The knowledge of viscosities of our local fluids may also lead to the discovery of good and new lubricants and together

with knowledge of other physical and chemical properties, may further lead to the discovery of new coolants and electrolytes. The need therefore, exists for further investigations in these areas.

### **ACKNOWLEDGEMENT**

The authors wish to thank the palm oil production centers at Ohaji, Nekede, Amandugba, Orodo and Oguta for providing the specimen used in this study. Appreciation also goes to Federal University of Technology, Owerri for funding the project.

### **REFERENCES**

- Bender, A.E., 1982. Dictionary of Food Technology. Butterworths, pp: 97-98.
- Bird, R.B., W.E. Stewart and E.N. Lightfoot, 1960. Transport Phenomena John Wiley and Sons Inc., pp: 76-81.
- Snell, F.D. and L.S. Ettore, 1971. Encyclopedia of Industrial Chemical Analysis. Interscience, pp: 8.
- Yuan, S.W., 1960. Foundations of Fluid Mechanics, pp: 265-275.