



## Thermal Conductivity of N-Tetracosane During the Solid/Liquid Phase Change

F.R. Gabitov, N.Z. Shakirov, F.D. Yuzmukhametov, R.A. Sharafutdinov, R.F. Gabitov and F.M. Gumerov  
*Kazan National Research Technological University, Kazan, Russia*

**Key words:** H-alkanes, n-tetracosane, paraffin, thermal conductivity, phase change

### Corresponding Author:

F.R. Gabitov  
*Kazan National Research Technological University,  
Kazan, Russia*

Page No.: 358-364

Volume: 14, Issue 10, 2019

ISSN: 1815-932x

Research Journal of Applied Sciences

Copy Right: Medwell publications

**Abstract:** Experimental thermal conductivity values have been obtained in the region of the solid/liquid phase change for  $C_{24}H_{50}$  (n-tetracosane) a representative of the n-alkanes at the atmospheric pressure and the temperature range of 312.85-325.16 k and temperature logs for mixtures of n-alkanes (paraffin) from  $C_{19}H_{40}$  (n-nonadecane) to  $C_{35}H_{72}$  (pentatriacontane) during melting (296.60-359.59 k) and crystallizing (317.25-349.45 k) using the transient hot wire method. Transition temperatures have been determined: solid state/solid state (triclinic-rhombic transformation) at 315.65 k, solid state/solid state (rhombic-hexagonal transformation) at 316.95 k and solid state/liquid at 322.34 k.

## INTRODUCTION

In the midst of a significant depletion of low and medium-density oil deposits, the problem of increasing oil yields by means of involving high viscosity oils in the extraction has become a topical issue on the global scale. The share of heavy and high-viscosity oils in the global oil extraction has reached 25%. Up to one quarter of the Russian deposits of heavy and high-viscosity oils is concentrated in the Volga-Urals oil province. Their largest share-up to 80% is within the territory of the Republic of Tatarstan. One of the obstacles that occur when extracting the high-viscosity oil and when pumping it through the pipelines is the viscosity. The kinematic viscosity of such oil in particular, during the winter period (at  $T \approx 240$  k) sometimes reaches 1000 mm<sup>2</sup>/sec. Oil processing companies of the Republic of Tatarstan employ 2 methods at the same time to reduce the viscosity during the Winter period to be able to pump the oil through pipelines from the well to the crude oil treatment refinery. An additive "Completex" is introduced to the oil to reduce the viscosity up to three times and the oil is additionally heated with boiler units. Along with the boiler units, booster pumping stations are installed along the pipelines. In order to eliminate the cavitation effect before the booster pumping stations, the associated gas

dissolved in the oil is removed. The pumping pressure is set as 2.5-2.6 Mpa, although, the equipment is capable of maintaining the pressure at 5-6 Mpa. Thus, if the price of the additive is RUR 1 Mio per 1 ton and the length of the pipeline is 17 km, the prime cost of the oil during the winter period is increased by up to 50%! It is known that the kinematic viscosity of the average highly viscous oil of the Volga and Urals oil province under the strata conditions (R&T) at the depth of 1000-2000 m is approximately 125 mm<sup>2</sup>/sec. Such viscosity value favorable for pumping the oil is not only explained with a high temperature in the stratum ( $T \geq 310$  k) but to a greater extent with the associated gas dissolved in the oil. Thus, values of critical parameters ( $T_{cr} = 205.01$  k;  $P_{cr} = 6.0425$  Mpa) calculated using the REFPROP Software for the oil-associated gas with the composition stated with the following shares by weight: methane -0.82672; ethane -0.077379; nitrogen -0.049807; propane -0.020751; CO<sub>2</sub> -0.011696; isobutene -0.003426; n-butane -0.005163, etc., evidence that such gas can be in the super-critical state at the stratum conditions. If the oil occurrence depth is 1000 m and more, the pressure in the stratum is P10 Mpa.

As the oil travels along the well path and the pipeline, the temperature and the pressure go down which results in extraction of the associated oil-dissolved gas,

increase of the oil viscosity and solidification of paraffins (high-molecular alkanes). Asphalt and paraffin deposits accumulate in the mouth of the well and on the inner surface of the pipes which hinders the oil transition. The research of the effects of the associated oil-dissolved gas or of its certain components on the thermophysical and transport properties of the highly viscous oil is a crucial problem for increasing the yield of the hardly recoverable oil.

Another circumstance calling for the research of the thermophysical properties of the paraffins is the prospects of their use as a thermal energy storage for the solar and hydrothermal power engineering. N-alkanes feature a high latent heat of the solid/liquid (liquid/solid) transition at a relatively constant temperature corresponding to the phase change temperature (Velez *et al.*, 2015a, b). Due to the latent heat of the phase change, n-alkanes can store from 5-14 times as much heat per unit volume (i.e., storage density) as accumulators based on such thermal media as water. At the same time, linear n-alkanes have an disadvantageous feature of a low value of the thermal conductivity  $\lambda$  compared to non-organic substances (Tarzimanov *et al.*, 1989, 1990, 1992, 1993, 1998, 1999; Gabitov, 1999; Tarzimanov and Gabitov, 1989, 2004) which may reduce the charging and discharging rate for the thermal energy storages during the melting and crystallization cycles. In order to develop the processes for the efficient heat accumulation and recovery and equipment designing employing such processes it is necessary to know the thermophysical properties at the phase change in a wide range of temperatures.

One of the prospective methods of the comprehensive measurement for the heat and temperature transfer, thermal activity and viscosity of gases, liquids, solid substances and their solutions including in the nearly critical range of the state is the transient hot wire method (Tarzimanov *et al.*, 1993; Gabitov, 1999; Tarzimanov and Gabitov, 2004).

As a part of this study, experimental thermal conductivity values  $\lambda$  have been obtained in the region of the solid/liquid phase change for  $C_{24}H_{50}$  (n-tetracosane) a representative of the n-alkanes at the atmospheric pressure and the temperature range of 312.85-325.16 k and temperature logs for mixtures of n-alkanes (paraffin) from  $C_{19}H_{40}$  (n-nonadecane) to  $C_{35}H_{72}$  (pentatriacontane) during melting (296.60-359.59 k) and crystallizing (317.25-349.45 k).

## MATERIALS AND METHODS

N-tetracosane ( $C_{24}H_{50}$ ) of Ch grade with the purity of not <99% for experiments to measure  $\lambda$  value. The sample of the n-tetracosane was used without any additional purification or removal of the dissolved water or air and no information on impurities was available. In order to obtain the thermal logs, a natural solid oil paraffin  $C_nH_{2n+2}$  was used which was a mixture of n-

alkanes from  $C_{19}H_{40}$  (n-nonadecane) to  $C_{35}H_{72}$  (pentatriacontane). According to the chromatography data, the maximum distribution corresponds to the homologue where  $n = 26$  (13%), the maximum content of the prevailing homologues ( $n = 24-28$ ) does not exceed 12-13% and the content of homologues where  $n < 22$  and  $n > 31$  does not exceed 5%. In order to check the adequacy of the method and the apparatus for measuring  $\lambda$  using the transient hot wire method, toluene  $C_7H_8$  of the CP (chemically pure) grade with the purity of not <99.9% was used. Polymethyl silicone liquid of PMS-200 grade was used as a thermostating liquid. Double-distilled water was applied for the temperature calibration of the measuring platinum wire.

The transient hot wire method is based on the ideal model of a linear heat source and the setting of the model due to the symmetry of the thermal field at  $t \geq 0$  is as follows:

$$\frac{\partial T'}{\partial \tau} = a \left( \frac{\partial^2 T'}{\partial r^2} + \frac{1}{r} \frac{\partial T'}{\partial r} \right) \quad (1)$$

Where:

$T'$  = The excessive wire Temperature

$t$  = The time

$r$  = The radial coordinate

$a$  = The temperature conductivity

Equation 1 is solvable under the following boundary conditions: at  $\tau = 0$ ,  $T' = 0$ ; at  $r \rightarrow \infty$ ,  $T' \rightarrow 0$ ; at  $r = r_0$ ,  $-2\pi r_0 \lambda (\partial T' / \partial r) = q_L$  where  $r_0$  is the wire radius,  $q_L$  is the constant heat flux per unit of the wire length. If Eq. 1 is solved relative to the temperature of the linear heat source (Carslaw and Jaeger, 1964):

$$T' = (q_L / 4\pi\lambda) \cdot \ln \left( 4a\pi^2 / r_0^2 C \right) \quad (2)$$

for 2 instances of time with a sufficient accuracy degree, we obtain the dependency to determine the heat conductivity of the liquid in which the heat source (wire) is submerged:

$$\lambda = \frac{q_L}{4\pi} \cdot \frac{\ln(\tau_2 / \tau_1)}{T_2 - T_1} \quad (3)$$

Equation 2,  $C = 1,781 (\ln C = 0.577, \dots, \text{-Euler's constant})$ . The Eq. 2 includes the temperature conductivity which evidences the possibility of determination of a (Tarzimanov *et al.*, 2002). If a linear or a flat heat source is placed in a flow of liquid or gas then the transient hot wire method enables to simultaneously measure  $\lambda$ ,  $a$ , thermal activity  $\chi$  and kinetic viscosity  $\nu$  of the liquid or gas (Gabitov, 1999; Tarzimanov and Gabitov, 2004).

The experimental assembly implementing the transient hot wire method is shown in Fig. 1. The experimental assembly is similar to those used in our laboratory to measure  $\lambda$  in several groups of liquids and

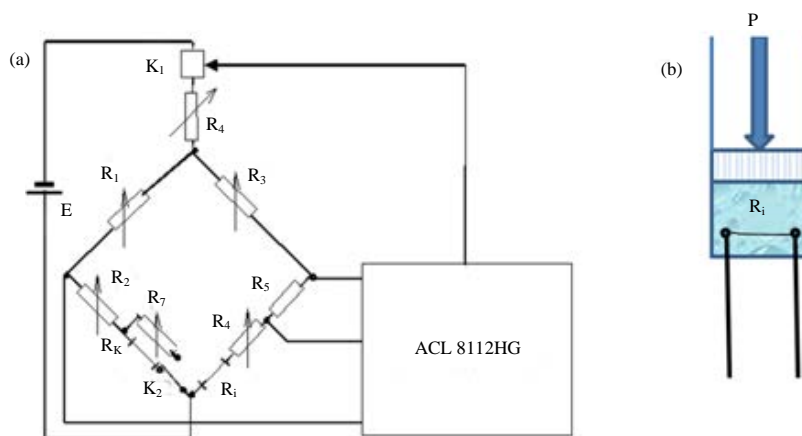

Fig. 1: Diagram of the experimental assembly to measure the heat conductivity and the temperature conductivity a) Diagram of placing the platinum wire (measuring probe)  $R_i$  in the measuring cell; b) E is the direct current source, K1 is the optron-transistor switch, R1-R7 are the low-induction resistor banks, K2 is the switch to switch from the measuring mode  $\lambda$  to the measuring mode, a  $R_K$  is the compensatory probe, ACL 8112HG is a multifunction adaptor to collect the data with the programmable amplification factor combined with the computer

gases (Tarzimanov *et al.*, 1989, 1990, 1992, 1993, 1998, 1999; Gabitov, 1999; Tarzimanov and Gabitov, 2004; Tarzimanov and Gabitov, 1989; Carslaw and Jaeger, 1964; Tarzimanov *et al.*, 2002). As the details of the experimental assembly and the measurement principles have been described previously (Tarzimanov and Gabitov, 1989; Tarzimanov *et al.*, 1989, 1990, 1992, 1998, 1999, 2002; Carslaw and Jaeger, 1964), certain insignificant changes will be noted. In order to measure  $\lambda$ , a horizontally placed platinum wire with the diameter of  $4 \pm 0.01 \mu\text{m}$  and the length of  $33 \pm 0.05 \text{ mm}$  was used. The two ends of the wire were soldered with gold to platinum leads with the diameter of 1 mm. The leads were fixed on the bottom of the body of the measuring cell made of polyethylene. The platinum wire  $R_i$  (Fig. 1) served simultaneously as a heat source and a resistance thermometer. The ends of the platinum wire  $R_i$  were supplied with direct current pulses with the duration of 0.2-0.5 sec at which the overheating of the measuring probe amounted to 0.2-0.5 k. During the pulse, 224 V values were measured at the ends of the probe with the equal pitch depending on  $\ln \tau$ . The interval between the pulses amounted to 2-3 min, so that, the heat from the previous pulse could dissipate in the environment before the supply of the next heating pulse. The current pulse was generated with the optron-transistor switch k1 controlled with the multifunctional adaptor for the data collection with the programmable amplification factor ACL 8112 HG by ADLINK technology firm combined with a computer.

Prior to the main experiments to measure the heat conductivity, the calibration of the platinum wire was done using the reference platinum resistance thermometer

PTS-10. Toluene was poured to the measuring cell with the platinum wire and the reference platinum resistance thermometer. The measuring cell was placed in a glass cylindrical vessel with melting ice of double-distilled water. The glass cylindrical vessel was in a liquid-based thermostat M01M by TERMEX firm with the thermostating liquid PMS-200. The calibration was performed to the melting point of  $\text{H}_2\text{O}$  ( $0^\circ\text{C}$ ) to its boiling ( $100^\circ\text{C}$ ) with the step of  $10^\circ\text{P}$ . Further, a graph was plotted for the dependence of the resistance of the platinum wire  $R_t, \Omega$  by the temperature  $t^\circ\text{C}$ . The factors  $A = 0.38617 \cdot 10^{-2}$  and  $B = -0.539 \cdot 10^{-6}$  were determined with the least square method in the equation:

$$R_t = R_0(1 + At + Bt^2) \quad (4)$$

where,  $R_0 = 185.64 \Omega$  is the resistance of the platinum wire at  $0^\circ\text{C}$  Obtained during the calibration.

Values of the factors A and B in the (Eq. 4) were introduced in the software on the computer combined with ACL 8112HG (Fig. 1). Upon completion of all experiments to measure  $\lambda$  of n-tetracosane and paraffin, another calibration of the platinum wire was performed. In order to ensure obtaining adequate results for measuring  $\lambda$  using the transient hot wire method, a range of reference measurements was performed for  $\lambda$  of toluene at various temperatures at the beginning and the end of the experiments with n-tetracosane and paraffin. The measurements were performed with the values of  $\lambda$  for toluene known from the literature.

A sample of n-tetracosane and paraffin melted first then it was poured to the polyethylene cylindrical cell. The cell had the inner diameter of 40 mm. The filling level of the sample was 20 mm, so that, the platinum wire was in the middle of the layer of the substance in question. To obtain the solid n-tetracosane or paraffin without any air layers, a piston of polyethylene was placed over the layer of the sample. The absence of air between the sample of the substance in question and the piston was ensured. A slow cooling of the melted sample was carried out under the pressure of the piston. The excessive pressure inside the sample amounted to approximately 0.1 Mpa. The cell with the sample was cooled with the air of the ambient temperature. After the solidification of the sample, the pressure on the piston was removed and the substances under examination remained at the atmospheric pressure. When the electric current runs through the wire, its temperature increased due to Joule heat. The wire heating rate depends mostly on  $\lambda$  of n-tetracosane or paraffin contacting the wire. As a result of the temperature increase, the electric resistance of the material (platinum) of the wire grows as well as the voltage difference at the ends of the wire. A graph of the dependence  $T' = f(\ln t)$  is plotted for each heating cycle. Then, the dependence is linearized using the least square method and angle  $\varphi$  is determined between the inclination of the line and the axis  $\ln t$ . After that having written the (Eq. 3) as follows:

$$\lambda = \frac{q_l}{4\pi} \cdot \frac{1}{\operatorname{tg}\varphi'} \quad (5)$$

$\lambda$  was determined. Equation 5 is true for an infinitely long linear heat source. Although, the actual heat source virtually coincides with the model as the ratio of the wire length relative to its diameter amounted to  $>8000$ , certain adjustments have to be introduced. Therefore, the following adjustments were introduced to account for the deviation from the ideal: for the effect of the heat inertia of the wire for the heat irradiation from the surface of the wire for alteration of the wire length along with the temperature for the heat leakage from the ends of the wire. The adjustments were introduced on the dependences described by (Gorshkov and Umansky, 1982). The total of all the adjustments introduced did not exceed 2%.

## RESULTS AND DISCUSSION

Figure 2 demonstrates the comparison of the paraffin and n-tetracosane temperature change depending on the

time at melting. When the transition from the solid state to the liquid state occurs, a stepwise variation of the temperature of n-tetracosane takes place.

In case of a mixture-a paraffin-a smooth variation of the temperature occurs during the phase change. Obviously in case of the paraffin, a successive transition of the components of n-alkanes from  $C_{19}H_{40}$  (n-nonadecane) to  $C_{35}H_{72}$  (pentatriacontane) from the solid state to the liquid state takes place.

Figure 3 shows that  $\lambda$  of n-tetracosane in the liquid phase tends to reduce along with the temperature increase. The heat conductivity of n-tetracosane was researched by many researchers using various methods (Vargaftik *et al.*, 1994) and the values of  $\lambda$  obtained in this study coincide with such results within 1%.

The ambiguity of the values of  $\lambda$  in the liquid phase obtained in this study does not exceed 1%. No comparison can be done for the solid phase due to virtually complete absence of the data in the literature. N-alkanes form a scaly structure during solidification (Kotelnikova and Filatov, 2002) unless special measures are taken, i.e., solid particles of the substance interchange with an air gap. Due to the above, it is impossible to ensure a close contact of the heat source (the measuring wire in our case) with the medium under study. Another adverse circumstance affecting the accuracy of measuring  $\lambda$  of solid n-alkanes is related to a significant alteration of their density (Kotelnikova and Filatov, 2002). Such factor also results in a loss of contact between the heat source and the solid n-alkane due to a shrinkage of the latter. As a result, a systematic error occurs resulting in an intense understatement of the  $\lambda$  values. Thus, a failure to account for such factors in the study (Tarzimanov *et al.*, 1992) resulted in obtaining understated values of  $\lambda$ . In this study in order to ensure a close contact of the measuring wire with the solid n-tetracosane, the solidification of the latter was carried out under a pressure of the piston (Fig. 1 b). Measuring of  $\lambda$  of n-tetracosane and metering of the thermographs for the melting of the paraffin and n-tetracosane took place at the atmospheric pressure, i.e., the pressure was lifted from the piston.

Figure 1 evidences that there is a significant (2-3%) scattering of the experimental values for n-tetracosane in the solid state. Such scattering should obviously be attributed to an insufficiently close contact of the measuring wire with the substance under study. The uncertainty of measuring  $\lambda$  for n-tetracosane is estimated as 3.8%. As noted in (Kotelnikova and Filatov, 2002) the thermal X-ray study of the phase change of n-alkanes, a reduction of the temperature pitch to decimals of the degree turned out to be crucial. The thermal X-ray experiment proved that an

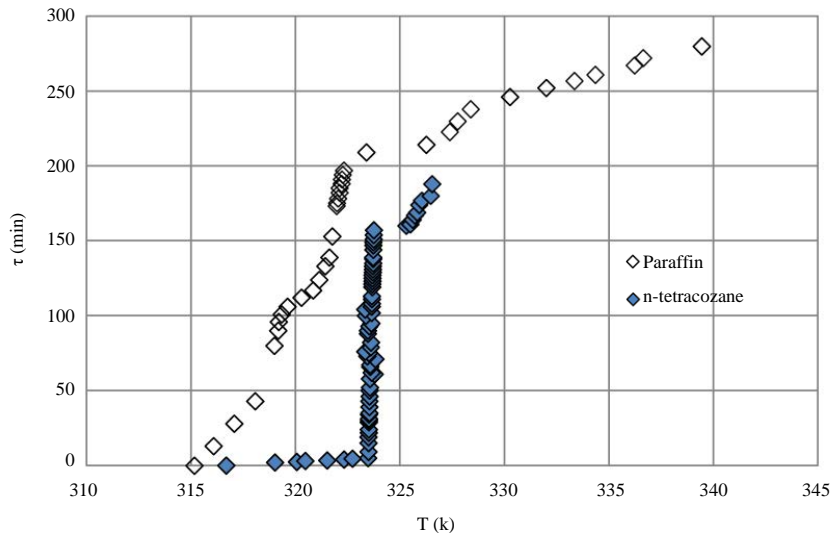

Fig. 2: Comparison of thermographs of paraffin and n-tetracozane during melting

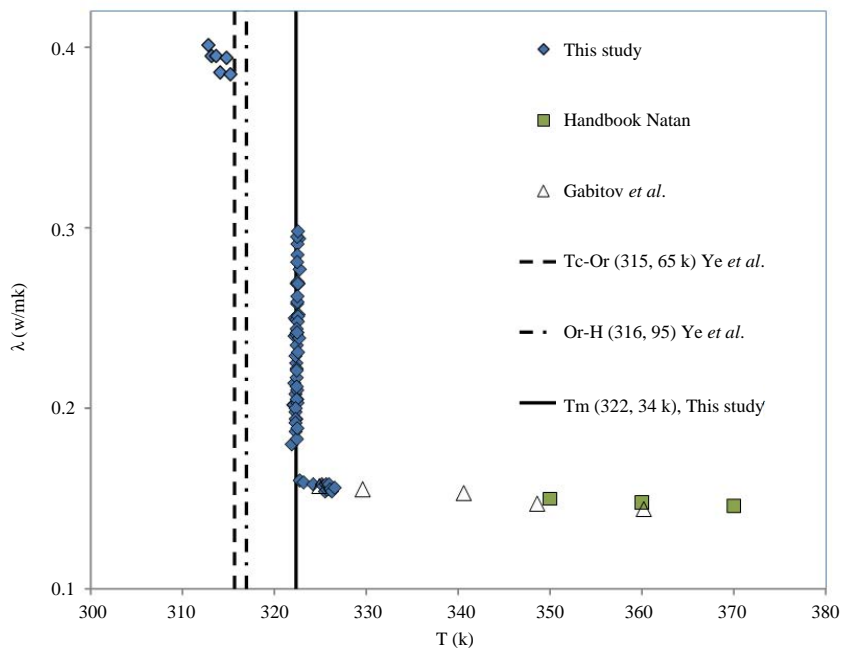

Fig. 3: Dependency of the heat conductivity of n-tetracozane on the temperature during melting

increase of such pitch by as little as an order of magnitude, i.e., to 2-5°C may result in a miss of qualitatively critical changes in the diffraction pattern. This may be the reason why in (Kotelnikova and Filatov, 2002) in the initial stage of the study and other researches missed the transition of n-tetracozane to the low-temperature orthorhombic rotary-crystal state during their experiments. In the course of heating, the phase change of n-tetracozane includes two transitions: solid state/solid state and solid state/liquid state. The first

transition is the triclinic-orthorhombic change (referred to as Tc-Or in Fig. 3). According to (Kotelnikova and Filatov, 2002) it occurs at 315.65 k. The second transition is the orthorhombic-hexagonal change (referred to as Or-H in Fig. 3 at 316.19 k while the third transition is from the hexagonal crystal phase (low-temperature orthorhombic rotary-crystal) to the liquid state (referred to as Tm in Fig. 3) which takes place at 322.35 k (Kotelnikova and Filatov, 2002). During our experiments, the cooling rate in the thermostat was

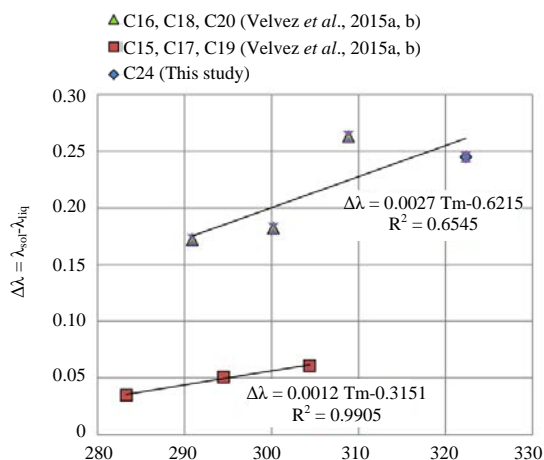

Fig. 4: Heat conductivity variation during the solid liquid phase change for odd-numbered and even-numbered homologues of n-alkanes

$0.2 \text{ km}^{-1}$ . We determined the temperature of the third transition experimentally which amounted to  $T_m = 322.34 \text{ k}$  (Fig. 3). The value  $T_m$  was determined as the average of the initial melting temperature of n-tetracozane of  $321.9 \text{ k}$  and the melting end temperature of  $322.77 \text{ k}$  in which case  $\lambda$  is reduced from  $0.294 \text{ Wm}^{-1}$  to  $0.16 \text{ Wm}^{-1}$ . The heat conductivity of the mix of the solid and the liquid n-tetracozane was measured in the stated temperature interval. Apparently, there is a good coincidence of the value  $T_m$  with the result obtained in (Kotelnikova and Filatov, 2002).

Figure 3 shows that experimental values of  $\lambda$  for n-tetracozane are missing in the temperature range of  $315.3\text{-}321.9 \text{ k}$ . It is due to the impossibility to determine a linear section in the dependency graphs  $T' = f(\ln\tau)$  at the said temperature range. It is probably related to the thermal agitation in the substance under study due to the transformation of the lattice in the solid state.

Even-numbered ( $2n$ ) and odd-numbered ( $2n-1$ ) homologues of n-alkanes ( $\text{C}_n\text{H}_{2n+2}$ ) have molecules of a different symmetry and therefore as a rule have a different crystalline structure. Due to the above, their physical (and thermophysical) properties change according to their own laws in the course of transition from one homologue to another. Figure 4 demonstrates a variation of the heat conductivity in the course of transition from the solid state to the liquid state in the range of homologues of n-alkanes where a difference can be traced in the trends of alteration of  $\Delta\lambda$  for even-numbered and odd-numbered homologues. When determining  $\Delta\lambda$ , the temperature range is encompassed from the transitions of the solid state/solid state to  $T_m$ . The deviation of the value  $\Delta\lambda = 0.241 \text{ Wm}^{-1}$  we obtained for n-tetracozane from the generalizing dependency  $\Delta\lambda = 0.0027 T_m - 0.6215$  even-numbered n-alkanes does not exceed 0.6% which may evidence the fidelity for the values of  $\lambda$  obtained in this study including those in the solid state.

## CONCLUSION

When the phase changes from solid to liquid, a surge can be observed in the values of the heat conductivity factor. Thus, the heat conductivity of n-tetracozane is reduced step-wise from  $0.401\text{-}0.16 \text{ Wm}^{-1}$  as the temperature changes from  $312.85\text{-}322.77 \text{ k}$ . In case of a mix-the paraffin, a smooth change of the thermograph is observed during the phase change.

## ACKNOWLEDGEMENTS

The study was performed with the financial support of the Ministry of Science and Education of the Russian Federation as a part of the Public Assignment 13.5112.2017/8.9 and the RSF agreement 18-19-00478.

## REFERENCES

- Carslaw, H.S. and J.C. Jaeger, 1964. Thermal Conductivity of Solids Bodies. Nauka Publishing House, Moscow, Russia, Pages: 488.
- Gabitov, F.R., 1999. Application of the pulse heating method for measuring thermophysical properties of liquids in a flow. J. Kazan Technol. Univ., 1: 61-68.
- Gorshkov, Y.A. and A.S. Umansky, 1982. Measuring of Heat Conductivity of Gases. Energoatomizdat Publisher, Moscow, Russia, Pages: 223.
- Kotelnikova, Y.N. and S.K. Filatov, 2002. [Crystal Chemistry of Paraffins: Methods, Researches, Results, Behavior in Nature]. Zhurnal Neva, Saint-Petersburg, Russian, ISBN: 5-87516-238-4, Pages: 352 [in Russian].
- Tarzimanov, A.A. and F.R. Gabitov, 1989. Molecular thermal conductivity of heavy-water vapor at pressures up to 30 MPa and temperatures up to  $700^\circ \text{C}$ . J. Eng. Phys. Thermophys., 56: 73-77.
- Tarzimanov, A.A. and F.R. Gabitov, 2004. An investigation of the thermophysical properties of a liquid in a flow using the method of pulse heating. High Temp., 42: 231-237.
- Tarzimanov, A.A., F.D. Yuzmukhametov, F.R. Gabitov, R.A. Sharafutdinov and N.Z. Shakirov, 2002. Thermal conductivity and thermal diffusivity of liquid aromatic hydrocarbons undistorted by radiation heat transfer. High Temp., 40: 524-530.
- Tarzimanov, A.A., F.R. Gabitov and I.N. Ponikarova, 1998. Thermal conductivity of various organic liquids at high temperatures. High Temp., 36: 495-496.
- Tarzimanov, A.A., F.R. Gabitov and I.N. Ponikarova, 1999. High-temperature thermal conductivity of various organic liquids. Russ. J. Applied Chem., 72: 340-342.
- Tarzimanov, A.A., F.R. Gabitov, F.D. Usemukhametov and R.A. Sharafutdinov, 1993. Estimation of the radiant component of the thermal conductivity of liquids at high temperatures. High Temp. High Pressures, 25: 67-70.

- Tarzimanov, A.A., F.R. Gabitov, I.N. Ponikarova and F.D. Yuzmukhametov, 1992. Application of pulse heating method for various thermal studies. *J. Eng. Phys. Thermophys.*, 63: 1004-1008.
- Tarzimanov, A.A., R.A. Sharafutdinov and F.R. Gabitov, 1989. Implementation of the pulse heating method for measuring the molecular heat conductivity of liquids and compressed gases. *Metrology*, 1: 29-34.
- Tarzimanov, A.A., R.A. Sharafutdinov and F.R. Gabitov, 1990. Thermal conductivity of n-alkanes and 1-alkenes not distorted by radiative energy transfer. I. Experimental results. *Mag. Eng. Phys.*, 59: 662-667.
- Vargaftik, N.B., L.P. Filippov, A.A. Tarzimanov and E.E. Totkii, 1994. *Handbook of Thermal Conductivity of Liquids and Gases*. CRC Press, London, UK.,.
- Velez, C., J.M.O. de Zarate and M. Khayet, 2015a. Thermal properties of n-pentadecane, n-heptadecane and n-nonadecane in the solid/liquid phase change region. *Int. J. Thermal Sci.*, 94: 139-146.
- Velez, C., M. Khayet and J.M.O. de Zarate, 2015b. Temperature-dependent thermal properties of solid/liquid phase change even-numbered n-alkanes: N-Hexadecane, n-octadecane and n-eicosane. *Applied Energy*, 143: 383-394.