

A Computational Method to Determine the Optimum Parameters of a Controller Designed for Mathematically Modeled Systems

¹M.E. Guven, ²A. Altintas

¹Faculty of Technical Education, Gazi University, Ankara, Turkey

²Faculty of Technical Education, Dumlupinar University, Simav/Kütahya, Turkey

Abstract: A control system consists of an interconnection of components so that the output of the overall system will follow as closely as possible the desired signal. Many industrial automatic controllers are electronic, hydraulic, pneumatic, or their combinations. Industrial controllers, also, may be classified according to control actions. Generally there are four basic control actions: on-off control, Proportional (P) control, Integral (I) control and Derivative (D) control. The performance of a controlled physical system can often be improved by fine adjustment or tuning the control actions. If a mathematical model of the plant can be derived, the fine-tuning of the controller parameters can be performed by computer simulations. In this study, a new computational method to determine the optimum parameters of a controller for mathematically modeled system is developed. The method, a kind of the trial-and-error approach to system design, computes the optimum parameters of a controller (P, PI, PD and PID) in a short time by using mathematical model of the system and design specifications of the controller. For this purpose, a computer simulation program has been improved and tested.

Key words: Control techniques, fine tuning of P-I-D controllers, system modeling

INTRODUCTION

Modeling is an extremely important problem because the success of the design depends on whether or not physical system is adequately modeled. A basic prerequisite to the development of almost all strategies for control is the ability to obtain mathematical model for the plant. The mathematical model must accurately reflect the static and dynamic performance characteristics of a dynamic system^[1,2]. System models are generally described in terms of variables that are only indirectly related to power and energy. The required model is formulated as a set of differential equations. Differential equations models can be transformed using the Laplace transformation or phasor algebra to obtain algebraic functions in terms of complex variables. The transformations provide transfer-function models and there are many analysis and design techniques that employ the algebraic models. An alternative format for control system models is the state-space model. The state-space model is a time-domain model with a formulation that is particularly convenient for digital simulation. This model type is the basis for a number of analysis and design techniques that are sometimes described as modern control theory. Both the transfer-function model and the state-space model are a linear system technique.

Many industrial automatic controllers are electronic, hydraulic, pneumatic, or their combinations. An automatic controller compares the actual value of the plant output with the reference input, determines the deviation and produces a control signals that will reduce the deviation to zero or to a small value. The manner in which the automatic controller produces the control signal is called the control action. There are four basic control actions used in industrial applications: on-off control, Proportional (P) control, Integral (I) control and Derivative (D) control. Sometimes it is necessary to combine control actions. So, there are also some combinational control actions consisting of P, I and D control actions: Proportional-plus-Integral (PI) control, Proportional-plus-Derivative (PD) control and Proportional-plus-Integral-plus-Derivative (PID) control^[2,3].

Because most PID controllers are adjusted on site, many different types of tuning rules have been proposed in the literature^[4-10]. Using these tuning rules, delicate and fine-tuning of PID controllers can be made on site. If the plant is so complicated that its mathematical model can not be easily obtained, then analytical approach to design of a P-I-D controller is not possible. Then we must resort to experimental approaches to the tuning of P-I-D controllers, such as Ziegler-Nichols tuning method^[11]. However, if a mathematical model of the plant can be derived, then it is possible to apply various design

techniques (such as root-locus method) for determining parameters of the controller that will meet the transient and steady-state specifications of the closed-loop system^[12-14]. In this study, a computational method to determine optimum parameters of a controller for modeled systems is introduced. In the method which is a kind of the trial-and-error approach to system design, we set up a mathematical model of the control system and plant and adjust the optimum controller parameters until the design specifications are attained. To obtain all cases verifying design specifications and to determine the optimum parameters, a computer program package is developed. The computer program is improved with Matlab package program containing control system toolbox.

The effects of control actions on system performance: The simplest control action is the proportional control. This type control action speeds up the system performance to some extent. The proportional control provides a control signal that is proportional to error. The proportional controller is essentially an amplifier with an adjustable gain K_p . However, a substantial increase in gain K_p leads to a deterioration of stability.

In the proportional control of a plant whose transfer function does not possess an integrator $1/s$, there is a steady-state error, or offset in the response to a step input. Such an offset can be eliminated if the integral control action is included in the controller. Integral control action, while removing offset or steady-state error may lead to oscillatory response of slowly decreasing amplitude or even increasing amplitude, both of which usually undesirable.

Derivative control action, when added to a proportional control, provides high sensitivity. An advantage of using derivative control action is that it responds to the rate of change of the actuating error and can produce a significant correction before the magnitude of the actuating error becomes too large. Derivative control thus anticipates the actuating error, initiates an early corrective action and tends to increase the stability of the system. Although derivative control does not effect the steady-state error directly, it adds damping to the system and thus permits the use of a large value of the gain K_p , which will result in an improvement in the steady-state accuracy. Derivative control is never used alone because it operates on the rate of change of the actuating error not the actuating error itself. It is always used in combination with proportional or proportional-plus-integral control action^[1,12,15].

Performance criterions: In general, the performance of control systems is divided into two parts: the steady-state

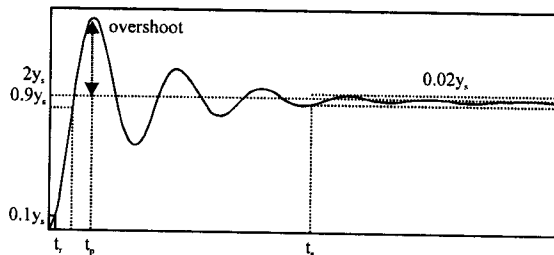

Fig. 1: Transient performance criterions

performance, which specifies accuracy and transient performance, which specifies the speed of response. These performances are defined with respect to test signals. The test signals used in design are the impulse function, the step function, the ramp function and the parabolic function.

In many practical cases, the desired performance characteristics of control systems are specified in terms of time domain quantities. The steady-state performance is concerned with the response of $y(t)$ as t (time) approaches infinity. It is defined for step, ramp and parabolic inputs. Transient performance is concerned with the speed of response or the speed at which the system reaches the steady-state. Although the steady-state performance is defined for a step, ramp or parabolic reference input; the transient performance is defined only for a step reference input. The transient response of a practical control system often exhibits damped oscillations before reaching steady-state. The transient performance is generally specified in terms of the rise time t_r , settling time t_s , peak time t_p and maximum overshoot M_p (Fig. 1). The rise time can be defined in many ways; we shall define it, as the time required for the response to rise from 10 to 90% of its steady-state value. The settling time is the smallest time for the response to reach and remain inside $\pm 2\%$ of its steady-state value. The peak time is the time required for the response to reach the first peak of the overshoot. Maximum overshoot is the maximum peak value of the response curve measured from unity. It should be known that the maximum overshoot and rise time conflict with each other. In other words, both the maximum overshoot and rise time can not be made smaller simultaneously. If one of them is made smaller, the other necessarily becomes larger^[1,3].

The time-domain specifications just given above are quite important because most control systems are time-domain systems; that is, they must exhibit acceptable time responses. This means that the control system must be modified until the transient response is satisfactory.

MATERIALS AND METHODS

To determine optimum parameters of a controller, a computer program improved in Matlab software package is developed. Matlab is a widely used engineering software package that provides a powerful and friendly environment for engineering computation and simulation.

The Matlab software package with the control system toolbox is an efficient computational resource that can significantly enhance the study and application of control engineering. The programming tools encompass both basic mathematical operations and a large set of computational procedures that are designed for specific tasks. Thus, the user has the option of developing a customized program or calling any of the special-purpose functions that reside in Matlab files^[16-18].

The program checks the overall system whether all performance specifications have been met. If the designed control system does not meet the performance specifications, then repeat the design procedure by changing the controller parameters until all specifications are met. Simplified flowchart of the developed computer program is given in Fig. 2. In according to this scheme, after defining transfer function of the modeled system, the step responses of all control types are displayed in 3D space individually at a certain range. After selecting controller type and design specifications, transient performance of the overall system is calculated roughly for all cases step by step and is collected at a matrix form (unstable conditions are not taken into consideration).

Then, the calculation results consisting of rise time, settling time, overshoot percentage and etc. are displayed in 3D space and are printed in a file for P, PI and PD controllers. For PID controller, the results are printed only in a file numerically because of having four-dimension. The next step is to determine optimum controller parameters by rearranging the results. After obtaining the optimum parameters, step response of the overall system is displayed in time-domain. If the step response is not acceptable, repeat the calculation procedure again by changing the range and step size.

An exemplary application: The armature-controlled permanent-magnet DC motor is a type of motor that is commonly used for control system applications. The operation of DC motor with armature control provides a nearly linear ratio of steady-state velocity to input voltage over a speed range that extends from zero to the maximum rated angular velocity^[19,20]. Voltage control of an armature-controlled DC motor provides an innate feedback system, as shown in Fig. 3. If the load on the motor increases due to an increase in viscous friction, the steady-state angular velocity of the motor will decrease. However, if the angular velocity is reduced, the back emf is also reduced. With voltage control, this change produces an increase in the armature current, thereby increasing the developed torque. Thus, the motor exhibits an automatic feedback compensation that tends to maintain a constant angular velocity. The overall transfer function relating angular velocity to input voltage is given in Eq. 1.

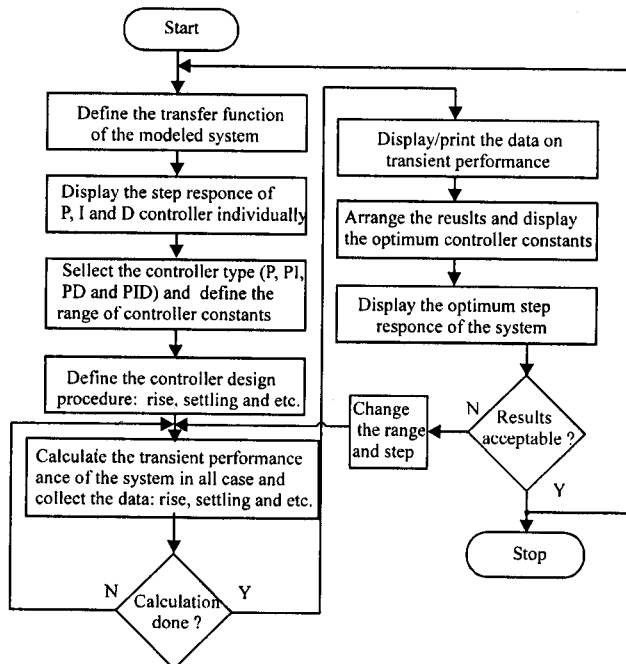

Fig. 2: Simplified flowchart of the developed computer program

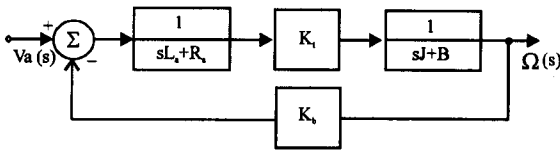

Fig. 3: Block diagram of the DC motor

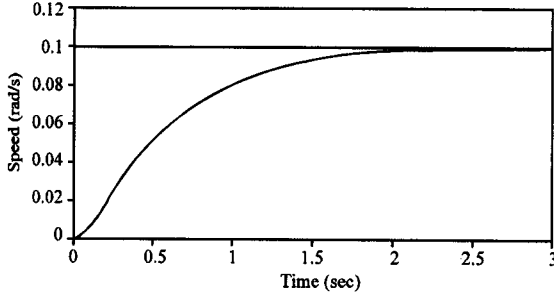

Fig. 4: Step response of the uncontrolled DC motor

Where the parameters are: the armature resistance R_a in ohms; the armature inductance L_a in henrys; the induced emf constant K_b in volt/(rad/sec); the torque constant K_t in N-m/Amp; the moment of inertia J in kg-m²; the viscous friction coefficient B in N-m/(rad/sec).

$$\frac{\Omega(s)}{V_a(s)} = \frac{K_t}{L_a J s^2 + (R_a J + L_a B) s + (R_a B + K_t K_b)} \quad (1)$$

Let the DC motor has those parameters: $R_a = 1\Omega$, $L_a = 0.5$ H, $K_t = K_b = 0.01$, $J = 0.01$ kg m², $B = 0.1$ N-m/(rad/sec). Open-loop step response of the uncontrolled DC motor is given in Fig. 4. From the Fig. 4 we see that the motor can only rotate at 0.1 rad/sec with an input voltage of 1 Volt. Also, it takes the motor 3 sec to reach its steady-state speed. Another matter is the steady-state error of 90%.

Control systems are designed to perform specific tasks. They generally related to accuracy, relative stability and speed of response. For routine design problems, the performance specifications may be given in terms of precise numerical values. The most important part of control system design is to state the performance specifications precisely so that they will yield an optimal system for the given purpose. So, the problem is to design an optimum PI controller for motor to meet the following specifications (it is assumed that the overall system has unity feedback configuration and a step input of 1 rad/sec):

- Steady-state (position) error = 0
- Overshoot percentage $\leq 5\%$

- Steady-state time ≤ 5 sec
- Settling time ≤ 3 sec
- Rise time as small as possible

After running the program and defining the transfer function of DC motor, (Fig. 5, 6 and 7). These figures individually show the step response of P-I-D control of DC motor in 3D space respectively, where K_p , K_i and K_d are in the range 0-300. As can be seen from Fig. 5; just as K_p values, larger than a certain value, increase continuously so does the overshoot; but, rise time and steady-state error decrease inversely.

As in Fig. 6, K_i values, larger than a certain value, cause unstable cases; but, eliminates the steady-state error to some extent. As in Fig. 7, just as K_d values increase continuously so does the transient performance. After selecting the controller type and defining the design specifications, the program calculates transient performance of the overall system for all cases and collects the data such as rise time, overshoot %, settling time, steady-state error and etc.; then, displays the collected data graphically in 3D space or numerically in a file (Fig. 8 and 9). The numerical results, given in Fig. 9, verify the correctness of solution.

After arranging the data, the program obtains optimum parameters of the selected controller type and displays the step response of overall system. Firstly, the program calculates the controller parameters as an integer value; if the resultant step response is not acceptable, then calculation procedures repeat again for decimal fraction by changing the range and step size. As a result, optimum PI-controller parameters calculated for given specifications are $K_p = 53.88$, $K_i = 41.51$. The unit step response of PI-controlled DC motor with optimum controller parameters is given in Fig. 10.

CONCLUSIONS

When a new system is planned and developed, or a control strategy and a drive system are formulated, it is often convenient to study the system performance by simulation before building the breadboard or prototype. The simulation not only validates the system performance, but also permits optimization of the system performance by iteration of its parameters. Thus, valuable time saved in the development and design of a product and the failure of components of poorly designed system can be avoided. This study deals with determining the optimum parameter of a controller for modeled system by using a computer simulation program developed for this purpose. The program generates optimum parameters of

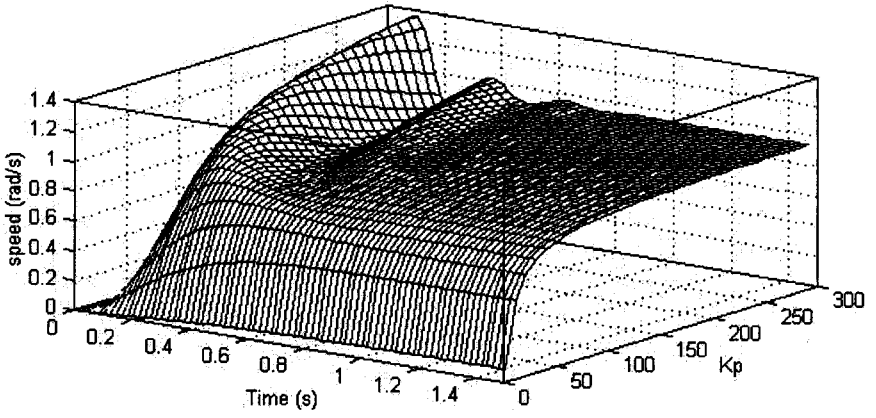

Fig. 5: The step-response surface of P-control of DC motor

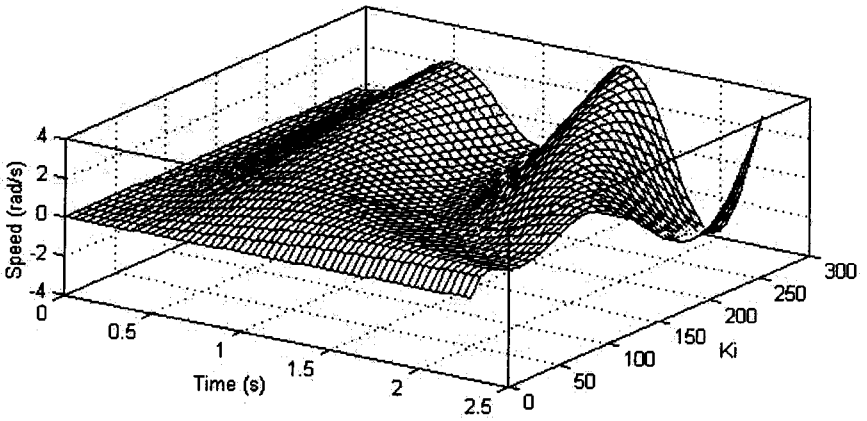

Fig. 6: The step-response surface of I-control of DC motor

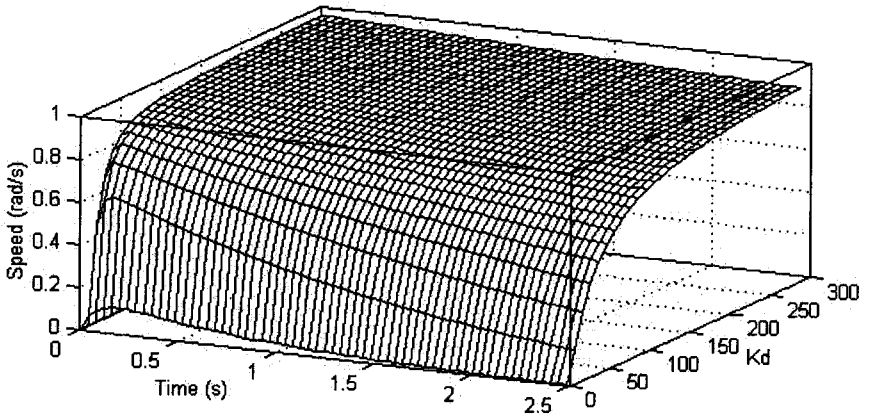

Fig. 7: The step-response surface of D-control of DC motor

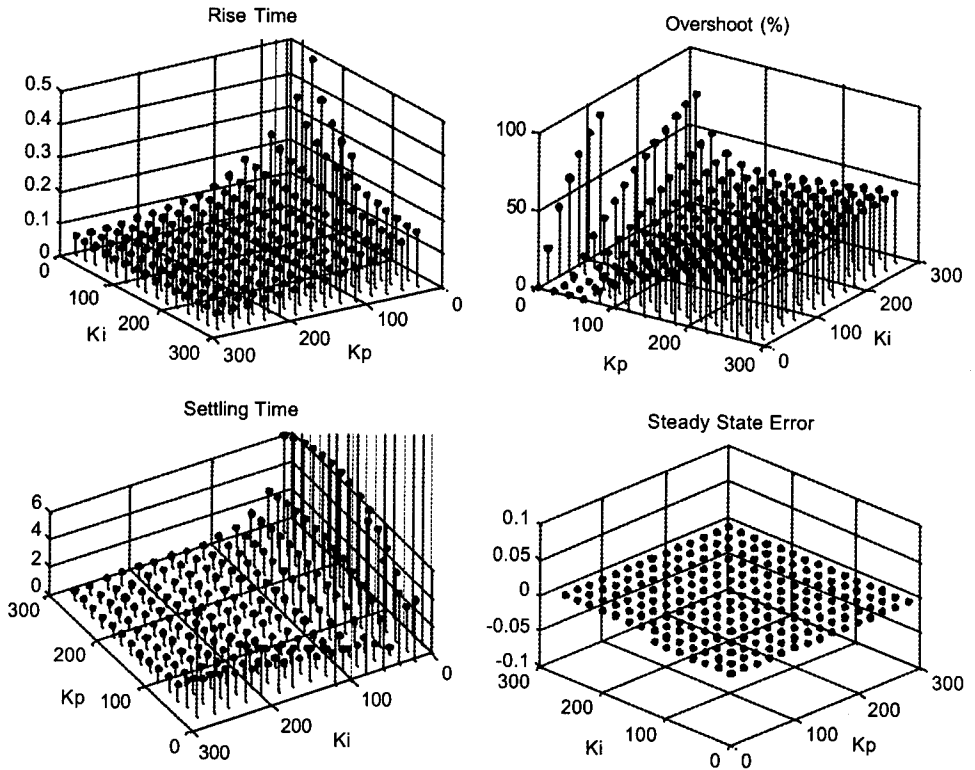

Fig. 8: Transient performance of PI-control of DC motor

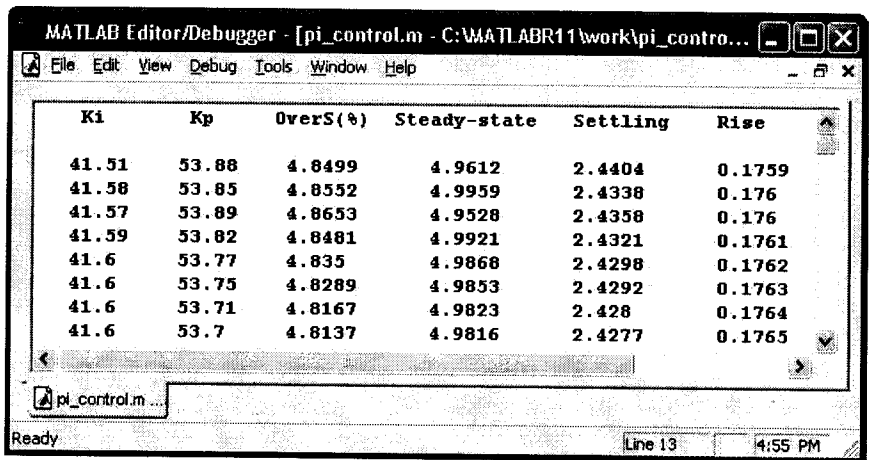

Fig. 9: Numerical results of transient performance of PI-controlled DC motor

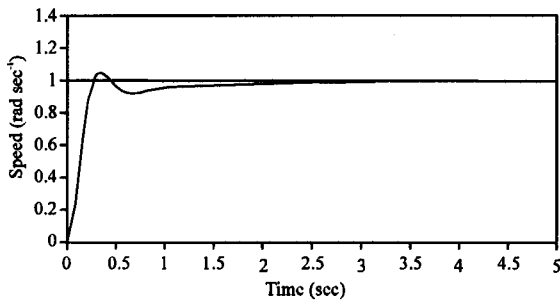

Fig. 10: Step response of DC motor with optimum PI-controller parameters for given specifications

the selected controller type and displays optimum step response of the overall system by using modeled system and transient performance criterions. The program spends a few minutes to calculate controller parameters corresponding to system model and controller type; naturally PID controller takes the longest time.

REFERENCES

1. Dorny, C.N., 1993. *Understanding Dynamic Systems: Approaches to Modeling Analysis and Design*. Prentice Hall, Englewood Cliffs, NJ.
2. Katsuhiko, O., 1997. *Modern Control Engineering*, 3rd (Edn.). Prentice-Hall International Editions, Upper Saddle River, New Jersey.
3. Chi-Tsong, C., 1987. *Control System Design, Conventional, Algebraic and Optimal Methods*. Pond Woods Press, NY.
4. Olivier, L., G. Michel, M. Magnus, B. Emmanuel and T. Lionel, 2003. Iterative feedback tuning of PID parameters: Comparison with classical tuning rules. *Control Engineering Practice*, 11: 1023-1033.
5. Chidambaram, M. and R.P. Sree, 2003. A simple method of tuning PID controllers for integrator/dead-time processes. *Computers and Chemical Engineering*, 27: 211-215.
6. Ching-Hung, L. and T. Ching-Cheng, 2000. Tuning of PID controllers for unstable processes based on gain and phase margin specifications: A fuzzy neural approach. *Fuzzy Sets and Systems*, 128: 95-106
7. Li, J., Y. Kang and J. Chen, 2000. Fuzzy-tuning PID control of an inverter with rectifier-type nonlinear loads. *Power Electronics and Motion Control Conference, Proceedings PIEMC*, 1: 381-384
8. Cominos, P. and N. Munro, 2002. PID controllers: Recent tuning methods and design to specification. *Control Theory and Applications, IEE Proceedings*, 149: 46-53
9. Shimizu, K. and K. Honjo, 2002. PID controller tuning via quasi pole assignment method. *Control Applications. Proceedings of the 2002 International Conference*, 1: 253-259.
10. Kaya, I., 2004. IMC based automatic tuning method for PID controllers in a Smith predictor configurations. *Computers and Chemical Engineering*, 28: 281-290.
11. Åström, K.J. and T. Häggglund, 2004. Revisiting the Ziegler-Nichols step response method for PID control. *J. Process Control*, 14: 635-650.
12. Lewis, P.H. and C. Yang, 1997. *Basic Control Systems Engineering*. Prentice Hall Inc., Upper Saddle River, New Jersey.
13. Yüksel, İ., 1997. Otomatik kontrol sistem dinamiği ve Denetim Sistemleri. Uludağ Üniversitesi, Bursa.
14. Charles, L.P. and H. T. Nagle, 1995. *Digital Control System and Design*, 3rd (Edn.). Prentice-Hall Inc., Englewood Cliffs, New Jersey.
15. Katsuhiko, O., 1995. *Designing Linear Control System with Matlab*. Prentice-Hall, Englewood Cliffs, New Jersey.
16. Biran, A. and M. Breiner, 1995. *MATLAB for Engineers*. Addison-Wesley Publishing Company.
17. Yüksel, İ., 2000. Matlab ile Mühendislik Sistemlerinin Analizi ve Çözümü, Vipaş A.Ş, Uludağ Üniversitesi, Bursa.
18. MATLAB® for Microsoft Windows, MathSoft Inc., 1999.
19. Kazmierkowski, M. P., R. Krishnan and F. Blaabjerg, 2002. *Control in Power Electronics*. Academic-Press, Inc.
20. Krishnan, R., 2001. *Electric Motor Drives: Modeling, Analysis and Control*. Prentice Hall, Inc.