

Analysis of Poultry Birds Production Performance using Artificial Neural Networks

¹A.S. Ajakaiye, ¹A.B. Adeyemo, ¹A.O. Osofisan and ²O.P.A. Olowu

¹Department of Computer Science, University of Ibadan, Nigeria

²Federal College of Agriculture, Akure, Nigeria

Abstract: Traditionally, cereal grains are the major source for the non-ruminant livestock feeds. Unfortunately in most developed countries there is always a shortfall between the production and demand for cereal grains. There is an intense competition between humans, livestock and industrial users for the little quantity of grains that are available. In the production of poultry birds feed composition is an important factor and the composition determines the consumption and conversion after other proper conditions have been met. In this study artificial neural network techniques is used to predict the weight of poultry birds (broilers) reared with different feed diets where maize has been supplemented with sorghum and an exogenous enzyme (α -glucanase). Various neural network models were tested. The best neural network model developed was a 4-input, 1-output Generalized Feed Forward Neural Network (GFFNN) having 1-hidden layer with 3 processing elements trained using the Back propagation of errors method. The results obtained confirmed that feed compositions comprising of mainly maize was still the best for poultry production, however the neural network was able to predict the optimal bird weights derivable from poultry diets where the maize content has been supplemented with sorghum dust.

Key words: Artificial neural networks, feed composition, poultry production

INTRODUCTION

Poultry Birds (Broiler) Production: The prediction of the production performance of poultry birds (Broilers) is dependent on many factors. These include factors such as temperature, biological factors, feed composition, feed conversion, diseases and feeding habits. All these factors vary in the way in which they affect poultry birds. The apparent non-linearity of the factors has made accurate prediction of the production performance difficult. Attempts to automate this process have been limited to feeds formulation using linear programming techniques. The non-linear nature of the problem has made it appealing to ANN modeling.

In the past, several breeds of chickens have been and are still being used for meat purposes. The present meat bird is a hybrid. The breed chosen depends on the objective and the market. Poultry meat, particularly from Broilers is superior to other type's of meat available for human consumption because of its tenderness, palatability, digestibility and low cholesterol level. Since commercial meat birds are bred to live for only 6-7 weeks, Broiler meat can efficiently and rapidly fulfill the shortage of meat requirement in human diet since it can be produced at the least possible time compared to other

meat producing animals. Broiler chicken is very sensitive to change. One breed of Broiler chicken, the Meat King will easily grow to 2.4-3.2 kg in ten weeks. On the average, broiler chickens will at the end of 7 weeks weigh 1.8 kg which is the commercial weight for these birds^[1]. Raising the chickens beyond 7 weeks has no significant commercial advantage.

In Nigeria, Sorghum, commonly called guinea corn, is the most widely cultivated cereal crop and the most important food crop in the savannah areas. There are many uses for Sorghum apart from its being used for food. It is used as supplement in bread, for native beer, it is also a major source of malt and malt extract next to barley in brewing industries. Whenever there is a shortfall in maize supplies some feed millers use locally produced sorghum as substitute for some proportion of maize in poultry feeds. In order to use by-products of other cereals (wheat offal, maize offal, sorghum dust, etc) to supplement maize in poultry feed production, some additives called enzymes are used to improve the overall performance of animals feed with such composition.

Enzymes are organic catalysts that speed up the rate of chemical reaction. Enzymes added to animal diet has been reported to aid digestion and absorption of poorly available nutrients or to reduce anti-nutritional factors

affecting the diet^[1]. There are several types of enzymes but those usually used are α -glucanase (Roxazyme-G) and Bakers Yeast (a crude enzyme that consists of other enzymes). Research has shown that improvement in meat-duck daily weight gain; feed conversion and reduction in litter moisture were obtained when enzymes were added to the diet. Improvement in live-weight gain reduced the growth of meat-ducks by 5 days^[2].

Artificial neural networks: Artificial Neural Networks (ANN) can be visualized as a mechanism for learning complex non-linear patterns in data. A key differentiator from other computer algorithms is that to a very limited extent, they model the human brain. This allows them to learn from experience; that is by training, rather than being programmed^[3]. ANN grew out of research in Artificial Intelligence. It specifically attempts to mimic the fault-tolerance and capacity to learn of biological neural systems by modeling the low-level structure of the brain. ANN is being successfully applied across an extraordinary range of problem domains. They are being used for problems of prediction, classification or even control. Linear modeling has been the commonly used technique in most modeling domains since linear models have well-known optimization strategies. Where the linear approximation was not valid (which was frequently the case) the models suffered accordingly. ANN are applicable in virtually every situation in which a relationship between the predictor variables (independents/inputs) and predicted variables (dependents/outputs) exists, even when that relationship is very complex and not easy to articulate in the usual terms of correlations or differences between groups. A simple network has a feedforward structure and such a structure has stable behavior. A recurrent network has connections back from later to earlier neurons but is prone to becoming unstable and has very complex dynamics. So far it is the feedforward structures that have proved most useful in solving real problems^[4].

An ANN consists of interconnected layers of neurons or processing elements. Data is passed through the network from layer to layer via synapses/connections, each of which is characterized by a weight/strength of its own. In addition an activation function is associated to limit the amplitude of the output of a neuron and is shown in Fig. 1.

To achieve the desired relationship between the input and output of a network, values must be derived for the connection weights and the activation functions. The process of this derivation is called supervised training.

ANNs offer advantages over traditional computational methods because of their parallel structures and the ability to generalize. Generalization refers to a neural networks ability to produce reasonable

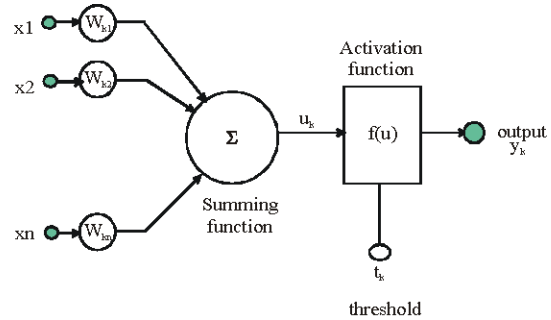

Fig. 1: A simple processing element

outputs from inputs not encountered during the training phase^[5]. If the network is properly trained, it has then learned to model the (unknown) function that relates the input variables to the output variables and can subsequently be used to make predictions where the output is not known. An important requirement for the use of a neural network is that it is known that (or at least strongly suspected that) there is a relationship between the proposed known inputs and unknown outputs. This relationship may be noisy but it must exist.

MATERIALS AND METHODS

An experimental investigation into the performance of poultry birds fed with maize supplemented with sorghum dust and Roxazyme-G (a commercial brand of an exogenous enzyme called α -glucanase) was carried out. Different mixtures of the feed were produced each having different concentrations of maize, sorghum dust and Roxazyme-G.

This research intends to optimize the experimental results obtained^[1] by training an artificial neural network on the experimental data in an effort to improve upon the results obtained experimentally. The trained neural network, if it can learn the problem will be able to predict other feed mixtures apart from those in the original experimental data set that will give optimal poultry performance when the birds are fed with such diet(s).

Data collection and pre-processing: The data used for the training of the artificial neural network models developed were those that contributed to the final weight of the poultry birds. These were the feed composition and the feed efficiency. Environmental factors were not considered. Seven experimental diets had been formulated (Table 1) and these were used to feed the chickens.

The Input variables selected are: percentage of maize, percentage of sorghum dust, percentage of Roxazyme-G enzyme in the feed composition and the computed feed efficiency. The output variable of interest is the final weight of the birds in grams (g). The data was collected

Table 1: Feed Composition for Broiler (Finisher)

Ingredient	Diet 1%	Diet 2%	Diet 3%	Diet 4%	Diet 5%	Diet 6%	Diet 7%
Maize	57.9	43.32	43.22	43.12	28.85	28.75	28.65
Sorghum Dust	0.0	14.48	14.48	14.48	28.95	28.95	28.95
Roxazyme-G	0.0	0.01	0.02	0.03	0.01	0.02	0.03
Brewery dry grain, soya, palm oil bone meal, oyster shell, methionine, premix, salt	42.1	42.19	42.28	42.37	42.19	42.28	42.37
Total (%)	100	100	100	100	100	100	100

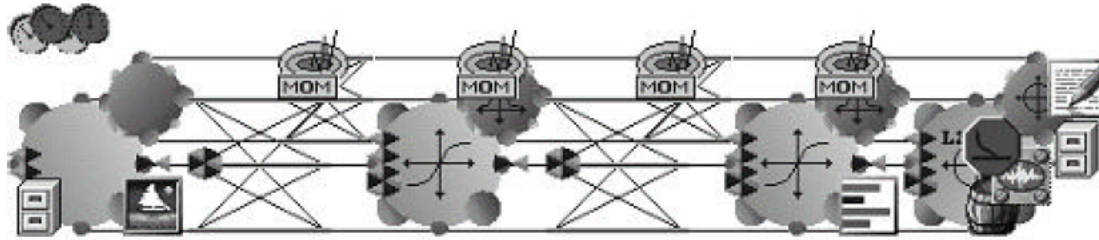

Fig. 2: A 3-layer neuro solutions MLP breadboard

over a period of 21 days and represents the second and final stage of the experiment. Data for this period was chosen because this is the stage at which the feeding of the chickens stabilizes and they do not have to undergo feed conversion. Also this is the stage which the birds are bought by small scale poultry farmers who then nurture them to maturity. The data which was divided into three data sets was transformed (where necessary), randomized and normalized before being used. Of the total amount of data samples used, 67% was used for the training set, 13% was used for cross validation while 20% was used as the testing data set.

Neural Network model development: The selection of an appropriate ANN topology is still more of an art than an exact science. Various neural models were considered since a single ANN problem can have different solutions which all lead to the same goal. A number of heuristics have however been developed to assist in the selection of an appropriate model and its components^[6].

The problem to be solved is actually a regression type problem and a number of ANN models can be used to solve this type of problem. In regression problems, the objective is to estimate the value of a continuous output variable, given the known input variables. Regression problems can be solved using the following network types: Multi-Layered Perceptron (MLP), Radial Basis Function/Generalized Regression (RBF/GRNN) Neural Networks, Generalized Feed Forward Neural Networks (GFFNN) and Linear Neural Network models.

NeuroSolutions, a GUI Windows based neural network simulation environment that also facilitates code generation was the ANN model development software used. Networks are constructed by placing and interconnecting components on a breadboard Fig. 2).

ANN model performance measures: The performance of ANN models can be evaluated using some standard parameters. These are:

Mean Squared Error (MSE): The mean squared error (MSE) and the Normalized Mean Squared Error (NMSE) can be used to determine how well the network output fits the desired output. It however does not necessarily reflect whether the two sets of data move in the same direction. For instance, by simply scaling the network output, the MSE can be changed without changing the directionality of the data. The correlation coefficient solves this problem.

The correlation coefficient (r): The value of r is usually confined to the range [1-, 1]. When r = 1 there is a perfect positive linear correlation. When r = -1, there is perfectly linear negative correlation. When r = 0 there is no correlation between the two quantities investigated. Intermediate values describe partial correlations.

Learning curve: The learning curve that shows how the mean square error evolves with the training iteration is a quantity that can be used to check the progress of learning. The difficulty of the task and how to control the learning parameters can be determined from the learning curve. When the learning curve is flat, the step size is increased to speed up learning. When the learning curve oscillates up and down the step size is decreased. In the extreme, the error curve increase steadily upwards, showing that learning is unstable. At this point, the network is reset. When the learning curve stabilizes after

RESULTS

Four network models that could be used for regression type problems were tested. These were the Linear Multi-Layer Perceptron (MLP) Neural Network, the Multi-Layer Perceptron (MLP) Neural Network, Generalized Feed Forward Neural Network (GFFNN) and Radial Basis Function/Generalized Regression (RBF/GRNN) Neural Network. Generalized Feed Forward networks are an extension of the MLP. In theory, a MLP can solve any problem that a Generalized Feed Forward network can solve. In practice, however, Generalized Feed Forward networks often solve the problem much more efficiently. RBF/GRNN is recommended for cases where the number of data samples is small and the data samples are scattered. The MLP and GFFNN models developed had the following configuration in common (Table 2):

The RBF/GRNN and Linear MLP network are different from the other two because they do not have hidden layer processing elements. The RBF/GRNN has 20 cluster

Table 2: Network configuration data

Network Configuration	
No. of input PE's	4
No of hidden layers	1
No of output PE's	1
Transfer function	TanhAxon
Learning rule	Momentum
Step size	1.000000
Momentum	0.700000
Minimum epochs	1000
Runs per epoch	3
No. of PE's used	Was varied between 1 and 4
Stopping criteria	Termination on MSE of Cross Validation set increase
Weight update	Online

Table 3: Comparison of best ANN models results

Performance metrics	GFFNN	MLP	RBF	Linear MLP
MSE	1747.646525	2686.010395	2899.24274	8942.84144
NMSE	0.503538728	0.773903783	0.835341118	2.576646329
Min Abs error	0.561144844	0.688054533	0.301841272	14.63172325
Max Abs error	99.20450759	96.09690793	97.95586558	165.66319
R	0.817874029	0.717280686	0.734772901	0.845901862
Trend accuracy	77.78%	77.78%	72.22%	55.55%

Table 4: Best network

Best networks	Training	Cross validation
No of PE's in hidden layer	3	3
Run #	3	3
Epoch #	345	1000
Minimum MSE	0.039266795	0.051792533
Final MSE	0.039282518	0.051792533

Table 5: Sensitivity analysis results

Sensitivity	F weight
Maize	3.93661789
SD	4.539208525
RG	2180.156783
Feedeff	6.387889966

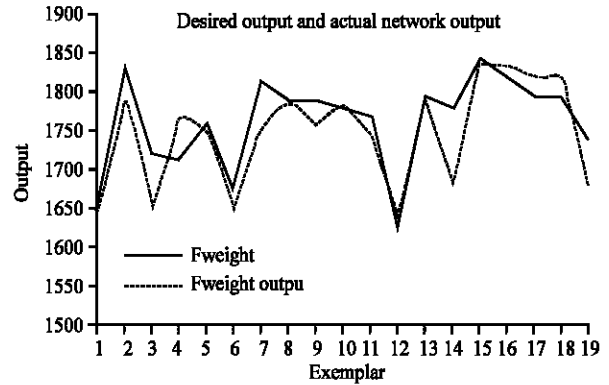

Fig. 3: GFFNN results

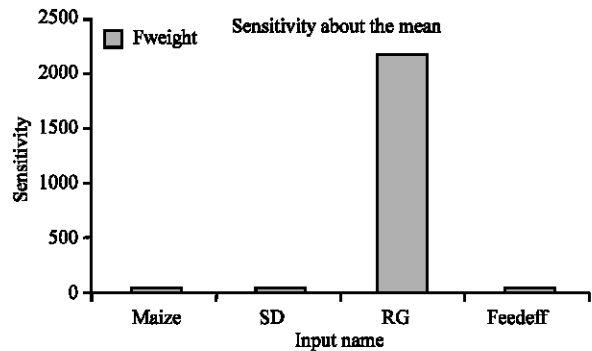

Fig. 4: Sensitivity analysis results

centers in its output layer and uses a Euclidean competitive learning rule. ANN models with 1, 2 3 and 4, Processing Elements (PE) in a single hidden layer were developed and trained on the training and cross validation data sets for each of the models (except the RBF/GRNN and Linear MLP models which had no hidden layers). The linear MLP network model that did not have any hidden layer performed poorly compared to the other network models tested. The results are shown in Table 3.

The GFFNN network model out-performed the MLP, RBF/GRNN and the Linear MLP neural networks. While the GFFNN recorded a NMSE of value of 0.503538728 and the MLP networks recorded a NMSE value of 0.773903783 on the test data sets, the RBF recorded a value of 0.835341118 while the Linear MLP recorded a value of 2.576646329. Table 4 shows the performance of the best GFFNN network model selected (with three PE's in its hidden layer) when trained on the training and cross validation data sets.

Figure 3 shows the result of the GFFNN networks performance on the test data set using the best network (with three PE's in its hidden layer). Charts obtained for the MLP and RBF/GRNN networks are similar to that shown in Fig. 3.

Table 6: Predicted network output

Maize	SD	RG	Feedeff	Final weight (g)
50	10	0.01	5	1852.886457
50	10	0.01	4	1840.572906
50	10	0.01	3	1822.51501
50	10	0.01	2	1799.281328
50	10	0.01	1	1771.664167
50	10	0.02	5	1836.9882
50	10	0.02	4	1844.456391
50	10	0.02	3	1840.768277
50	10	0.02	2	1827.046394
50	10	0.02	1	1806.239569
50	10	0.03	5	1825.972394
50	10	0.03	4	1812.688111
50	10	0.03	3	1813.697359
50	10	0.03	2	1824.923728
50	10	0.03	1	1824.772515
40	20	0.02	5	1764.863144
40	20	0.02	4	1738.593256
40	20	0.02	3	1722.803795
40	20	0.02	2	1728.98203
40	20	0.02	1	1743.942304
40	20	0.01	5	1753.219277
40	20	0.01	4	1764.898744
40	20	0.01	3	1775.143985
40	20	0.01	2	1764.223332
40	20	0.01	1	1739.478415
40	20	0.03	5	1799.821128
40	20	0.03	4	1772.387083
40	20	0.03	3	1742.740149
40	20	0.03	2	1714.634183
40	20	0.03	1	1695.039836
35	25	0.03	5	1786.642294
35	25	0.03	4	1757.401535
35	25	0.03	3	1726.383155
35	25	0.03	2	1696.103898
35	25	0.03	1	1669.341038
35	25	0.01	5	1712.251394
35	25	0.01	4	1693.321027
35	25	0.01	3	1693.62003
35	25	0.01	2	1709.079529
35	25	0.01	1	1709.879295
35	25	0.02	5	1748.423911
35	25	0.02	4	1717.774771
35	25	0.02	3	1689.739717
35	25	0.02	2	1669.248615
35	25	0.02	1	1663.770809
28	28	0.01	5	1693.247661
28	28	0.01	4	1667.082296
28	28	0.01	3	1648.108968
28	28	0.01	2	1641.245324
28	28	0.01	1	1649.775024
28	28	0.02	5	1732.428613
28	28	0.02	4	1701.582493
28	28	0.02	3	1673.201708
28	28	0.02	2	1649.319626
28	28	0.02	1	1631.74226
28	28	0.03	5	1772.167365
28	28	0.03	4	1741.693431
28	28	0.03	3	1710.530539
28	28	0.03	2	1681.047903
28	28	0.03	1	1655.200263
25	35	0.02	5	1717.511855
25	35	0.02	4	1687.426152
25	35	0.02	3	1660.529233
25	35	0.02	2	1638.07841
25	35	0.02	1	1620.487331
25	35	0.03	5	1757.871476
25	35	0.03	4	1726.765169

Table 6: Continuou

Maize	SD	RG	Feedeff	Final weight (g)
25	35	0.03	3	1696.096941
25	35	0.03	2	1668.068341
25	35	0.03	1	1644.178353
25	35	0.01	5	1679.081192
25	35	0.01	4	1653.517417
25	35	0.01	3	1632.813761
25	35	0.01	2	1617.571015
25	35	0.01	1	1608.633982

Table 5 and Fig. 4 show the result of the Sensitivity Analysis carried out on the test data results to determine the relative importance or contributions of the input variables to the network output.

The result indicates that the exogenous enzyme used (RG) contributed significantly to the determination of the networks output. All the other models tested gave similar results.

The GFFNN network was used to predict poultry performance. A production data set for the prediction program was generated. The output using the GFFNN is shown in Table 6.

The following can be inferred from the predicted network output:

- A predominant maize diet (maize 50%, sorghum dust 10%) will (depending on the concentration of exogenous enzyme used and the feed efficiency achieved) give a final bird weight of between 1852.89 grams and 1771.67 grams.
- An even mixture of maize and sorghum dust in the diet (maize 28%, sorghum dust 28%) will (depending on the concentration of exogenous enzyme used and the feed efficiency achieved) give a final bird weight of between 1741.69 grams and 1631.64 grams.
- A feed mixture of maize 25% and sorghum dust 35% will (depending on the concentration of exogenous enzyme used and the feed efficiency achieved) give a final bird weight of between 1757.7 grams and 1608.63 grams

CONCLUSION

ANN models for predicting poultry performance based on their feed composition has been developed. The GFFNN network model was selected as the one which gave the best performance on the test data used.

The artificial neural network model that was able to learn the problem was used to predict the final weight of poultry birds if they were fed with the different feed compositions suggested in the production data set. The ANN generated various results. The results indicate that supplementing the maize used in feed composition with as much as 35% of sorghum dust, the addition of exogenous

enzyme (α -glucanase) concentration of 0.01 and achieving a high feed efficiency value will produce poultry birds whose weight are close to the standard value of 1.8 kg (1800 g) in seven weeks.

The sensitivity analysis carried out on the input data showed the importance of the exogenous enzyme supplied in the determination of poultry feed composition performance. The relatively poor performance of the Linear ANN network shows that the data being modeled is linearly non-separable.

REFERENCES

1. Olowu, O.P.A., 2005. Effects of Exogenous Enzymes on the utilization on some fibrous feed resources by Broiler Chicken, Private Communications (Extracts from PhD thesis in the department of Animal production/Health, Federal University of Technology, Akure).
2. Nathan, J., 1985. Performance improvements following enzyme supplementation of wheat and barley based poultry birds. Private Communications.
3. Threapleton, L. and C.I. Wilson, 2003. Application of Artificial Intelligence for predicting Beer flavors from Chemical Analysis, Coors Brewers, Technical Centre, P.O Box 12, Cross Street, Burton-on-Trent, DE14 1XH, UK. Presented at the 29th European Brewing Congress on May 17-22, 2003 at Dublin, Ireland
4. Statsoft Electronic Statistics Textbook, 2002. Copyright, 1984-2003, Downloaded from www.statsoftinc.com/txtbook/glosd.html#Data Mining, June 2002.
5. Brewis, S., S. Rigg and J. Tindle, 1998. An AI method to Anticipate and Localize Faults within Telecommunication Networks, University of Sunderland and BT London, Proceedings Volume 2 World Multi-conference on Systems, Cybernetics and Informatics and Systems, Cybernetics and Informatics, SCT'98, 4th International Conference on Information Systems, Analysis and Synthesis, ISAS'98, Orlando, Florida USA. Organized by International Institute of Informatics and Systems, IIS. ISBN 980-07-5079-7, Copyright 1998 IIS
6. Ford, D.A. and M.C. Kelly, 2001. Using Neural Networks to Predict Lithology from Well Logs, SEG Int'l Exposition and Annual Meeting, San Antonio, Texas.