

The Effect of Media on Customer Satisfaction with Banking Services: Mediating Role of Corporate Image

¹Mansour Samadi and ²Roya Razmi

¹Faculty of Management, University of Shahid Chamran, Ahvaz, Iran

²Campus of Kish Island, University of Tehran, Kish Island, Iran

Abstract: Media refers to those responsible for the periodic creation of information and content and its dissemination over which there is editorial responsibility, irrespective of the means and technology used for delivery which are intended for reception by and which could have a clear impact on, a significant proportion of the general public. The purpose of this study is to examine the effectiveness of media in affecting corporate image and satisfaction in the banking industry. Measurement items are adapted from existing scales found in the marketing literature. Academic colleagues reviewed the items for face validity and readability. The scales are evaluated for reliability, convergent validity and discriminant validity using data collected in a survey of Iran Melli Bank's prospective customers in Iran. A structural equation modeling procedure is applied to the examination of the influences of media on corporate image and satisfaction. The research model was tested empirically using a sample of 186 respondents who had experience with banking services and referred to Iran's Melli bank branches during the period of research. The study found that media is one of the most effective factors influencing corporate image dimensions and satisfaction of banking services in the consumers' markets. There is a substantial research stream that examines media in the formation of corporate image, little is known about corporate image in the context of banking services. This study extends existing measurement of corporate image to a new setting.

Key words: Media, corporate image, satisfaction, e-Banking services, consumer behavior

INTRODUCTION

Many organizations spend time, resources and effort to build a strong image for their businesses. Millions are spent on advertising their products and services to create a strong, impressive brand and donations and charity events are sponsored in order to create an image of a socially responsible organization in the eyes of the public. To manage a corporation's images requires both an intimate understanding of how these images are formed and how to measure them. Modifying a corporation's images is dependent on knowing the current images and being able to change those factors on which they are based (Jalilvand and Samiei, 2012). As technology and mass media have continued to develop at exponential rates, the role of the media in business increases as well. Media has a large effect on the formation of corporate identity by reinforcing a company's image and reputation. This could include print media (newspapers, periodicals) and media disseminated over electronic communication networks such as broadcast media (radio, television and other linear audiovisual media services), online news services (such as online editions of newspapers and

newsletters) and non-linear audiovisual media services (such as television) (Feiz *et al.*, 2013). Global television networks and the rise of business news have caused the public representation of organizations to critically influence the construction and deconstruction of certain organizational identities more than ever before. Companies proactively choose to create media attention and use it as a tool for identity construction and strengthening and also to reinvent their images under the pressure of new technology. Media also has the power to produce and diffuse meanings a corporation holds, therefore giving stakeholders a negotiation of the organizational identity. Two principal strands to image management (Cooper *et al.*, 1989):

- Preservation and augmentation of an already benign image
- The other is damage limitation and repair

Corporate image management becomes an on-going, synergistic management tool, rather than a one-time corporate image exercise. Today's bank managers can develop an integrated approach to managing all verbal,

visual and environmental elements and media used in communicating the organization's identity to each of the banks' constituents (Dutton *et al.*, 1994). As technology and mass media have continued to develop at exponential rates, the role of the media in banks increases as well. The media has a large effect on the formation of corporate identity by reinforcing a company's image and reputation. Global television networks and the rise of business news have caused the public representation of organizations to critically influence the construction and deconstruction of certain organizational identities more than ever before. Many organizations such as banks pro-actively choose to create media attention and use it as a tool for identity construction and strengthening and also to reinvent their images under the pressure of new technology. The media also has the power to produce and diffuse meanings a corporation holds, therefore giving stakeholders a negotiation of the organizational identity. Despite the significant impact of media in the forming bank image, little research has been done to investigate media in this field. Based on the ration in the literature, we discuss that media can affect the corporate image and customers' satisfaction. Since no relevant explanation has been proposed to explain these effects this study applied experimental design methodology to explore; the impact of media on bank image and the impact of bank image on customer satisfaction. The rest of this study is organized as below. First, we provide a review on the literature related to media and corporate image. Second, we introduce hypotheses and the research model. Next, we describe the research methodology and discuss the statistical results. Finally, we summarize the findings and discuss the implications for both research and practice.

Theoretical background

Concept of corporate image: Corporate image is an intuitively appealing concept. Research in the area of corporate image is vital as it is a valuable asset that companies need to manage (Abratt and Mofokeng, 2001). A favorable corporate image can boost sales through increased customer satisfaction and loyalty (Andreassen and Lindestad, 1998) in addition to attracting both investors (Fombrun, 1997) and future employees (Lemmink *et al.*, 2003). It can weaken the negative influence of competitors, enabling organizations achieve higher levels of profit. Corporate image (sometimes also referred to as organizational image or institutional image) can be defined as the "image associated with the name of an organization" (Rynes, 1991). It has been suggested two opposing points of view when conceptualizing corporate image. The first is related to the organizational literature, while the second is closer to the marketing literature

(Gioia *et al.*, 2000). From the organizational perspective, corporate image is conceptualized as the way in which an organization's members believe external stakeholders perceive their organization (Dutton *et al.*, 1994) or the way that an organization's managers would like outsiders to view their company. Following this approach, corporate image is based on perceptions of stakeholders of the organization (Hatch *et al.*, 2003). Consequently, rather than focusing on the perceptions of the company's members, the views of customers, shareholders, the media, the general public and any other external stakeholders are the basis of image (Hatch *et al.*, 2003). This second approach is adopted within this study. Nevertheless, it is usual in the marketing literature to focus on customers and it is accepted that corporate image represents the beliefs, attitudes, impressions and associations held by customers about a corporation (Keller, 1993). The associations that constitute corporate image relate to both tangible and intangible characteristics. For example, Padgett and Allen (1997) note that the image of service companies includes attributes, functional consequences and symbolic meanings.

Determinants of corporate image: Corporate image is the picture that company's audiences have of it. It will be determined by all a company's actions. The problem a company faces is that different audiences will interpret a message in different ways. The management of the corporate image is thus an ongoing task. Corporate image includes information and inferences about the company as an employer as a seller as an investment and as a corporate citizen (Adjei *et al.*, 2010). A company will have more than one image depending on the nature of the interaction it has with the different groups. Since people tend to humanize companies, corporate image may also include characteristics often attributed to humans such as "caring", "friendly" and "ruthless" and so on. The first step in attempting to influence and manage the corporate image of an organization is to understand the process by which corporate image formed. There are numerous sources that influence and hence affect the image of an organization (Wu *et al.*, 2011). These sources can be broadly classified into two major groups or spheres of influence) internal and controllable sphere of influence and) external and non-controllable sphere of influence.

Internal spheres of influence: Within the internal sphere of influence are at least five major sources that help form a corporate image:

Corporate personality and identity: Every company has a personality which can be defined as the sum total of the

characteristics of that organization. These characteristics can be quantitative (e.g. size of organization, volume of sales) or qualitative (e.g. reputation, quality of products and services) in nature and they serve to distinguish one organization from another. The qualitative and quantitative characteristics collectively comprise the corporate personality. The term, corporate personality, refers to who and what the company is rather than how the company is perceived by the public. A company also has an identity which can be described as an ideal self-image. Ideal self-image is that image which the company would like the public to hold.

Corporate advertising: Corporate advertising seeks to inform and influence the public's attitudes about a company's actions, characteristics or viewpoints is a tool often used to deliver this information and by doing so influence stakeholders' image of the corporation.

Brand image: Brand image consists of functional, symbolic and experiential aspects of the product or service including the influence of product advertising on the brand. Intuitively one would expect a significant interaction between brand image and corporate image. This is especially true for brand names such Sony where the company name is also the brand name. In such cases, the interaction effect would be maximum.

Public relations: Public relation programs can be used to project an image of a company that is environmentally conscious which can do wonders for the company.

Frontline employee behavior: In many situations, direct contact with frontline employees of the company serves to form impressions about the company. The courtesy and knowledge of the telephone receptionist, the efficiency of the service engineer or the sincere concern of a sales manager in dealing with the complaints of a customer will help form or reinforce an organizations' image.

External sphere of influence

Country of origin image: Research has shown that knowledge of the country of origin affects both the image of the brand and the company. This interaction helps explain the halo effect associated with Japanese cars and German machinery. Consumers, for example, may form an image that Mitsubishi is a maker of high quality automobiles just knowing Mitsubishi is a Japanese company without ever having had direct dealing with the company (Lemmink *et al.*, 2003).

Press reports: There is also a link between company public relations, press reports and the image of the company.

Word of Mouth (WOM): WOM is personal communications between two or more people. This includes stakeholder's conversations with family, friends, colleagues, acquaintances and so on. In the absence of direct interaction with the organization, the stakeholder may form opinions and impressions of the organization based on what others say about the company (Rynes, 1991).

Measuring corporate image in the banking context: Nguyen and Leblanc (2001) stated that corporate image is not a single entity, since it depends on the perception of each specific group of people and on the type of experiences and contacts they have had with the company. When tackling the analysis of aspects that involve a certain degree of abstraction as is the case of image projected by a company in the mind of its consumers or the perceived quality of its products, we should begin by implying the certain complexity of such a study when dealing with firms devoted to the marketing of services. Indeed, services are a special case because of their intangibility, the difficulty in separating production from consumption their heterogeneous nature and the fact that they are perishables. This is due to the need to include aspects that are typical of the supply of a service as against the distribution of tangible goods (Jun and Cai, 2001). These additional aspects give rise to the development of service quality measurements that include dimensions that are different to those used when analyzing perceived quality in the marketing of tangible goods such as SERVQUAL (Zeithaml *et al.*, 1990) scale. The concept of service quality has often been associated with the idea of business image. Service quality comes from a comparison between actual results and the initial expectations of the customer, bringing the concept closer to the idea of satisfaction (Cooper *et al.*, 1989). Thus, the concept of image is more abstract than the idea of service quality. A clear relationship has been observed in the literature between image and perceived quality. For example, Gronroos (1988) defines service quality based on two dimensions (the technical or results dimension and the functional dimension, related to the process) and associates them with the corporate image, since this image can determine what is expected from the service provided by the company. This is how the connection between the concepts of service quality and image may be observed. In the banking industry, there are many researches focusing on analyzing the perceived quality of the service being offered. For instance, Bahia and Nantel (2000) developed a reliable and valid scale composed of 31 items grouped into six dimensions which enabled them to measure perceived quality of banking services. We want

to repeat that quality research have made a major contribution to a better understanding of the image concept, due to the great influence exerted by certain aspects such as service quality on the forming of the image as perceived by consumers.

Hypothesis development: The above presented arguments lead to our research hypotheses:

- H₁: media has a significant impact on perceptions of access to services
- H₂: media has a significant impact on familiarity with offered services
- H₃: media has a significant impact on perceptions of personal contacts
- H₄: media has a significant impact on perceptions of security
- H₅: media has a significant impact on reputation of bank
- H₆: perceptions of access to services has a significant impact on customer satisfaction
- H₇: familiarity with offered services has a significant impact on customer satisfaction
- H₈: perceptions of personal contacts has a significant impact on customer satisfaction
- H₉: perceptions of security has a significant impact on customer satisfaction
- H₁₀: reputation of bank has a significant impact on customer satisfaction

In this study, we will develop the research model that provides a basis for the assumed effects and test these effects in a new empirical study. The assumed link between media and corporate image has not been examined empirically before and will be analyzed in the empirical study presented subsequently (Fig. 1).

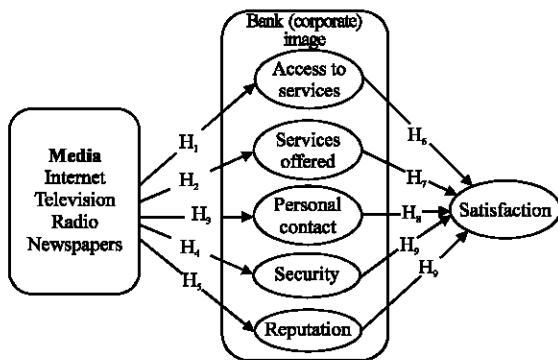

Fig. 1: Research model

MATERIALS AND METHODS

Measurement: To achieve the study objectives, a self administered survey questionnaire was developed based on the findings of the literature review. The questionnaire was pre-tested and revised. The survey consisted of four parts covering the following issues: media; bank image; satisfaction and demographics. In the media section with four items, respondents were asked about using various media. In the bank image section, with fifteen items, respondents were asked to rate their level of agreement on the perceptions of bank image (Flavian *et al.*, 2004). In the satisfaction section with three items, respondents were asked about their satisfaction with (Minkiewicz *et al.*, 2011). Measurement of media, bank image and satisfaction were carried out by a 5-point Likert scale, ranging from strongly agree (1) to strongly disagree (5). The advantage of using an interval scale is that it permits the researchers to use a variety of statistical techniques which can be applied to nominal and ordinal scale data in addition to the arithmetic mean, standard deviation, product-moment correlations and other statistics commonly used in marketing research (Malhotra, 1999). The measures are presented in Table 1. The last section of the questionnaire gathered respondents’ demographic information such as age, gender, education and monthly income as give in Table 1.

Media (Abzari *et al.*, 2014): Using media for gathering information about banking services:

- (M1) Internet
- (M2) Television
- (M3) Radio
- (M4) Newspapers

Table 1: Demographical characteristics of respondents

Characteristics	Frequency	Percentage	CF (%)
Age			
25 or Under	34	18.28	18.28
26-35	42	22.58	40.86
36-45	58	31.18	72.04
46-55	35	18.82	90.86
Above 55	17	9.14	100.00
Gender			
Male	129	69.35	69.35
Female	57	30.65	100.00
Monthly income			
Under \$200	23	12.37	12.37
\$200-\$299	51	27.42	39.79
\$300-\$600	65	34.95	74.73
Above \$600	47	25.27	100.00
Education			
High school or below	30	16.13	16.13
2 year college or associate’s degree	34	18.28	34.41
Bachelor’s degree	67	36.02	70.43
Postgraduate	55	29.57	100.00

Corporate image dimensions (Flavian *et al.*, 2004)

Access to services:

- (AS1) Convenience in the service
- (AS2) Easy to use
- (AS3) Necessary time to carry out the transactions

Services offered:

- (SO1) Attractiveness of the products and services offered
- (SO2) Quantity of products and services available
- (SO3) Commission paid for services

Personal contact:

- (PC1) Human contact
- (PC2) Friendliness and treatment received
- (PC3) Financial advice

Security:

- (S1) Security in transactions
- (S2) Security of deposits
- (S3) Security of data

Reputation:

- (R1) I believe that this bank does what it promises for its clients
- (R2) This bank or savings bank has a good reputation
- (R3) I believe that the reputation of this bank or savings bank is better than that of the rest of the banks

Customer satisfaction (Minkiewicz *et al.*, 2011):

- (CS1) I am satisfied with my decision to refer the bank
- (CS2) I feel good about my decision to refer the bank
- (CS3) My choice to refer the bank was a wise one

Data collection and analyses: The questionnaires were distributed based on a convenience sampling method and collected at Iran's Melli bank (a well-known bank in Islamic World) branches in Tehran during the month of November 2015. Three hundred questionnaires were distributed and 186 usable samples were obtained after excluding the incomplete ones, yielding a 62% response rate from those who agree to participate. Cronbach's alpha was used to verify the internal consistency reliability. Data analysis involves descriptive statistics using SPSS and structural equation modeling using AMOS structural equation program. AMOS is designed to estimate and test Structural Equation Models (SEMs). SEMs are statistical models of linear relationships among latent (unobserved) variables and manifest (observed)

variables. Its purpose is estimating the coefficients in a set of structural equations. For this research AMOS is used to investigate the causal relationships where the path coefficients are tested for significance and goodness-of-fit. The overall model fit measures were used to evaluate the fit of the structural model. In estimating the Goodness-of-Fit Indices (GFI) for measurement and structural models, χ^2 -test was used. In addition, the Root Mean Square Error of Approximation (RMSEA) was used as an absolute fit index. The Incremental Fit Index (IFI), the Tucker-Lewis index (TLI) and the Comparative Fit Index (CFI) were used as incremental fit indices. Standardized estimates were used in reporting the causal relationships between the exogenous and endogenous constructs. The path diagram of the structural model specified (Fig. 1) is proposed based on the past literature in theoretical background.

RESULTS AND DISCUSSION

Sample profile: Of a total sample 186 respondents, 69.35% (129) were male and 60.65% (57) were female. A large majority of respondents' age were between ranges of 26-35 = (22.58%) and 36-45 = (31.18%). The majority of the respondents had 300-600 dollars (34.95%) and 200-299 dollars (27.42%) monthly income. In addition, majority of the respondents' education were bachelor's degree (36.02%) and postgraduate (29.57%). Descriptive statistics are displayed in Table 1.

Measurement model: The proposed structural model was estimated by Structural Equation modeling (SEM) which included a test of the overall model fit and individual tests of the significance of the relationships among the variables. These tests indicated the relationship between media, bank (corporate) image and customer satisfaction. The estimations of the parameters and the overall fit index of the measurement model are based on the Maximum Likelihood (ML) Method. The basic conditions assumed for the use of ML estimation are met or closely approximated in the study. Further, the sample is sufficiently large ($n = 186$ cases), the scale of observed variables is continuous and no violations of multivariate normality are found in the survey responses. As presented in Table 2, the reliability of the measurement items was verified using Cronbach's α to assess the internal consistency of the constructs in the applied model. The level of internal consistency for each construct was acceptable with the alpha ranging from 0.727-0.788 which exceeded the minimum hurdle of 0.60 (Hair *et al.*, 1998). All measurement items had standardized loading estimates of 0.5 or higher (ranging

Table 2: Psychometric characteristics of measures

Construct	Item	Standardized loading	t-statistic	Mean	St. deviation	Cronbach's α
Media CR = 0.815, AVE = 0.622	M1	0.653	9.040	4.35	1.135	0.788
	M2	0.567	8.184	4.32	1.194	
	M3	0.604	-	3.86	1.298	
Bank (corporate) image CR = 0.832, AVE = 0.574	AS1	0.549	7.302	3.81	1.011	0.760
	AS1	0.755	8.459	3.89	1.560	
	AS1	0.583	9.006	3.55	1.945	
	SO1	0.499	6.740	3.53	1.114	
	SO1	0.530	8.224	3.83	1.482	
	SO1	0.527	7.476	3.66	1.294	
	PC1	0.696	8.353	3.92	1.743	
	PC1	0.778	8.210	3.95	1.521	
	PC1	0.666	6.752	3.83	1.438	
	S1	0.702	9.483	3.72	1.202	
	S1	0.591	8.464	3.33	1.175	
	S1	0.590	8.454	3.65	1.081	
Customer satisfaction CR = 0.883, AVE = 0.684	R3	0.627	8.820	3.41	1.302	0.727
	R3	0.614	8.693	3.39	1.177	
	R3	0.573	-	3.38	1.189	
	PI1	0.518	-	4.16	0.801	
	PI2	0.627	7.551	4.22	0.852	
	PI3	0.520	6.790	4.11	0.828	

CR: Construct Reliability, AVE: Average Variance Extracted

Table 3: Correlation matrix

Matrix	Media	Access to services	Services offered	Personal contact	Security	Reputation	Satisfaction
Media	1.000						
Access to services	0.356	1.000					
Services offered	0.408	0.371	1.000				
Personal contact	0.396	0.395	0.381	1.000			
Security	0.424	0.321	0.415	0.398	1.000		
Reputation	0.387	0.352	0.347	0.408	0.402	1.000	
satisfaction	0.470	0.403	0.299	0.420	0.277	0.266	1.00

All of the correlations are significant at the 0.01 level

from 0.499-0.778) at the alpha level of 0.05, indicating the convergent validity of the measurement model. Construct reliability was verified to estimate convergent validity; each construct had acceptable construct reliability with the estimates ranging from 0.815-0.883 (Hair *et al.*, 1998).

In addition, because the Average Variance Extracted (AVE) from all three constructs exceeded the minimum criterion of 0.5 (ranging from 0.574-0.684), convergent validity was assured (Hair *et al.*, 1998). To test the discriminant validity among the constructs, we estimated correlations among the constructs to determine whether they were significantly different from 1; the confidence intervals of the correlations, calculated as correlations $\pm 1.96 \times$ standard error of estimate, did not contain 1 so these results indicated the discriminant validity of the measurement model. The correlations for the constructs are shown in Table 3. Overall these measurement results are satisfactory and suggest that it is appropriate to proceed with the evaluation of the structural model.

Structural model: Figure 2 shows the overall explanatory power, the standardized path regression coefficients that

Table 4: Maximum likelihood estimates for research model (n = 186)

Model fit statistics	
Structural model	Cut-off value
Chi-square = 83.2	-
df = 51	-
p-value <0.05	-
Nommed chi-square = 1.631	1.0-3.0
GFI = 0.951	>0.90
NFI = 0.936	>0.90
CFI = 0.958	>0.90
TLI = 0.952	>0.90
RMR = 0.48	<0.50
RMSEA = 0.034	<0.08: good fit

indicate the direct influences of the predictor upon the predicted latent constructs for the model and associated t-values of the paths of the research model. The model fit indices of the structural model and the cut-off value of those fit indices are presented in Table 4. The goodness of fit statistics show that the structural model fit the data reasonably well. The 7-item model produced a chi-square of 83.2 (df = 51, p = 0.003). While the overall chi-square for this measurement model was significant (p<0.05) it is well established that this statistic is sensitive to large sample sizes (Hair *et al.*, 1998). To alleviate the sensitivity of the Chi-square statistics, the value of Chi-square is commonly

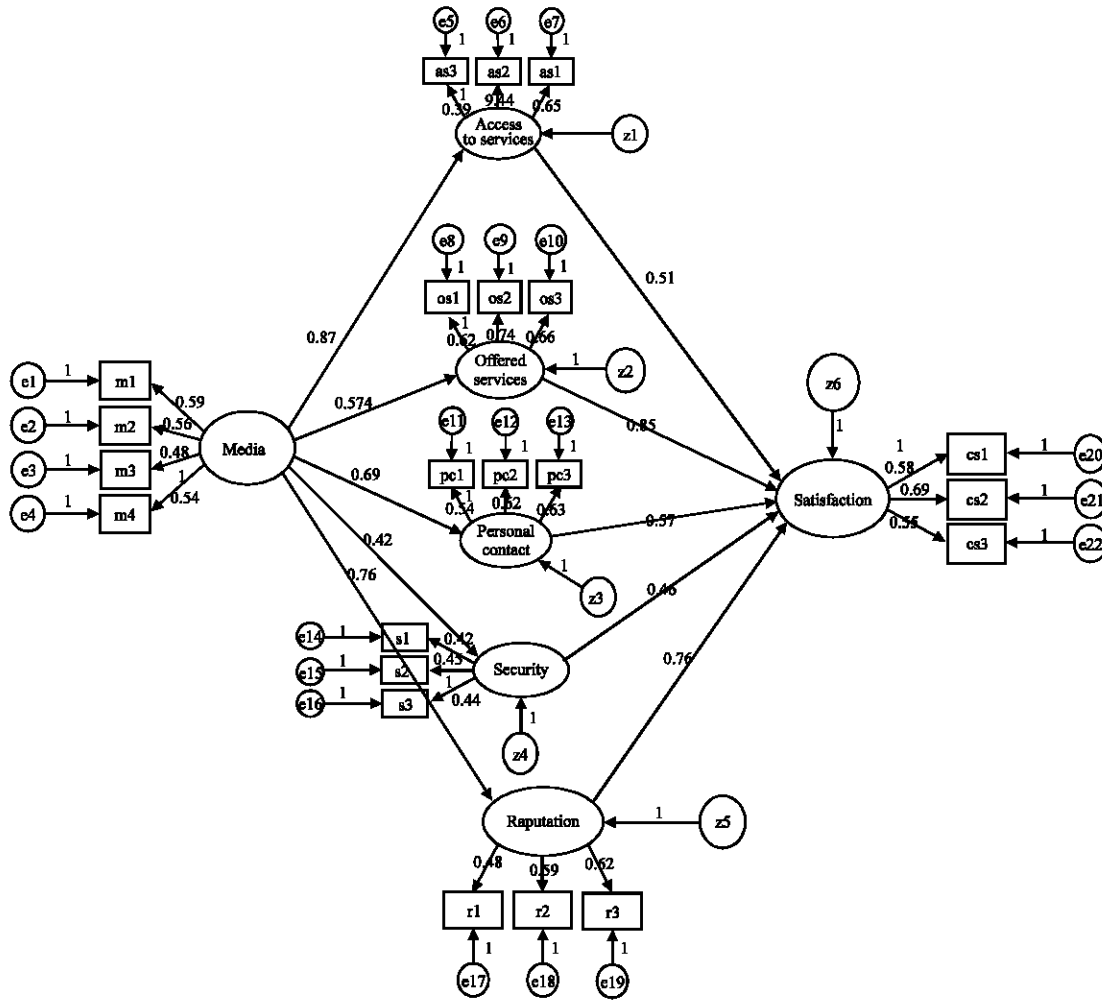

Fig. 2: Standardized regression coefficients-proposed model

Table 5: SEM results

Independent variables	Dependant variable	Estimate	Standardized estimate	Standard error	t-statistic	p-values
Media	Access to services	0.997	0.866	0.127	7.842	**
Media	Services offered	0.312	0.574	0.140	3.224	**
Media	Personal contact	0.325	0.690	0.129	3.518	**
Media	Security	0.458	0.421	0.185	3.157	**
Media	Reputation	0.789	0.757	0.110	7.457	**
Access to services	Satisfaction	0.529	0.511	0.143	6.958	**
Services offered	Satisfaction	0.877	0.846	0.134	7.259	**
Personal contact	Satisfaction	0.583	0.566	0.106	4.238	**
Security	Satisfaction	0.449	0.457	0.141	3.859	**
Reputation	Satisfaction	0.777	0.754	0.148	4.958	**

**Significant at the $p < 0.05$ level (two-tailed)

divided by the degrees of freedom. The re-estimated Chi-square value was 1.631 and this new value is within an acceptable cut-off value range, from 1.0-3.0. The goodness fit index (GFI = 0.951 with 1 indicating maximum fit), Comparative Fit Index (CFI = 0.958, 1 = maximum fit), the comparative fit index (NFI = 0.936 with 1 indicating maximum fit), Tucker-Lewis index (TLI = 0.952, 1 =

maximum fit) and the incremental fit index (IFI = 0.949) met the proposed criterion of 0.90 or higher. Finally, the root mean square error of approximation (RMSEA = 0.034 with values < 0.08 indicating good fit), one of the indices best suited to our model with a large sample, indicated that the structural model was a reasonable fit. Table 5 presents the results of the individual tests of the significance of the

relationship among the variables. Among the 10 relationships tested, all relationships were found to be significant at the alpha level of 0.05. Media had a significantly positive impact on perceptions of access to services ($\beta = 0.886$, $t = 7.842$), familiarity with offered services ($\beta = 0.574$, $t = 3.224$), perceptions of personal contacts ($\beta = 0.690$, $t = 3.518$), perceptions of security ($\beta = 0.421$, $t = 3.157$) and reputation of bank ($\beta = 0.757$, $t = 7.457$), supporting H_1 , H_2 , H_3 , H_4 and H_5 . These results suggest that media plays a major role as an important antecedent of bank (corporate) image. Furthermore, perceptions of access to services ($\beta = 0.511$, $t = 6.958$), familiarity with offered services ($\beta = 0.846$, $t = 7.259$), perceptions of personal contacts ($\beta = 0.566$, $t = 4.238$), perceptions of security ($\beta = 0.457$, $t = 3.859$) and reputation of bank ($\beta = 0.754$, $t = 4.958$) had positively influenced customer satisfaction with banking service, supporting H_6 , H_7 , H_8 , H_9 and H_{10} (Fig. 2).

CONCLUSION

We developed a conceptual model that illustrates the influence of media on corporate image formation and consequently, customer satisfaction. The model includes seven dimensions including determinant and consequence of corporate image with a case of banking industry. We assessed bank (corporate) image with five dimensions containing access to services, services offered, reputation, security and personal contact proposed by Flavian. As demonstrated in this research, media has a positive and significant influence on the five key dimensions of bank image. Further, the dimensions of access to services, services offered, reputation, security and personal contact were found to have positive and significant influence on customer satisfaction with banking services. To our knowledge this is the first study that investigates the relationships among media, corporate image dimensions and customer satisfaction in the context of banking industry. Our findings have several implications for bank managers. Firstly, marketing managers should employ various media, particularly social media and television to establish a unique image of the bank in the mind of customers. When customers have a positive image they would share their positive feelings and information about the bank to other customers by word of mouth communications. Word of mouth has been known as the major information source of customers in the context of high-risky purchases. Secondly, managers should compare the effectiveness of various media in the process of corporate image formation. Hence, serious market research is needed to survey customers and to understand what type of media has the most effectiveness

for banks. Then, it should be invested as the main media that create a mass positive image of bank among a wide range of customers. Thirdly, managers can focus on the main dimensions of bank image suggested in this research. For instance they can improve the security of banking service, provide more accessible services and reinforce the front line employee's contacts with customers. This would be possible by implementing service quality requirements and strategies (Zeithaml *et al.*, 1996).

REFERENCES

- Abratt, R. and T.N. Mofokeng, 2001. Development and management of corporate image in South Africa. *Eur. J. Market.*, 35: 368-386.
- Abzari, M., R. Abachian and L. Nasrolahi Vosta, 2014. Analysing the effect of social media on brand attitude and purchase intention: The case of Iran Khodro company. *Procedia Soc. Behav. Sci.*, 143: 822-826.
- Adjei, M.T., S.M. Noble and C.H. Noble, 2010. The influence of C2C communications in online brand communities on customer purchase behavior. *J. Acad. Marketing Sci.*, 38: 634-653.
- Andreassen, T. and B. Lindestad, 1998. Customer loyalty and complex services. *Int. J. Service Ind. Manage.*, 9: 7-23.
- Bahia, K. and J. Nantel, 2000. A reliable and valid measurement scale for the perceived service quality of banks. *Int. J. Bank Marketing*, 18: 84-91.
- Cooper, A.R., M.B. Cooper and D.F. Duhan, 1989. Measurement instrument development using two competing concepts of customer satisfaction. *J. Consum. Satisfaction Dissatisfaction Complaining Behav.*, 2: 28-35.
- Dutton, J.M., J.M. Dukerich and C.V. Harquail, 1994. Organization May 14, 2016al images and member identification. *Admin. Sci. Q.*, 39: 239-263.
- Feiz, D., M. Fakharyan, M.R. Jalilvand and M. Hashemi, 2013. Examining the effect of TV advertising appeals on brand attitudes and advertising efforts in Iran. *J. Islamic Market.*, 4: 101-125.
- Flavian, C., E. Torres and M. Guinaliu, 2004. Corporate image measurement: A further problem for the tangibilization of Internet banking services. *Int. J. Bank Market.*, 22: 366-384.
- Fombrun, C., 1997. *Reputation Realizing Value from Corporate Image*. Harvard Business School Press, Boston, Massachusetts, Pages: 441.
- Gioia, D.A., M. Shultz and K.G. Corley, 2000. Organizational identity, image and adaptive instability. *Acad. Manage. Rev.*, 25: 63-81.

- Gronroos, C., 1988. *A Service Quality: The Six Criteria of Good Service Quality*. St. John's University Press, New York, USA.
- Hair, Jr. J.F., R.L. Tatham, R.E. Anderson and W.C. Black, 1998. *Multivariate Data Analysis*. 5th Edn., Prentice Hall International, Englewood Cliffs, NJ., USA., ISBN-13: 978-0138948580, pp: 169-215.
- Hatch, M.J., M. Schultz and J. Williamson, 2003. Bringing the corporation into corporate branding. *Eur. J. Market.*, 37: 1041-1064.
- Jalilvand, M.R. and N. Samiei, 2012. The effect of electronic word of mouth on brand image and purchase intention. *Market. Intelligence Plan.*, 30: 460-476.
- Jun, M. and S. Cai, 2001. The key determinants of internet banking service quality: A content analysis. *Int. J. Bank Market.*, 19: 276-291.
- Keller, K.L., 1993. Conceptualizing, measuring and managing customer-based brand equity. *J. Market.*, 57: 1-22.
- Lemmink, J., A. Schuijf and S. Streukens, 2003. The role of corporate image and company employment image in explaining application intentions. *J. Econ. Psychol.*, 24: 1-15.
- Malhotra, N.K., 1999. *Marketing Research: An applied orientation*. Prentice Hall, Upper Saddle River, New Jersey.
- Minkiewicz, J., J. Evans, K. Bridson and F. Mavondo, 2011. Corporate image in the leisure services sector. *J. Serv. Market.*, 25: 190-201.
- Nguyen, N. and G. Leblanc, 2001. Corporate image and corporate reputation in customers' retention decisions in services. *J. Retail. Consum. Ser.*, 8: 227-236.
- Padgett, D. and D. Allen, 1997. Communicating experiences: A narrative approach to creating service brand image. *J. Advertising*, 26: 49-62.
- Rynes, S.L., 1991. Recruitment Job Choice and Post Hire Consequences: A Call for New Research Directions. In: *Handbook of Industrial and Organizational Psychology*. Dunnette, M.D. and L.M. Hough (Eds.). Consulting Psychologists Press, Palo Alto, California, pp: 399-444.
- Wu, P.C.S., G.Y.Y. Yeh and C.R. Hsiao, 2011. The effect of store image and service quality on brand image and purchase intention for private label brands. *Australasian Market. J.*, 19: 30-39.
- Zeithaml, V.A., A. Parasuraman and L.L. Berry, 1990. *Delivering Quality Services*. The Free Press, New York, USA.
- Zeithaml, V.A., L.L. Berry and A. Parasuraman, 1996. The behavioral consequences of service quality. *J. Market.*, 60: 31-46.