

Energy Losses Minimization in Induction Motor by the Frequential Regulation of the Speed

¹K. Haouari, ²A. Haddouche, ¹A. Chine and ¹S.E. Bouazza

¹Department of Electrotechnics,

²Department of Electromechanical Engineering,

Faculty of Science Engineering, Badji Mokhtar University Annaba, Algeria

Abstract: In this research work, we demonstrate by the analytical method then by verifying the results obtained by experimental essays that during the frequencial regulation of speed of an induction motor, the energy losses are minimized and are inversely proportional to the linear ramp acceleration time and so there is a considerable energy saving.

Key words: Energy saving, induction motor, frequencial regulation, frequency converter, direct starting, linear ramp starting

INTRODUCTION

Electric motors consume more than half of the energy produced by power stations, almost threequarters of the electrical consumption and almost the half of the commercial electrical consumption in industrial countries. Motors are by far the most important type of electric charges and so constitute the main targets to achieve energy saving. Owing to their simple and robust construction, the asynchronous motors and especially those squirrelcage types, represent about 90-95% of the electrical energy consumption of electric motors, witch is equivalent to about 53% of total electrical energy consumption. They are widely used as electrical drives in industrial and domestic applications (Rini, 2005).

Owing to the importance of induction motors, this work aims at studying and at analyzing the energy balance of the induction motors (Guy and Eddie, 2000).

Also when a frequency converter is used in the induction motor power circuit, ca energy be saved during frequency regulation of the speed (Guy and Eddie, 2000; Grellet, 1989; Wided de Ghaichia, 2001).

MINIMIZATION OF THE ENERGY LOSSES ANALYZES ENERGETICS

According to the theory of the electric machines (Guy and Eddie, 2000; Grellet, 1989) the equation of the energy balance of an induction motor can be represented under the following form:

$$P_1 = P_2 + P_{e1}^{\uparrow} + P_{e2}^{\uparrow} + P_f^{\downarrow} + P_{mec} + P_{sup} \quad (1)$$

Where:

- P_1 : Absorbed power expressed in Wattts
- P_2 : Useful power
- P_{e1} and P_{e2} : Losses by joule effect in the stator and rotor windings
- P_f : Losses in the iron
- P_{mec} : Mechanical losses due to the frictions in bearings
- P_{sup} : Supplementary losses in the steel.

Arrows indicate the increase or the decrease of every component. Moreover, these variations are almost equal.

LOSSES OF THE DIRECT STARTING UP

The direct starting of the motor is used network in the direct connection to the power grid. According to the general theory of the electric machines, the sum of the losses, is composed of two parts:

$$P = P_c + P_v \quad (2)$$

$$P_c = P_f + P_{mec} + P_{sup} \quad (3)$$

Constant losses do not depend on speed. This assumption is not exact because in reality these losses depend on speed but not considerably. This is because of the fact one of the components increases the other will decrease.

$$P_v = P_{e1} + P_{e2} \quad (4)$$

Variable losses caused by the load which is related to speed by electromechanical characteristics. Considering the losses during the transient process in direct starting conditions:

U = Constant; supply tension
f = Constant; grid frequency

Having the instantaneous losses Pc and Pv (t) which are time dependent, we will have the energy losses as follows (Guy, 2000; Grellet, 1989):

$$\begin{aligned} \Delta W_{pt} &= \int_0^{t_{pt}} P(t)dt \int_0^{t_{pt}} [P_c + P_v(t)]dt \\ &= \Delta W_{ptc} + \Delta W_{ptv} \end{aligned} \quad (5)$$

Where:

- w_{ptc} : Constant energy losses during the transient process (t_{ptc}), which is linearly time dependent since $P_c = \text{Const}$.
- w_{ptv} : Variable energy losses during the transient process which depends on the behavior of time dependent power.

Let us consider the expression (5) in more detail. The rotor energy losses during the transient process could be expressed as in (5) by:

$$\Delta W_{pt} = \int_0^{t_{pt}} c \cdot \omega_0 \cdot g \cdot dt \quad (6)$$

- c : Motor torque expressed in (N.m);
- ω_0 : Synchronous speed equals $2 \cdot f \cdot p \cdot 1$ expressed in (rad s^{-1}); p: is the number of poles pairs.

By taking into account:

$$g = \frac{\omega_0 - \omega}{\omega_0}; \text{ Slip; } \omega \text{ rotorspeed}$$

We shall have:

$$\Delta W_{pt} = \int_0^{t_{pt}} c \cdot \omega_0 \cdot (-\omega) dt \quad (7)$$

The torque c in (7) can be considered according to the equation of motion as (Grassievitch, 1989; Tchilikhine, 1974):

$$c = c_{st} + J \frac{d\omega}{dt} \quad (8)$$

- J : Momentum of inertia and
- c_{st} : Static torque.

Let us consider the case without load.

Since $c_{st} = 0$, the passage from one speed to the other is made with out load.

In that case, according to (7) we shall have:

$$\Delta W_{pt} = \int_0^{t_{pt}} (J \omega_0 \frac{d\omega}{dt} - J \frac{d\omega}{dt}) dt$$

Where:

$$\Delta W_{pt} = \int_{\omega_{in}}^{\omega_{fn}} (J \omega_0 - J \omega) d\omega$$

We have:

$$\begin{aligned} \Delta W_{pt} &= [J \omega_0 \omega]_{\omega_{in}}^{\omega_{fn}} - \left[J \frac{\omega^2}{2} \right]_{\omega_{in}}^{\omega_{fn}} \\ \Delta W_{pt} &= J \omega_0 (\omega_{fn} - \omega_{in}) - J \frac{\omega_{fn}^2 - \omega_{in}^2}{2} \end{aligned}$$

After transformation of this last expression we find:

$$\Delta W_{pt} = J \frac{\omega_0}{2} (g_{in}^2 - g_{fn}^2) \quad (9)$$

The first expression gives us the losses during direct starting without load:

$$\Delta W_{w1} = J \frac{\omega_0^2}{2} \quad (10)$$

The expression between brackets of (9) is used during the passage from a speed to the other. For the starting the initial and final slip are:

$$g_{in} = 1; g_{fn} = 0$$

LOSSES OF THE STARTING IN LINEAR RAMP MODE

A frequency converter is used in the direct linear ramp starting. In Fig. 1 we present a rectifier with constant output voltage followed by a frequency inverter supplying an output with a variable frequency and tension according to a control function $u/f = \text{constant}$ (with a constant electromagnetic flux) (Kataoka *et al.*, 1993; Mohaddam and Butz, 1994; Guy and Guy, 1997; Deform, 2006).

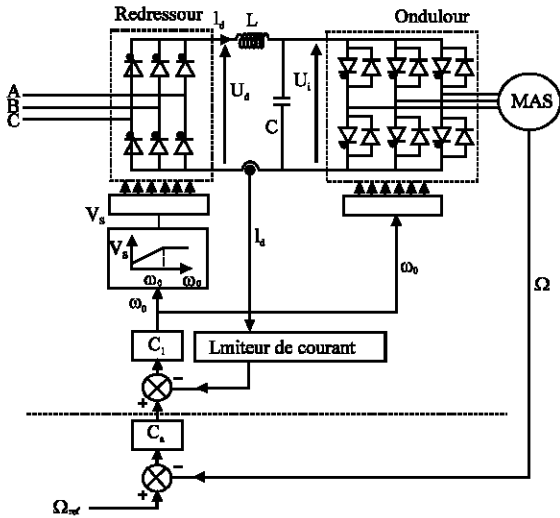

Fig. 1: Frequency converter basic bloc diagram (Defornel, 2006; Bose, 1989)

For the linear characteristics which are more practical, Fig. 2:

The motor torque is given by:

$$c = c_d \left(1 - \frac{\omega}{\omega_0}\right) \quad (11)$$

Where c_d : Starting torque expressed in Newton meter (N.m).

Lets put $\dot{\omega}_0 = \dot{\omega}_0 t$ in (11), ($\dot{\omega}_0$ acceleration [rd s⁻²]) in this case the motion equation becomes:

$$c_d \left(1 - \frac{\omega}{\omega_0}\right) - c_{st} = J \frac{d\omega}{dt} \quad (12)$$

By taking into account the expression (10)

$$T_M \frac{d\omega}{dt} + \omega = \xi_0 t - \Delta\omega_{st} \quad (13)$$

where

$$\Delta\omega_{st} = \frac{c_{st}}{c_d} \omega_0$$

Static speed drop without no load starting $\dot{\omega}_{st} = 0$

$$T_M = J \frac{\omega_0}{c_d}$$

Motor mechanical time constant. The solution is found to be in the form of an addition of 2 components (Grassievtch, 1989):

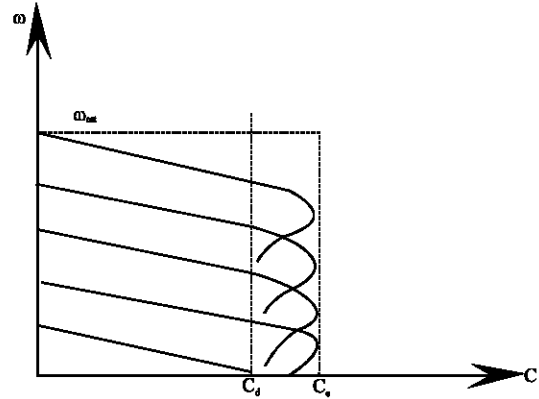

Fig. 2: Mechanical characteristics of the induction motor

$$\begin{aligned} &\text{free } \omega_1 \text{ and forced } \omega_f \\ &\omega = \omega_1 + \omega_f \end{aligned} \quad (14)$$

By taking into account the equality:

$$\frac{d\omega_f}{dt} = \frac{d\omega_0}{dt}$$

We can obtain the forced component, according to the expression (14) of no load starting

$$\xi_0 T_M + \omega_r = \xi_0 t \quad (15)$$

Where

$$\omega_r = \xi_0 t - \xi_0 T_M \quad (16)$$

That means we will have a delay of $\dot{\omega}_0 T_M$ of the forced speed with respect to the no load speed variation $\dot{\omega}_0$ (Fig. 3). The free component in Eq. 14, can be determined provided that the straight part of (13) is equal to zero

$$\dot{\omega}_1 = A e^{-\omega/T_M}$$

Where

A : Integration constant that could be found from the initial conditions. For the starting process.

$$\dot{\omega}_{in} \text{ for } t = 0$$

According to Eq. 14-16 for $t = 0$

$$0 = A - \xi_0 T_M$$

Thus $A = \dot{\omega}_0 T_M$

What makes the free component equals to:

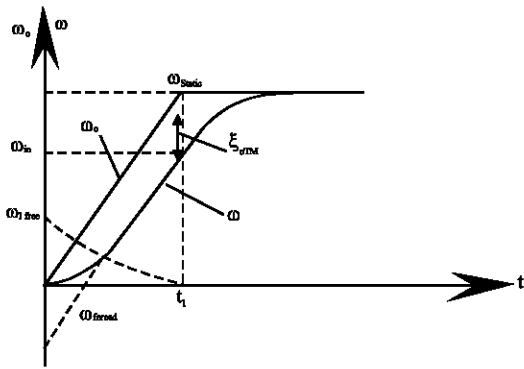

Fig. 3: Variation in linear ramp of $\omega_0 = f(t)$

$$\omega_1 = \xi_0 T_M e^{-t/T_M} \tag{17}$$

The speed final expression from Eq. 11, 13 will be:

$$\omega = \xi_0 t - \xi_0 T_M (1 - e^{-t/T_M}) \tag{18}$$

In Fig. 3 we represent the free and forced components by discontinues curves if $t > t_1$ (Grassievitch, 1989; Tchilikhine, 1974) the speed will vary according to the classical equation:

$$\omega = \omega_{st} (\omega_{in} - \omega_{st}) e^{-t/T_M} \tag{19}$$

In this case ω_{in} corresponds to the speed ω for $t = t_1$. That means the possibility of dividing the starting process into two parts:

First part where $t < t_1$:

$$\omega(t) = \xi_0 t - T_M \xi_0 (1 - e^{-t/T_M}) \tag{20}$$

In that case, the mechanical linear characteristics are given by the expression:

$$c = c_d (1 - e^{-t/T_M}) \tag{21}$$

The second part, where $t > t_1$

$$\omega(t) = \omega_{st} + (\omega_{in} - \omega_{ost}) e^{-(t-t_1)/T_M} \tag{22}$$

the same thing for the characteristics

$$c = c_d e^{-(t-t_1)/T_M} \tag{23}$$

The losses are determined, during the starting process, according to the expression of the type (7).

$$\Delta W_{pt} = \int_0^{t_{p,t}} c(\omega_0 - \omega) dt \tag{24}$$

By assuming the transient process time $t_{p,t} \gg T_M$ and neglecting the free component, ω_1 we obtain

$$\Delta W_{pt} = \int_0^{t_{p,t}} J \xi_0 T_M dt \tag{25}$$

Since

$$c = J \frac{d\omega}{dt} = J \xi_0 \text{ and } \omega_0 - \omega = \xi_0 T_M$$

the solution of Eq. 25, gives us:

$$\Delta W_{p,t} = \frac{J \omega_{st}^2}{2} \cdot \frac{2 \cdot T_M}{t_1} \tag{26}$$

ω_{st} : Static speed (permanent)

We have obtained the very important result.

The comparison between Eq. 26 and 10 shows that the energy losses during linear ramp starting process could be reduced by the decrease of the momentum of inertia or by the increase of the ramp time t_1 .

The case of the Eq. 26 represents a paradox:

- The increase of the ramp time of frequency variation gives the decrease of the energy losses.
- The increase of the ramp time of frequency variation gives also a decrease in motor starting process time response.

The answer to this called paradox would be a compromise to be determined. This compromise could be determined during the electrical control elaboration step. the electrical control elaboration step takes into account the imposed conditions by the technological process and the driven mechanism.

Simulation: According to the mathematical model (Guy and Eddie, 2000; Haiter and Carron, 1994; Baghli, 2005; NORME, 1989) of the motor (not present here), we simulated the machine to be able to know the evolution of the immediate current of starting for both cases (Fig. 4 and 5).

We notice: For the direct starting: the current is very strong and accompanied with many oscillations. For the indirect starting up: The current is reduced and fewer oscillations.

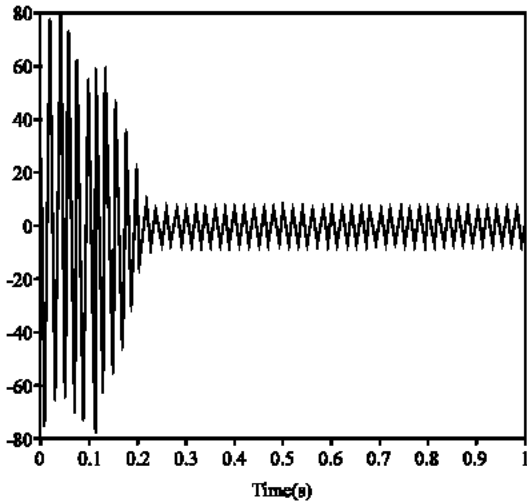

Fig. 4: Immediate, simulated current, of direct starting

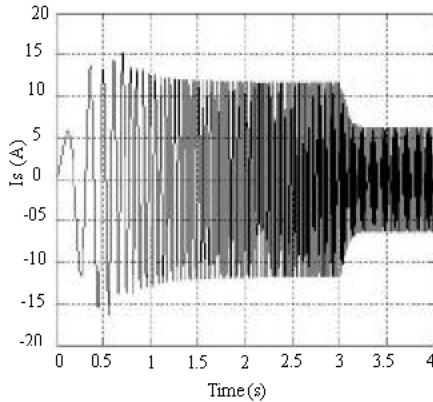

Fig. 5: Immediate, simulated current, of indirect starting in linear ramp mode

PRACTICAL TESTS RESULTS

We have made experimental tests (Grellet, 1989; NORME, 1989), on an motor with the following characteristics:

- Nominal Power $P_{nom} = 2.2 \text{ kW}$
- Nominal Tension $U_{nom} = 190/330\text{V}$
- Nominal current $I_{nom} = 11.5/6.6\text{A}$
- Stator phase resistance $R_s = 1.65 \cdot$
- Stator phase Inductance $L_s = 0.3\text{H}$

These tests allowed us the take of curves It must be noticed that in that case the characteristics (Fig. 5 and 6) instantaneous currents of direct and indirect starting by means of an memory oscilloscope.

Figure 6 and 7 are more or less like the ones we got in the simulation.

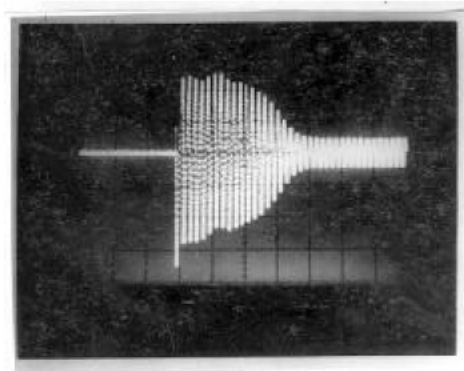

Fig. 6: Measured instantaneous current for direct starting of the motor

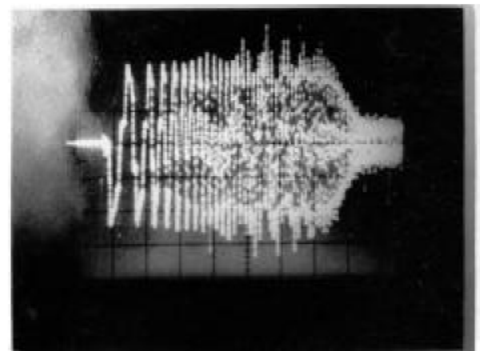

Fig. 7: Measured instantaneous current for indirect starting of the motor

With respect to the energy losses the measured results give:

- For the direct starting the energy losses are equal:
 - $W_{p,t} \cdot 500 \text{ Joules}$
- For the starting in linear ramp mode (indirect starting) Where $\frac{2T_M}{t_1} \approx 0.25$ the energy losses are estimated to:
 - $W_{p,t} \cdot 180 \text{ Joules}$

It must be noticed that in that case the energy losses are not 4 times lower than those during the direct starting.

CONCLUSION

When we use the frequency regulation, the energy losses decrease considerably. Since in reality, the speed regulation is made without any load.

The operational speed is determined by the mechanical characteristic stiffness which does not change practically during the frequency regulation.

The frequency regulation is done by the simultaneous variation of frequency and voltage according to the predetermined rules of the driven mechanism properties.

When we use the frequency regulation the starting current is reduced as well as its oscillations.

The starting of the induction motor with linear ramp mode reduces the losses which are inversely proportional to the ramp time. In this case the starting time increases but the time response of the electrical control loop increases.

The choice of the linear ramp time is done according to the driven technologic process requirement.

REFERENCES

- Baghli, L., 2005. Modélisation et Commande de la machine Asynchrone Université Henry Poincaré, Nancy; IUFM de Lorraine UHP France.
- Bose, B.K., 2005. Power Electronics and AC Drives. Prentice HALL, New Jersey.
- Defornel, B., 2006. Machines asynchrones/Commande par contr le scalaire Institut National de Polytechnique de Toulouse France.
- Grassievitch, V., 1989. Moteurs Electriques, Aide mémoire de commande électrique automatisée. Energy Moscou.
- Grellet, G., 1989. Pertes dans les machines électriques tournantes Traité de L'electrotechnique de l'encyclopedie Rubrique Machines Electrique.
- Guy Sturtzer and Eddie Smigiel, 2000. Modélisation and commande des moteurs triphasés. Technosup, France.
- Guy, G. and L. Guy, 1997. Actionneurs Electriques, principes, modèles, commande France.
- Kataoka, J., Y. Sato and A. Bendiab Abdallah, 1993. A novel Volts/Hertz Control method for induction motor to improve the torque characteristics in the low speed range Brington, England.
- Mohaddam, F. and B. Butz, 1994. Réglage et commande en U/f statorique variables de servomoteurs asynchrones, EPE Chapter Symposium EPFL, Lausanne-Suisse.
- NORME NFC 51-112-UTE-PARIS, 1989. Méthode pour la détermination des pertes et rendement des machines électriques tournantes à partir d'essaisN. NFC 51 Revue France.
- Rini Nur Hassanah, 2005. A contribution to energy saving in induction motors, these No. 3255 Ecole Polytechnique Fédérale de Lausanne.
- Tchilikhine, M., 1974. Cours de Commande Electrique Edition.
- Wided De Ghaichia, 2001. Conception et dimensionnement de moteurs asynchrones de petites et moyennes puissances. Thèse sciences technique, Ecole Polytechnique Fédérale de Lausanne.