

## A Survey on Controlled AC Electrical Drives

<sup>1</sup>Nalin Kant Mohanty, <sup>2</sup>Ranganath Muthu and <sup>3</sup>M. Senthil Kumaran

<sup>1</sup>Department of EEE, SRM University, Chennai-603203, India

<sup>2</sup>Department of Electrical and Electronics Engineering,  
SSN College of Engineering, Anna University, India

<sup>3</sup>SSN College of Engineering, Anna University, Kalavakkam, India

---

**Abstract:** This study presents, a review of recently use control of ac electrical machines in electrical drives. A variety of control techniques, different in concept, are described, Direct Torque Control (DTC) with Space-Vector Modulation (DTC-SVM), trends in the DTC-SVM techniques based on neuro-fuzzy logic controllers and Vector control for Slip energy recovery in DFIG is presented. The increasing importance of speed or position sensorless speed and torque control techniques.

**Key words:** Alternating vector Control (AC), Direct Torque Control (DTC), Induction Motor (IM), Synchronous Motor (SM), Switched Reluctance Motor (SRM)

---

### INTRODUCTION

The Induction Motor (IM), is well-known advantages of simple construction, reliability, ruggedness and low cost, has found very wide industrial applications. Furthermore, in contrast to the commutation dc motor, it can be used in an aggressive or volatile environment since there are no problems with spark and corrosion. These advantages, however, are superseded by control problems when using an IM in industrial drives with high performance demands.

IM control methods can be divided into scalar and vector control. The most popular method, known as Field-Oriented Control (FOC) or vector control, has been proposed by Hasse (1972) and Blaschke (1972a) and gives the induction motor high performance. In the vector control the motor equations are transformed in a coordinate system that rotates in synchronism with the rotor flux vector. These new coordinates are called field coordinates. In field coordinates-under constant rotor flux amplitude-there is a linear relationship between control variables and torque. Moreover, like in a separately excited dc motor, the reference for the flux amplitude is reduced in the field-weakening region in order to limit the stator voltage at high speed. Transformation of IM equations in the field coordinates has a good physical basis because it corresponds to the decoupled torque production in a separately excited dc motor. However, from the theoretical point of view, other types of coordinate transformations can be selected to

achieve decoupling and linearization of IM equations. This has originated the methods known as modern nonlinear control (Bodson *et al.*, 1998; Vas, 1998; Taylor, 1994). Marino (1996) have proposed a nonlinear transformation of the motor state variables so that, in the new coordinates, the speed and rotor flux amplitude are decoupled by feedback; the method is called Feedback Linearization Control (FLC) or input-output decoupling.

Sensorless techniques are explain with the methods broadly divided into 2 classes: those using the fundamental properties or model of the machine and those exploiting subsidiary features, often by using SI. Fundamental model methods are widely applicable to the main classes of ac machines used in drives, but are inherently incapable of prolonged working at zero speed. SI methods are capable of zero speed operation, but the properties used are usually machine-specific, limiting the generality of their industrial application. This particularly applies to the IM, which is still preferred for the majority of cases. A lot of research attention. SRMs also require simple switched electronic commutation. They are doubly-salient VR machines (with stator and rotor pole slotting) with pronounced deep slots on both sides of the air-gap and can use single or multiple teeth per stator pole. Simplicity and cheapness being the major features. Understanding and designs have gradually improved over the last 2 decades, with power density being improved by various means, including segmental rotors, which were 1st used to considerably enhance SynR machines, as Mecrow *et al.* (2002).

### TYPES AC MACHINE CONTROL

The advantages of ac drives include robustness, compactness, economy and low maintenance. Variable-frequency ac machine control can be divided into scalar and field oriented or Vector Control (VC).

**Scalar control:** Scalar control is based on steady state relationships; usually only magnitude and frequency are controlled, not space vector orientation. Making terminal voltage magnitude proportional to frequency results in an approximately constant stator flux, this is desirable to maximize capability of the motor. The classical variable frequency V/f scheme is a scalar control based on this principle, with voltage boost at low frequency usually introduced to counteract the larger effect of stator resistance at low speeds. Scalar control, often open-loop apart from stator current monitoring for fault detection, gives an economical drive with good behavior, but transients may not be well controlled. More sophisticated variants can improve behavior, perhaps with better handling of parameter variations, particularly of stator resistance. Buja and Kazmierkowski (2004) describe the evolution of the still widely used scalar control methods and their progression to VC.

**Vector Control (VC):** In VC the instantaneous position of voltage, current and flux space vectors are controlled, ideally giving correct orientation both in steady state and during transients. Coordinate transformations (3 phase to 2 or d-q axes) to new field coordinates are a key component of standard VC, giving a linear relationship between control variables and torque. It is ideally suited to current control via PWM voltage switching. VC can be introduced by considering a dc machine. In a dc drive the rotating commutator acts as both current switch and rotor position sensor. A dc drive is shown in a schematic diagram in Fig. 1, where,  $i_a$  is often chopper controlled. The commutator maintains the main flux and the armature MMF directions to be approximately perpendicular under all operational conditions, illustrated by the vector diagram. This basic arrangement defines the aim of a VC for a high performance ac drive, The electrical torque is shown as the product of magnetic flux linkage and current

$$(T_e \propto \psi i) \quad (1)$$

The VC usually separates current into field and torque producing components. The perpendicular field system makes the relationships between the machine variables simple, in principle. The flux is a function of the field (producing component) or d-axis current, the torque

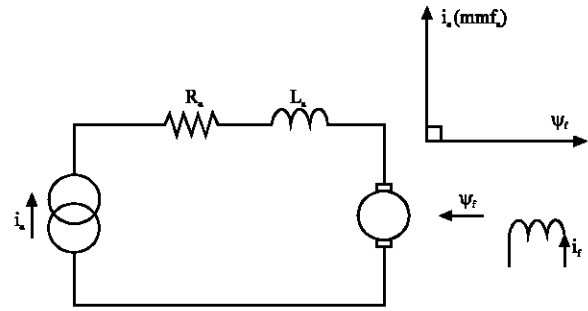

Fig. 1: Flux and MMF in DC drive. er

is proportional to the product of this flux and the torque (producing component) or q-axis current. If the flux is established and can be held constant, the torque response is governed by the current and can be fast and well-controlled. Full advantages of VC are given only if the instantaneous position of the rotor flux vector can be established. The usual IM cast cage rotor aids in robustness and economy, but rotor quantities are not accessible. Two variants of VC are used, direct and indirect. In the direct method the instantaneous rotor position for this flux is found either by sensors, or more usually by estimators, or a combination; Blaschke (1972b) was a pioneer of the approach. Figure 2 shows a basic scheme. Indirect VC for an IM combines a slip calculation with use of rotor position or speed (Blaschke, 1972a). Slip calculation involves the rotor time constant which can vary considerably mainly due to changes in rotor resistance with temperature. This need for rotor position or velocity is most obviously required in an SM such as a brushless PM machine since stator excitation must be synchronous to the rotor. It also applies to an IM drive, although the basic symmetry of the rotor implies only relative velocity is originally needed. A straightforward method is to attach a rotor sensor, e.g., an encoder to measure rotor position or speed and this is still preferred in many cases, but sensorless schemes are gaining ground.

**Direct Torque Control (DTC):** DTC also exploits vector relationships, but replaces the coordinate transformation concept of standard VC with a form of bang-bang action, dispensing with PWM current control (Buja and Kazmierkowski, 2004). In standard VC the q-axis current component is used as the torque control quantity. With constant rotor flux it directly controls the torque. In a standard 3-phase converter, simple action of the 6 switches can produce a voltage vector with 8 states, 6 active and 2 zero. The voltage vector and stator flux then move around a hexagonal trajectory; with sinusoidal

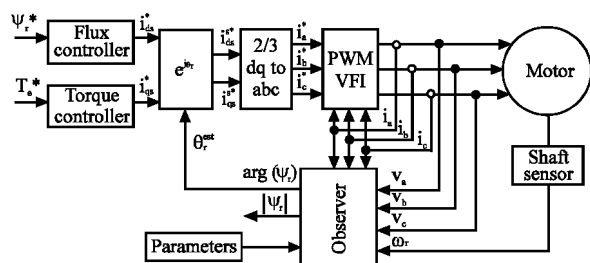

Fig. 2: Basic direct VC scheme with use of rotor position or speed

PWM this becomes a circle. With either, the motor acts as a filter, so rotor flux rotates continuously at synchronous speed along a near-circular track. In DTC the bang-bang or hysteresis controllers impose the time duration of the active voltage vectors, moving stator flux along the reference trajectory and determining duration of the zero voltage vectors to control motor torque. At every sampling time the voltage vector selection block chooses the inverter switching state to reduce the flux and torque error. Depending on the DTC switching sectors, circular or hexagonal stator flux vector path schemes are possible. DTC has these features compared to standard VC (Buja and Kazmierkowski, 2004):

- No current control loops so current not directly regulated
- Coordinate transformation not required
- No separate voltage PWM
- Stator flux vector and torque estimation required

Depending on how the switching sectors are selected, 2 different DTC schemes are possible. One, proposed by Takahashi and Noguchi (1986), operates with circular stator flux vector path and the second one, proposed by Depenbrock (1988), operates with hexagonal stator flux vector path (Terzic and Jadric, 2001). There are different types of DTC schemes as (Buja and Kazmierkowski, 2004):

- Switching-table based DTC (ST-DTC)
- Direct Self Control scheme (DSC)
- Constant switching frequency DTC scheme

Basically, the DTC strategies operating at constant switching frequency can be implemented by means of closed-loop schemes with PI, predictive/dead-beat or Neuro-Fuzzy (NF) controllers. The controllers calculate the required stator voltage vector, averaged over a sampling period. The voltage vector is finally synthesized by a PWM technique, which in most cases is the Space-Vector Modulation (SVM). Therefore, differently from the

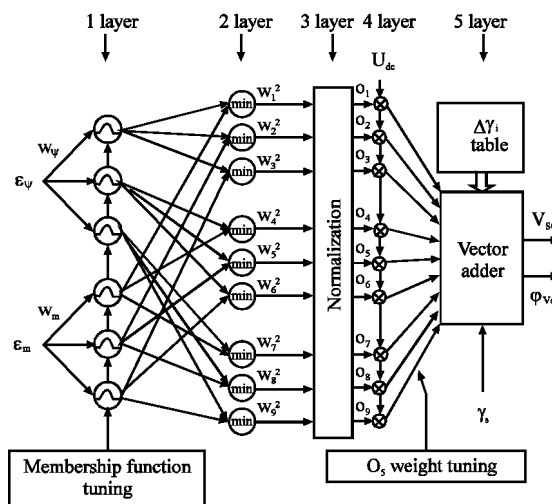

Fig. 3: Neuro fuzzy DTC-SVM block diagram

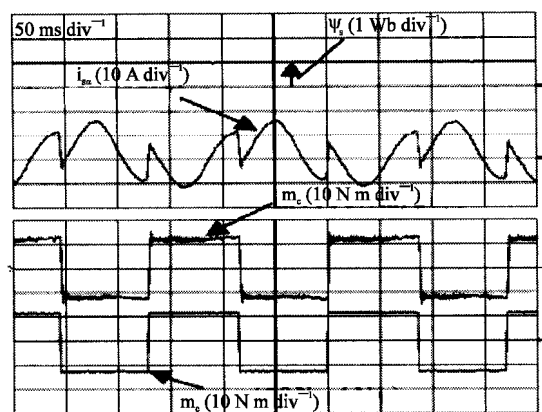

Fig. 4: Torque tracking performance

conventional DTC solution, in a DTC-SVM scheme the switching harmonics are neglected in the control algorithm.

In the last decade a fast development of artificial-intelligence based controllers has been observed. They have expanded in the area of power electronics and drive control (Bose, 2001; Kazmierkowski and Orłowska-Kowalska, 2002; Kazmierkowski *et al.*, 2002; Vas, 1999). The combination of fuzzy logic and artificial neural networks has been proved to be powerful as it offers all the advantages of both techniques. The initial structure of the controllers is commonly built up using the human expert knowledge (Acarney and Watson, 2006; Xu and Rahman, 2007; Mir *et al.*, 1994a, b; Mir and Elbuluk, 1995; Vas, 1999; Xia and Oghanna, 1997). A controller based on Adaptive NF Inference System (ANFIS) for voltage space-vector generation has been

proposed by Grabowski *et al.* (2000). It combines fuzzy logic and artificial neural networks for decoupled flux and torque control.

In the Neuro Fuzzy DTC-SVM scheme, shown in Fig. 3, the error signals  $\epsilon_\phi$  and  $\epsilon_m$  are delivered to the NF controller, which is also entered by the actual position ( $\gamma_s$ ) of the stator flux vector. The NF controller determines the stator voltage command vector in polar coordinates ( $V_c = V_{sc} \cdot \psi_{vc}$ ) for the SVM block. The scheme is characterized by a simple self-tuning procedure and good steady-state and dynamic performance Fig. 4.

### VECTOR CONTROL FOR SLIP POWER RECOVERY IN DFIG

Figure 5 shows a configuration employing a Doubly-Fed Induction Generator (DFIG) and a power electronic converter that connects the rotor winding to the grid directly. With this configuration, it is possible to extend the speed range further without affecting the efficiency. By this scheme, the generator can be operated as a generator at both sub-and super synchronous speed and the speed range depends only on the converter ratings. The reason for speed control without loss of efficiency is that slip power can be fed back to the grid by the converter instead of being wasted in the rotor resistance. Note that the power rating of the power converter is  $sP_{nom}$ , where 's' is the maximum possible slip and  $P_{nom}$  is the nominal power of the machine. The rotor slip (s) can be positive or negative because the rotor power can be positive or negative, due to the bidirectional nature of power electronic converter. For example, if the power rating of the converter is 10% of the power rating of the generator, the speed control range is from 90-110% of the synchronous speed. It means at 110% speed,  $s = -0.1$  and power is fed from the rotor to the grid, whereas at 90% speed, the slip is  $s = +0.1$  and 10% of the power is fed from the grid to the rotor through the converter. With these attributes, i.e., a larger control range and smaller losses, the configuration in Fig. 5 is more attractive than a Normal Induction motor control.

The system suffers from the inevitable need for slip rings, which may increase the maintenance of the system and decrease its reliability. The 2 inverters-the grid side inverter and the rotor side inverter-in Fig. 5 can be controlled independently and by a proper control the power factor at the grid side can be controlled to unity or any desired value. By more sophisticated control schemes the system can be used for active compensation of grid-side harmonics.

The recent Developments on the converter design is to use a Matrix Converter instead of a Back to back converter in slip recovery scheme with the advancement of more sophisticated Microcontrollers and FPGA.

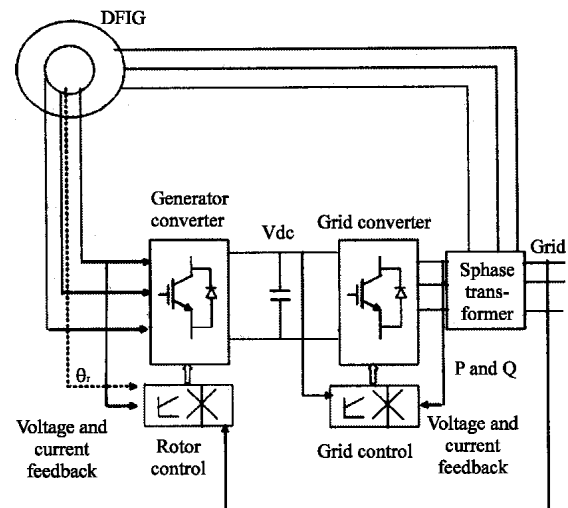

Fig. 5: Block diagram of slip recovery scheme

### SENSORLESS CONTROL METHOD

**General overview:** There is intensive research worldwide devoted to sensorless methods. Motor drives without a speed or position sensor have received much research attention in recent years, both for IMs (Holtz, 2002, 2006), and PM brushless types (Acarnley and Watson, 2006). Such techniques typically measure stator quantities, usually current, directly via existing transducers normally present in the inverter and voltage, although not often with a direct measurement. SI methods are also used. Figure 6 shows a typical schematic of a sensorless scheme.

Advantages of such "sensorless" schemes include (Holtz, 2002, 2006) more compact drive with less maintenance, no cable to machine transducers, easier application particularly to existing machines, reduced electrical noise, transducer cost avoided and suitable for hostile environments, including temperature.

### Model-based estimation methods

**Fundamental basis-flux linkage:** Sensorless control of both IM and PM machines can use fundamental model-based estimation methods, these fundamental model-based methods usually describe the machine by d-q axis equations, where sinusoidal distribution around the air gap is assumed. As this neglects space harmonics, slotting effects, etc., it is often termed a fundamental model. Fundamental models have an inherent limit. As the stator frequency approaches zero the rotor-induced voltage goes to zero and the IM becomes unobservable (Holtz, 2002). Methods are either implemented in open-loop form or as closed-loop observers (estimators), making use of the error between measured and estimated quantities to improve their behavior.

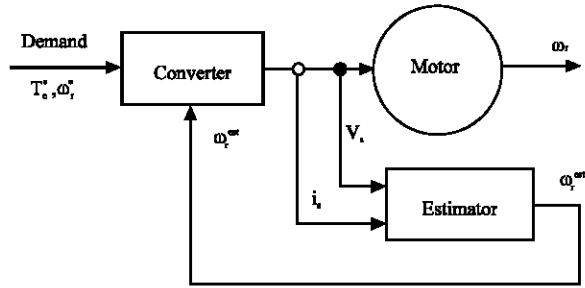

Fig. 6: Block diagram of sensorless scheme

The simplest form for the stator voltage equation using the usual symbols would be

$$v_s = R_s i_s + \frac{d\psi_s}{dt} \quad (2)$$

The stator flux linkage  $\psi_s$  is a function of speed and frequency, but its rate of change drops to zero at zero frequency. An IM appears to be purely resistive at the stator terminals at sufficiently low frequency/speed. Since, flux is a key element in accurate sensorless control Eq. 2 shows the requirement from terminal quantities when recast into integral form

$$\varphi_s = \int_0^t (v_s - i_s R_s) dt \quad (3)$$

The signals used in Eq. 3 will have noise and disturbances on the measured values, degrading accuracy. Digital measurement implies noise and quantization, while drift and offset arise from analog transducers. These effects and the lack of a perfect integrator, limit the performance obtained. How well this integration can be implemented is a main factor in the low-speed applicability of model-based methods. The integrator can be replaced by a LPF Inaccurate reference model parameters, mainly stator resistance, also limit low speed results.

There is of course considerable overlap with combinations of methods being used. Methods range in complexity from the simpler MRAS, through KF and EKF forms, as well as other observer or estimator schemes. Conventional sensor-based feedback control is still being actively developed, sometimes augmented by estimation.

**PM sensing using motional EMF:** Practical difficulties in the use of motional EMF sensing occur since the windings carry rapidly changing currents, giving substantial inductive effects. Since, the EMF is zero at zero speed, a finite speed threshold must operate. A

particular problem in an SM such as the PM machine is that starting is also position dependant, so rotor position and magnetic field polarity are ideally required to avoid a starting transient which may be in reverse. Special arrangements, perhaps an open-loop ramp, may be made for starting (Acarney and Watson, 2006), with parameters chosen to suit drive and load. Simple motional EMF sensing schemes have limitations:

- Sensing is not possible at low speeds
- Filtering and phase shift gives a limited dynamic range
- Upper limit on the useful speed range when assumed rapid decay of switched off current no longer happens
- Phase EMF measured, for a star connection an extra lead is needed

**PM sensing using inductance variation:** Where inductance is a function of rotor position, then position can be deduced from winding current and its rate of change. This applies even at stand-still, where motional EMF is zero. There are problems: with surface-mounted magnets, inductance variation with position is only from magnetic saturation; at higher speed motional EMF dominates; inductance variation has 2 cycles per electrical cycle of the PMM, giving a sensed position ambiguity (Acarney and Watson, 2006). Shi *et al.* (2006) use an adaptive controller for a sensorless PMM drive using maximum torque control. The current slope change and rotor saliency give position estimation with back EMF compensation. This gives good robustness to inertia and friction with an estimation error near  $\pm 1^\circ$ , a  $0-5 \text{ r min}^{-1}$  step is shown at inertia  $4.5 \times$  rotor (Bose, 1986).

**MRAS:** The usual MRAS estimates speed using 2 different machine models, one being speed dependant (Holtz, 2006; Blaschke, 1972b). Differences between the models can be used to reduce the error in the speed estimate, often with an internal proportional-integral controller. The basic MRAS block diagram is drawn as Fig. 7. How well the ideal integrator in the reference model is approximated is one defining factor for performance. Good behavior with an IM above 2 Hz stator frequency was reported by Schauder (1992) in pioneering industrial based developments. Ohtani *et al.* (1992) in early research described a torque MRAS with better behavior. Better independence to motor parameters, In an early comparison Armstrong *et al.* (1997) compared a basic rotor flux MRAS and EKF estimator behavior. The EKF was more resilient to parameter changes, but MRAS is simpler (with a computing complexity ratio of almost 20: 1) and can even be better at low speed. Performance was said to already rival an encoded indirect VC drive.

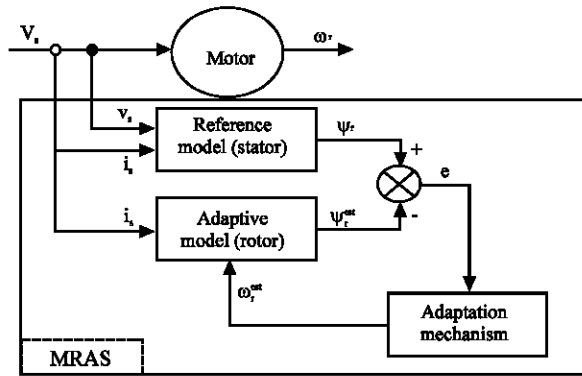

Fig. 7: MRAS speed sensor block diagram

Later developments include parameter adaptation, which is important for low speed behavior. Recently, Rashed *et al.* (2007) report an indirect VC MRAS for rotor flux and stator resistance estimation in a PMM. Operation at  $2 \text{ rad s}^{-1}$  is shown. Cirrincione *et al.* (2006) use a NN predictive adaptive model in a MRAS based IM drive, comparing with an older MRAS scheme.

**KF:** The KF is a well known more advanced technique in signal processing which has been widely applied to drives. This includes IMs for rotor current (and hence rotor flux vector) estimation in direct VC and in EKF form for rotor resistance estimation. Variations in motor parameters, particularly rotor resistance, should ideally be tracked. EKF for rotor resistance, also a reduced order model, was introduced for computational savings (Atkinson *et al.*, 1991). Akin *et al.* (2006) summarizes the drawbacks to a conventional EKF:

**Cost:** Costly calculation of Jacobian matrices.

**Bias:** Biased estimates.

**Dynamics:** Instability due to linearization and erroneous parameters.

**Assume:** White gaussian noise.

**Tuning:** Lack of analytical methods for model covariance selection.

**Observers and other schemes:** As described, closedloop observers can improve robustness against parameter errors and noise. Combinations of MRAS or EKF with adaptation are common, as are other observer-based schemes. Forms used include full order nonlinear and sliding mode observers (Holtz, 2006). SMC has been

widely touted for use in drives as Utkin (1993) has described in a widely cited paper. Barambones *et al.* (2007) apply an integral SMC to an IM based on VC theory, with parameter robustness tested with 20% variations, but with undemanding speed stepping tests from about  $800\text{-}1200 \text{ r min}^{-1}$ , centered on  $1000 \text{ r min}^{-1}$ . Various parameter tracking methods have been deployed in the past, as reviewed by Toliyat *et al.* (2003). These methods included resistance identification using an observer, directly by MRAS, or using reactive power which was claimed to give good sensitivity and dynamic response (Holtz, 2006). Fundamental model observer based methods are widely applied to PMMs, with recent research said to concentrate on closed-loop methods (Acamley and Watson, 2006). Such estimators may include a simple mechanical system model which requires details of mechanical parameters.

Using a speed adaptive sliding mode observer zero and very low performance is demonstrated and claimed to be the lowest without SI; sensitivity to parameter changes were simulated, showing insensitivity to rotor resistance. Zero speed full load operation is said to be stable and accurate. Inverter nonlinearity compensation and stator resistance adaptation improved behavior. A rather large total inertia was used, about  $10\times$  that of the IM rotor (Lascu *et al.*, 2005). Mitronikas and Safacas (2005) describe an improved VC method for an IM drive, using a closed-loop stator flux estimator; rotor speed estimation uses an MRAS. The work is supported by simulations and lightly loaded experimental results. Cirrincione *et al.* (2006) propose an adaptive speed observer for rotor speed based on a new total least-squares neuron for IM drives, using the Luenberger observer equation. Edelbahr *et al.* (2006) used a closed-loop rotor-flux observer based on “extended electromotive force,” inverter nonlinearity compensation and stator resistance adaptation. Bhattacharya and Umanand (2006) propose a flux estimation and stator resistance adaptation method that gives the effect of open integration, but with an error-decaying mechanism to resolve the dc drift problem. Salo and Tuusa (2005) outline a new stator current control method for VC PWM current-source inverter IM drives suitable for single-chip microcontroller implementation and avoiding stator current transducers. Sonnaillon *et al.* (2006) also, address reducing the sensor count with dc-link measurements and an IM model. Adequate performance in closed loop from 0.05 per unit speed is claimed, using scalar V/f at lower speeds. Kadowaki *et al.* (2007) apply secondary flux-based estimation to an actual electric commuter train with an IM rating of 120 kW to give desired adhesion and comfort. Other high power applications include Bonnet *et al.* (2007) with a novel

doubly fed IM control strategy using DTC, suitable for high ratings with inverter economy. Higher speed range operation is addressed by Casadei *et al.* (2007) in a DTC IM, where the flux reference is adjusted by torque error, giving spontaneous flux weakening. Kaboli *et al.* (2007) concentrate on power efficiency improvement by use of flux control methods for loss minimizing. In any SM, rotor position affects behavior. Krishnamurthy *et al.* (2006) address prediction of rotor position for start-up at standstill and rotating conditions for SRMs. This schemes are allowed a wide speed range, including zero; low speeds use pulse injection, while higher speeds use a sliding-mode observer.

**Fundamental model scheme problems:** Low speed operation is the main area where difficulties arise (Holtz, 2006). The problems can include the following:

**Signal acquisition errors:** These are a basic limitation for very low speed operation, minor dc components in the signals used in Acarnley and Watson (2006) can produce substantial offsets in the estimated flux linkage even if a pure integrator could be used.

**Inverter:** The inverter introduces nonlinear dead-time effects; very good performance at low speed will require compensation. Further, nonlinearities come from power device forward voltage drops and may also require modeling. Additional effects include the sensitivity of voltage drop and dead time compensation to the exact point of current reversal. Estimating the stator voltage vector from the PWM index can then become inaccurate.

**Model parameters:** Parameters can be determined in a commissioning phase, either offline or using the inverter to self test, aiding accuracy of estimation. This might include finding a good initial value of the stator resistance using a dc test.

### SENSORLESS CONTROL THROUGH SI AND PARASITIC EFFECTS

In SI methods the machine is injected with extra, low level signals usually at high frequency. The much higher frequency and low magnitude of the injected signals result in the fundamental behavior of the machine being little changed. The injected signals may be periodic or alternating in a particular spatial direction. These signals are modulated by the orientations of the machine asymmetries and are then processed and demodulated to yield the required measurement. Such asymmetries occur more naturally in SMs. According to Giaouris and Finch (Marino, 1996), wavelet transforms are best

deployed in precisely such challenging situations, where useful components exist at widely spread and varying frequencies and the bandwidths are uncertain. Caruana *et al.* (2006) use HF SI techniques for zero-low frequency VC of a standard closed slot IM, with compensating and filtering methods in addition to a KF with  $\pm 30 \text{ r min}^{-1}$  reversal test results. More novel approaches include that of Wang *et al.* (2006), who present a speed-estimation technique using SI and the standard smooth air gap IM model, combined with an MRAS. This is claimed to work over a wide speed range, including zero speed and fundamental frequency, provided the moment of inertia is sufficiently high, although this is not quantified.

### CONCLUSION

Controlled electric drive applications using ac electrical machines have been reviewed. The types and properties of the major types of ac electrical machines were first summarized since machine characteristics considerably influence the control methods needed. Control techniques which are being applied to make ac drives a rapidly growing area. Speed or position sensorless techniques are of increasing importance.

Their features are, splitting techniques into fundamental model-based and SI and parasitic techniques. Model-based methods have long been available, The performances achievable from different methods will be applied to more demanding practical applications in industry with very good static and dynamic behavior.

### REFERENCES

- Acarnley, P.P. and J.F. Watson, 2006. Review of position-sensorless operation of brushless permanent-magnet machines. IEEE. Trans. Ind. Elect., 53 (2): 352-362.
- Akin, B., U. Orguner, A. Ersak and M. Ehsani, 2006. Simple derivative-free nonlinear state observer for sensorless AC drives. IEEE/ASME Trans. Mechatronics, 11 (5): 634-643.
- Armstrong, G.J., D.J. Atkinson and P.P. Acarnley, 1997. A comparison of estimation techniques for sensorless vector controlled induction motor drives. In: Proc. IEEE. Int. Conf. Power Elect. Drive Syst., May 26-29, 1: 110-116.
- Atkinson, D.J., P.P. Acarnley and J.W. Finch, 1991. Observers for induction motor state and parameter estimation. IEEE. Trans. Ind. Appl., 27 (6): 1119-1127.
- Barambones, O., A.J. Garrido and F.J. Maseda, 2007. Integral slidingmode controller for induction motor based on field-oriented control theory. Proc. IET Control Theory Appl., 1 (3): 786-794.

- Bhattacharya, T. and L. Umanand, 2006. Improved flux estimation and stator-resistance adaptation scheme for sensorless control of induction motor. *Proc. Inst. Elect. Eng.-Electric Power Appl.*, 153 (6): 911-920.
- Blaschke, F., 1972a. The principle of field orientation as applied to the new transvector closed loop control system in a PWM inverter induction motor drive. *Siemens Rev.*, 39 (5): 217-220.
- Blaschke, F., 1972b. The principle of field-orientation as applied to the transvector closed-loop control system for rotating-field machines. *Siemens Rev.*, 34: 217-220.
- Bodson, M., J. Chiasson and R. Novotnak, 1998. High performance induction motor control via input-output linearization. *IEEE. Control Syst. Mag.*, 14: 25-33.
- Bonnet, F., P.E. Vidal and M. Pietrzak-David, 2007. Dual direct torque control of doubly fed induction machine. *IEEE. Trans. Ind. Elec.*, 54 (5): 2482-2490.
- Bose, B.K., 1986. *Power Electronics and AC Drives*, Englewood Cliffs, N.J., Prentice Hall.
- Bose, B.K., 2001. *Modern Power Electronics and AC Drives*. Englewood Cliffs, NJ: Prentice-Hall.
- Buja, G.S. and M.P. Kazmierkowski, 2004. Direct torque control of PWM inverter-fed AC motors: A survey. *IEEE. Trans. Ind. Electron.*, 51 (4): 744-757.
- Caruana, C., G.M. Asher and M. Sumner, 2006. Performance of HF signal injection techniques for zero-low-frequency vector control of induction machines under sensorless conditions. *IEEE. Trans. Ind. Elec.*, 53 (1): 225-238.
- Casadei, D., G. Serra, A. Stefani, A. Tani and L. Zarri, 2007. DTC drives for wide speed range applications using a robust flux-weakening algorithm. *IEEE. Trans. Ind. Elec.*, 54 (5): 2451-2461.
- Cirrincione, M., M. Pucci, G. Cirrincione and G.A. Capolino, 2006. An adaptive speed observer based on a new total least-squares neuron for induction machine drives. *IEEE. Trans. Ind. Appl.*, 42 (1): 89-104.
- Depenbrock, M., 1988. Direct self control of inverter-fed induction machines. *IEEE. Trans. Power Elec.*, 3: 420-429.
- Edelbaher, G., K. Jezernik and E. Urlep, 2006. Low-speed sensorless control of induction machine. *IEEE. Trans. Ind. Elec.*, 53 (1): 120-129.
- Grabowski, P.Z., M.P. Kazmierkowski, B.K. Bose and F. Blaabjerg, 2000. A simple direct-torque neuro-fuzzy control of PWM-inverter-fed induction motor drive. *IEEE. Trans. Ind. Elec.*, 47: 863-870.
- Hasse, K., 1972. Drehzahlregelverfahren für schnelle umkehrantrieb mit stromrichtergespeisten asynchron-kurzschlusslaufermotoren. *Regelungstechnik*, 20: 60-66.
- Holtz, J., 2002. Sensorless control of induction motor drives. *Proc. IEEE.*, 90 (8): 1359-1394.
- Holtz, J., 2006. Sensorless control of induction machines- With or without signal injection? *IEEE. Trans. Ind. Elec.*, 53 (1): 7-30.
- Kaboli, S., M.R. Zolghadri and E. Vahdati-Khajeh, 2007. A fast flux search controller for DTC-based induction motor drives. *IEEE. Trans. Ind. Elec.*, 54 (5): 2407-2416.
- Kadowaki, S., K. Ohishi, T. Hata, N. Iida, M. Takagi, T. Sano and S. Yasukawa, 2007. Antislip readhesion control based on speed-sensorless vector control and disturbance observer for electric commuter train-Series 205-5000 of the East Japan Railway Company. *IEEE. Trans. Ind. Elec.*, 54 (4): 2001-2008.
- Kazmierkowski, M.P. and T. Orłowska-Kowalska, 2002. ANN Based Estimation and Control in Converter-fed Induction Motor Drives. In: Ovaska, S.J. and L. Sztandera (Eds.). *Soft Computing in Industrial Electronics*. Heidelberg, Germany: Physica Verlag, pp: 45-94.
- Kazmierkowski, M.P., R. Krishnan and F. Blaabjerg, 2002. *Control in Power Electronics*. San Diego, CA: Academic.
- Krishnamurthy, M., C.S. Edrington and B. Fahimi, 2006. Prediction of rotor position at standstill and rotating shaft conditions in switched reluctance machines. *IEEE. Trans. Power Elec.*, 21 (1): 225-233.
- Lascu, C., I. Boldea and F. Blaabjerg, 2005. Very-low-speed variable-structure control of sensorless induction machine drives without signal injection. *IEEE. Trans. Ind. Appl.*, 41 (2): 591-598.
- Marino, R., 1996. Output feedback control of current-fed induction motors with unknown rotor resistance. *IEEE. Trans. Control Syst. Technol.*, 4: 336-347.
- Mecrow, B.C., J.W. Finch, E.A. El-Kharashi and A.G. Jack, 2002. Switched reluctance motors with segmental rotors. *Proc. Inst. Elect. Eng. Elect. Power Appl.*, 149 (4): 245-254.
- Mir, S.A., D.S. Zinger and M.E. Elbuluk, 1994a. Fuzzy controller for inverter fed induction machines. *IEEE. Trans. Ind. Appl.*, 30: 78-84.
- Mir, S., M.E. Elbuluk and D.S. Zinger, 1994b. PI and fuzzy estimators for the stator resistance in direct torque control of induction motors. In: *Proc. IEEE PESC*, pp: 744-751.
- Mir, S.A. and M.E. Elbuluk, 1995. Precision torque control in inverter-fed induction machines using fuzzy logic. In: *Proc. IEEE PESC*, pp: 396-401.
- Mitronikas, E.D. and A.N. Safacas, 2005. An improved sensorless vector control method for an induction motor drive. *IEEE. Trans. Ind. Elec.*, 52 (6): 1660-1668.



- Ohtani, T., N. Takada and K. Tanaka, 1992. Vector control of induction motor without shaft encoder. *IEEE. Trans. Ind. Appl.*, 28 (1): 157-164.
- Rashed, M., P.F.A. MacConnell, A.F. Stronach and P.P. Acarnley, 2007. Sensorless indirect-rotor-field-orientation speed control of a permanentmagnet synchronous motor with stator-resistance estimation. *IEEE. Trans. Ind. Elec.*, 54 (3): 1664-1675.
- Salo, M. and H. Tuusa, 2005. Vector-controlled PWM current-source-inverterfed induction motor drive with a new stator current control method. *IEEE. Trans. Ind. Elec.*, 52 (2): 523-531.
- Schauder, C., 1992. Adaptive speed identification for vector control of inductionmotors without rotational transducers. *IEEE. Trans. Ind. Appl.*, 28 (5): 1054-1061.
- Shi, D., P.J. Unsworth and R.X. Gao, 2006. Sensorless speed measurement of induction motor using Hilbert transform and interpolated fast Fourier transform. *IEEE. Trans. Instrum. Meas.*, 55 (1): 290-299.
- Sonnaillon, M.O., G. Bisheimer, C. De Angelo, J. Solsona and G.O. Garcia, 2006. Mechanical-sensorless induction motor drive based only on DC-link measurements. *Proc. Inst. Elec. Eng. -Electric Power Appl.*, 153 (6): 815-822.
- Takahashi, I. and T. Noguchi, 1986. A new quick-response and high efficiency control strategy of an induction machine. *IEEE. Trans. Ind. Appl.*, IA-22: 820-827.
- Taylor, D.G., 1994. Nonlinear control of electric machines: An overview. *IEEE. Control Syst. Mag.*, 14: 41-51.
- Terzic, B. and M. Jadric, 2001. Design and implementation of the extended Kalman filter for the speed and rotor position estimation of brushless DC motor. *IEEE. Trans. Ind. Elec.*, 48 (6): 1065-1073.
- Toliat, H.A., E. Levi and M. Raina, 2003. A review of RFO induction motor parameter estimation techniques. *IEEE. Trans. Energy Convers.*, 18 (2): 271-283.
- Utkin, V.I., 1993. Sliding mode control design principles and applications to electric drives. *IEEE. Trans. Ind. Elec.*, 40 (1): 23-36.
- Vas, P., 1998. *Sensorless Vector and Direct Torque Control*. London, U.K. Oxford Univ. Press.
- Vas, P., 1999. *Artificial-Intelligence-Based Electrical Machines and Drives*. New York: Oxford Univ. Press.
- Wang, G., H.F. Hofmann and A. El-Antably, 2006. Speed-sensorless torque control of induction machine based on carrier signal injection and smooth-air-gap induction machine model. *IEEE. Trans. Energy Convers.*, 21 (3): 699-707.
- Xia, Y. and W. Oghanna, 1997. Fuzzy direct torque control of induction motor with stator flux estimation compensation. In: *Proc. IEEE IECON*, 2: 505-510.
- Xu, Z. and F. Rahman, 2007. An adaptive sliding stator flux observer for a direct-torque-controlled IPM synchronous motor drive. *IEEE. Trans. Ind. Elec.*, 54 (5): 2398-2406.