

## Design, Development and Simulation of a Microcontroller Based Automatic Electrical Mains Changeover System

M.N. Islam, H. Akhter and M. Begum

*Electronics Division, Atomic Energy Centre, Bangladesh Atomic Energy Commission,  
P.O. Box No. 164, Dhaka, Bangladesh*

**Key words:** Automatic transfer switch, switching transistors, relays, PIC microcontroller, MPLAB IDE

### Corresponding Author:

M.N. Islam  
*Electronics Division, Atomic Energy Centre, Bangladesh Atomic Energy Commission, P.O. Box No. 164, Dhaka, Bangladesh*

Page No.: 61-64

Volume: 13 Issue 04, 2019

ISSN: 1990-7958

International Journal of Electrical Power and Energy

Copy Right: Medwell Publishing

**Abstract:** Design, development and simulation of an automatic Electrical Mains Changeover System (EMCS) using PIC microcontroller ( $\mu\text{C}$ ) has been presented in this study. The system consists of 18-pin DIP package enhanced flash microcontroller PIC16F84A with 4 MHz crystal used as main processor, two switching transistors, two relays and Low Voltage Power Supply (LVPS). The electrical mains control signal output at RB0 and RB2 of PortB actuate two switching transistors which drive two relays to operate the loads depending on the availability of mains or backup power source. An assembly language program based on MPLAB IDE has been developed to control the operation of the system. The design and verification of the PIC  $\mu\text{C}$  based EMCS in Proteus 7.7 simulation platform has been completed successfully.

## INTRODUCTION

Electrical Mains Changeover System (EMCS) is an Automatic Transfer Switch (ATS) that switches a load between two power sources. Some transfer switches are manual in that case an operator affects the transfer by throwing a switch. While others are automatic and trigger when they sense one of the sources has lost or gained power. No matter what type of power source is selected for backup power protection, a reliable electrical device is needed to automatically sense the unacceptability of the primary power source and transfer the load to the secondary. Although, the backup power source may be functional only when the primary source fails, the transfer switch is the only link between the two power sources (ASCO., 2017). In this regard, researcher aimed at designing and constructing a workable automatic change-over switch with generator starting/shut down functions. This switch turns ON the generator automatically in cases of mains power failure and connects the load to the generator output, alternatively it switches OFF the generator automatically once power is restored and returns the load to the mains power (Ezema *et al.*, 2012). In (Kelechi *et al.*, 2015), design and implementation of a Microcontroller based power change-over switching system with generator shutdown basically disconnects load from its power source and transfers it to a standby power source in the advent of a

power failure. Thereafter, an Automatic Transfer Switch (ATS) for a single phase power generator has been designed to enable the automatic operation and transfer of power supply between a public utility supply and a power generator (Agbetuyi *et al.*, 2011). In the current research, design, development and simulation of a PIC microcontroller ( $\mu\text{C}$ ) based automatic Electrical Mains Changeover System (EMCS) has been presented. The 18-pin DIP Package Enhanced Flash Microcontroller PIC16F84A on the basis of an assembly language program developed in MPLAB IDE actuates the switching transistors which drive the relays to operate the loads depending on the availability of mains or backup power source.

## MATERIALS AND METHODS

Design, development and simulation of an automatic Electrical Mains Changeover System (EMCS) using PIC Microcontroller ( $\mu\text{C}$ ) has been presented in this research. The system consists of the microcontroller PIC16F84A with 4 MHz crystal used as main processor, two switching transistors, two relays and Low Voltage Power Supply (LVPS). Block diagram, schematic diagram, circuit description, functional description and program flowchart for the designed EMCS have been presented accordingly.

**Block diagram:** The block diagram of the Microcontroller based automatic Electrical Mains Changeover System (EMCS) with Mains Sensing, PIC Microcontroller P16F84A, switching transistors and Relays have been shown in Fig. 1.

**Schematic diagram:** Complete simulation model of the  $\mu\text{C}$  based automatic electrical mains changeover system has been shown in Fig. 2. The description of individual circuit has been given.

**Low voltage power supply:** A power supply must provide stable and ripple-free DC output voltage independent of line and load variations (Islam *et al.*, 2012). Therefore, the low voltage power supply is essential for the system and a built-in 5V DC power supply has been used in Proteus 7.7 simulation platform.

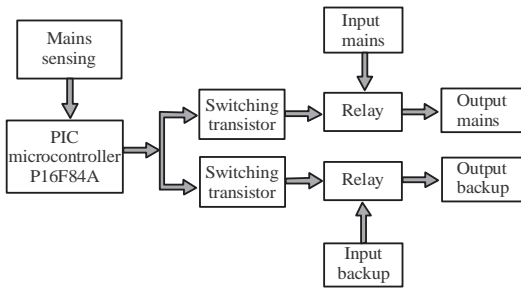

Fig. 1: Shows the block diagram of the  $\mu\text{C}$  based automatic electrical mains changeover system

**Mains sensing circuit:** The mains sensing circuit's function is to detect whether electrical mains present or not consists of a SPST Switch SW1, Variable Resistor RV1, bridge rectifier BR1, filter capacitor C1, discharge Resistor R1, bias Resistor R2, collector Resistor R3, transistor Q1, NOT gate U1 and Resistor R4.

**Mains indicator circuit:** The mains indicator circuit comprises of Resistor R5, R6, Transistor Q2 and LED-RED D1.

**Processor input circuit:** The processor input circuit consists of Resistor R4, the processor PIC16F84A I/O pin RA2 of portA and Resistor R12.

**Processor circuit:** The processor circuit is the heart of the developed system comprises of PIC16F84A 18 pin DIP Package Enhanced Flash Microcontrollers. It consists of CPU, memory for data and program, Special Function Registers (SFRs), General Purpose Registers (GPRs), 2-port (PortA&PortB), active low MCLR, interrupts and free-run timer TMR0 and so on (Islam *et al.*, 2012). An assembly language program has been developed by using MPLAB IDE to control the function of the processor as well as the system.

**Mains switching circuit:** The function of the mains switching circuit is to receive the mains sensing signal from the mains sensing circuit that the electrical mains is

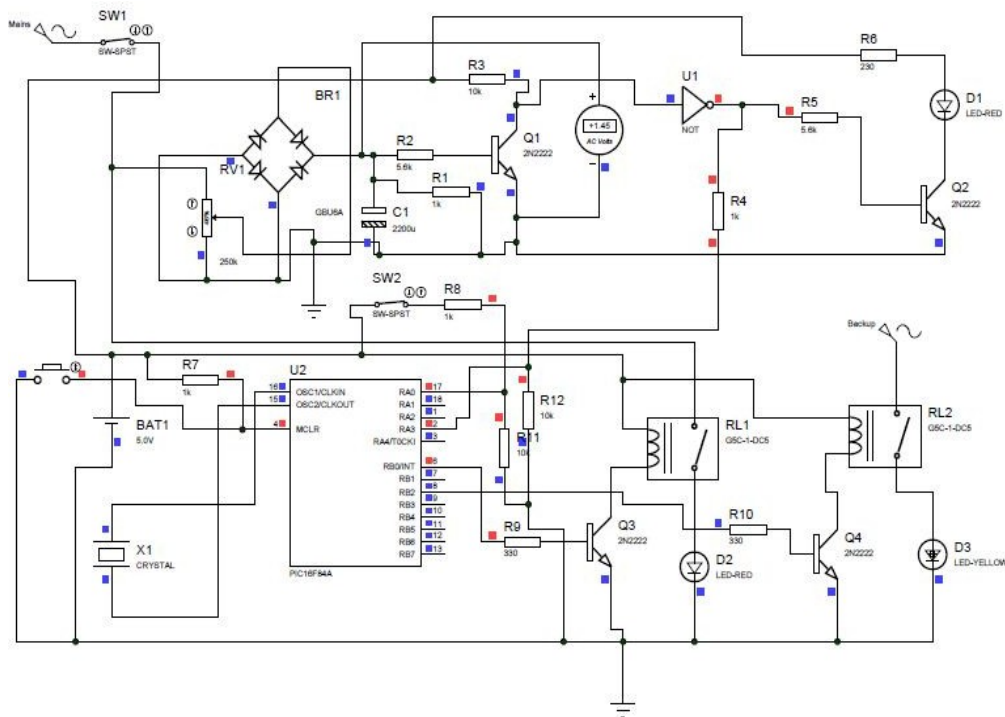

Fig. 2: Complete schematic diagram of  $\mu\text{C}$  based automatic electrical mains changeover system

present. Then the electrical mains control signal output at the processor PIC16F84A I/O pin RB0 of PortB actuate the switching transistor Q3 which drive the relay RL1 to operate the loads connected with mains power source. The following components constitute this circuit such as Resistor R9, Relay RL1, Transistor Q3 and LED-RED D2.

**Backup switching circuit:** The function of the backup switching circuit is to receive the mains sensing signal from the mains sensing circuit that the electrical mains is not present. Then the electrical mains control signal output at the processor PIC16F84A I/O pin RB2 of PortB actuate the switching transistor Q4 which drive the relay RL2 to operate the loads connected with backup power source. The following components constitute this circuit such as Resistor R10, Relay RL2, transistor Q4 and LED-YELLOW D3.

**Start/stop circuit:** The start/stop circuit consists of SPST switch SW2 and Resistor R8 and R11.

**Reset circuit:** The reset circuit has the Microcontroller PIC16F84A I/O pin active low MCLR is tied to Vdd through a Resistor R7 and grounded via a push switch.

## RESULTS AND DISCUSSION

Electricity (energy) plays a major role in socio economic development of a nation with the interests in human, infrastructural, industrial and economic development. In most developing and Least Developed Countries (LDCs) of the world, the supply of electricity for household, commercial and industrial use is highly unstable. This gives rise to the frequent use of alternative sources of power supply to meet up with the energy demands. The introduction of these alternative sources of supply brings forth the challenge of switching smoothly and timely between the mains supply and the alternative sources whenever there is a failure on the mains source (Ezema *et al.*, 2012). Therefore, an automatic Electrical Mains Changeover System (EMCS) based on PIC Microcontroller ( $\mu\text{C}$ ) has been designed, developed and tested in Proteus 7.7 simulation platform. Thus, for finding the solution to switching over to the alternative sources of supply without any delay with unattended operation which effects the change to the alternative sources come the importance of the research work. In this study, at first, the mains sensing circuit detect whether the public utility service, i.e., electrical mains present or not. Depending on availability of mains this circuit generates a signal which is suitable for input into a microcontroller I/O pin. Thereafter, the processor PIC16F84A 18 pin DIP Package Enhanced Flash Microcontroller processes the assembly language program code developed in MPLAB IDE. According to this program  $\mu\text{C}$  generate signals to actuate two switching

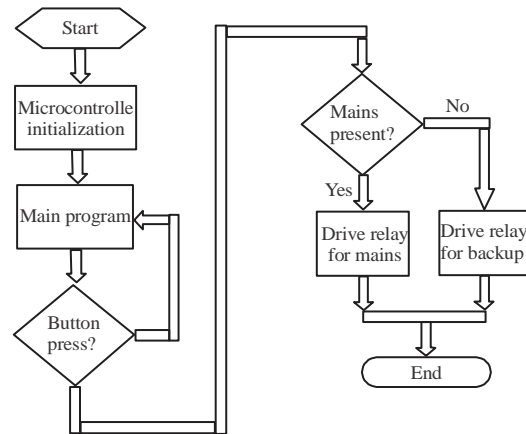

Fig. 3: Shows the program flowchart for the developed system

transistors to drive two relays for mains or back-up power supply. If the mains is present then the system will run the same otherwise it will act for back-up power source as shown in Fig. 3. The system consists of few front panel controls such as start, stop and reset. It has also mains indicator. The power indicator can be added as required.

## CONCLUSION

In this research, design, development and simulation of PIC microcontroller ( $\mu\text{C}$ ) based automatic Electrical Mains Changeover System (EMCS) has been presented. The design and verification of the PIC  $\mu\text{C}$  based Electrical Mains Changeover System (EMCS) in Proteus 7.7 simulation platform has been completed successfully. The designed system is cost effective, simple and reliable in operation. The EMCS has been tested repeatedly and its performance was found satisfactory.

## ACKNOWLEDGEMENT

Researchers wish to express deep gratitude to Mr. Mahbulul Hoq, Chairman (Current-Charge) and member (Physical Science), Dr. Imtiaz Kamal, Member (Planning and Development), Dr. Md. Sanowar Hossain, member (Bio-Science) and Engr. Md. Abdus Salam, member (Engineering), Bangladesh Atomic Energy Commission, Dhaka for their support and cooperation in the research.

## REFERENCES

- ASCO., 2017. ASCO 7000 Series power transfer switch: World class technology for business critical applications. ASCO Power Technologies, Florham Park, New Jersey, USA.
- Agbetuyi, A.F., A.A. Adewale, J.O. Ogunluyi and D.S. Ogunleye, 2011. Design and construction of an automatic transfer switch for a single phase power generator. Int. J. Eng. Sci., Vol. 3, No. 4.

- Ezema, L.S., B.U. Peter and O.O. Harris, 2012. Design of automatic change over switch with generator control mechanism. *Acad. Res. Int.*, 3: 125-130.
- Islam, M.N., A.I. Bhuian, M. Kamal, K. Asaduzzaman and M. Hoq, 2013. Design and development of a 6-digit microcontroller based nuclear counting system. *Int. J. Sci. Res. Manage. (IJSRM.)*, 1: 346-351.
- Islam, M.N., F. Akter, K. Asaduzzaman, M.A.S. Haque and M.S. Islam, 2012. Design, fabrication and performance study of a low cost high voltage power supply. *Nucl. Sci. Appl.*, 21: 7-9.
- Kelechi, C.E., O.K. Henry, N. Uchenna and E. Amaka, 2015. Design and implementation of a microcontroller based power change-over switching system with generator shutdown. *J. Multidiscip. Eng. Sci. Technol.*, 2: 2184-2189.