

## Study on Modifying HVDC Circuit Breaker using Cassie Breaker

Mahmoud Ahmed Saad

*Department of Power and Electrical, Benha Faculty of Engineering, Benha University, Tukah, Egypt*

**Key words:** HVDC circuit breaker, Cassie breaker, modifications, arc, capability

### Corresponding Author:

Mahmoud Ahmed Saad

*Department of Power and Electrical, Benha Faculty of Engineering, Benha University, Tukah, Egypt*

Page No.: 51-59

Volume: 14, Issue 5, 2020

ISSN: 1990-7958

International Journal of Electrical and Power Engineering

Copy Right: Medwell Publications

**Abstract:** Arc interruption of High Voltage Direct Current (HVDC) Circuit Breakers (CBs) is one of the main challenging factors for using HVDC grids. To evaluate the arc interrupting capability in HVDC circuit breakers, black box arc models are used to represent the non-linear arc conductance depending on Cassie and Mayr dynamic arc equations. A real line represents a part of 500 kV electrical connection systems between Egypt and Kingdom Saudi Arabia is simulated to be a faulty load. Cassie breaker in normal operation doesn't need commutation circuit but in this study, we will investigate the influence of using commutation circuit with Cassie breaker. It is founded that the commutation circuit doesn't generate resonance but for changing the total impedance of circuit breaker and this leads to decrease both of the arcing voltage and arcing time. Moreover, we will study the effect of using multi-break of Cassie breaker type when using commutation circuit.

## INTRODUCTION

In September 2020, High Voltage Direct Current (HVDC) Circuit Breakers (CBs) play a vital role in the growth of HVDC power systems which can widely help in replacing fossil fuels with renewable energy sources<sup>[1-8]</sup>. The main usage of HVDC system is to connect two AC networks with different frequencies and to transmit large amounts of power via. long distances<sup>[9-16]</sup>.

The key challenge that faces the expansion of HVDC CBs is the absence of natural current zero crossing. As a matter of fact in AC interrupting processes the current decrease to zero naturally. On the other hand in DC interrupting processes the current needs to be forced to zero. Therefore, to form a HVDC CB, it is necessary to install additional components on conventional AC circuit breaker to form artificial current zero crossing<sup>[16-19]</sup>. A lot of works have been directed to create artificial zero crossing in the DC current by using active and passive commutation types<sup>[16, 91-21]</sup>.

Arc is considered the main aspect of the interruption process. Many electric arc models are developed for describing arc behavior<sup>[16, 21-24]</sup>. Conventional arc models are classified into physical arc models and black box arc models. The physical arc model describes the entire arc behavior during the interruption. Therefore, it can be used to investigate the arc behavior in details but it is very complicated to be applied. Otherwise, the black box arc model can be considered the proper method to describe the arc behavior<sup>[21, 25-28]</sup>. Black box models represent the non-linear arc conductance variation with time<sup>[16, 21, 25]</sup>. The choice of black box model equations to determine their parameters is essential, hence, it requires making certain assumptions about the arc behavior<sup>[16, 17, 21]</sup>.

As the main purpose of the black box arc model is to describe the interaction between the arc and the electrical circuit during the current interruption process, Cassie and Mayr dynamic arc equations can be considered the most representative arc models<sup>[16-17, 19]</sup>.

For applying Mayr's model to interrupt DC current an resonance (LC) circuit is coupled in parallel with the circuit breaker to generate self-excited oscillatory current super imposed on the DC current forming zero current crossing<sup>[16, 17, 22-35]</sup>. However, when applying Cassie's Model, there is no need to use a parallel resonance circuit with the breaker, it is only required to make the steady state arc voltage over supply voltage to decrease the current quickly to zero<sup>[16, 21]</sup>. Besides, a circuit element is used to control the rate of rise of recovery voltage (RRRV) and an absorber element to absorb the energy stored in the system inductance after arc interruption. These two circuit elements are used with the arc simulation by both Mayr and Cassie models<sup>[16, 19, 33]</sup>. This study introduces some modifications on Cassie breaker such as reducing the arcing time and voltage to increase its efficiency and lifetime and its usage.

DC fault test bed modeling is carried out by MATLAB/Simulink software to evaluate the capability to protect the HVDC over head transmission line, connecting Badr substation in Egypt and Elnabaq switching station. Such line represents a part of 500 kV electrical connection systems between Egypt and Kingdom Saudi Arabia.

## MATERIALS AND METHODS

**Modeling of HVDC circuit breaker:** Figure 1 shows the puffer type of SF6 gas CB structure including the simulated arc, rated voltage of 525 kV, lightning impulse withstand voltage of 1175 kV, rated normal current of 2000 A, rated short time current (1 sec) of 40 kA, rated peak withstand current of 100 kA and rated short circuit making current of 100 kA.

As it is known, the HVDC arc can be considered as a nonlinear phenomenon which occurs due to two factors. The first one is the high short circuit current that generates heat leading to the circuit breaker contacts and quenching medium temperatures increase, consequently, a sufficient quantity of electrons are emitted. In addition, at the arc initiation when the value of the voltage between the two contacts exceeds the ionization voltage of the inter-electrode gas, the gas may be sufficiently ionized.

SF6 gas has electronegativity characteristics which means that the SF6 gas takes the free electrons far away from the field as a result of this action; the SF6 gas becomes electrically unstable and leaves the electrons quickly. Consequently, the electrons move in a random motion, where the only way to reignite the arc is to achieve an oriented motion of the free electrons.

Black box models are applied using the models of Mayr and Cassie. Mayr's equation can be deduced from the energy balance equation as given in (Eq. 1):

$$dQ/dt = P(H) - P(Q) \quad (1)$$

Where:

P(H) = The heat generated with the assumption that the cooling power

P(Q) = The arc conductance

g(Q) = Arbitrary functions of Q

The general form of the dynamic arc equation of current *i* is represented as follows:

$$dg/dt = (1/[dQ/dg]) * (i^2/g-p) \quad (2)$$

By further assumption of  $Q = Q_0 \ln(g/G_0)$  where  $Q_0$  and  $G_0$  are constants describing the arc, the thermal time constant is defined by  $\tau = Q_0/p$ . Thus, Mayr dynamic arc equation can be presented as given in (Eq. 3):

$$(p * \tau / g) * dg/dt = i^2/g - p \quad (3)$$

It is worth mentioning that by eliminating the hypothesis has the time constant  $\tau$  and cooling power are constants, it leads to a generalized form of Mayr's equation as given below in Eq. 4, where  $\mu$  is the arc voltage:

$$(1/g) * dg/dt = 1/\tau * (g\mu^2/p - 1) \quad (4)$$

Meanwhile, Cassie defines the arc behavior with the following hypothesis and assumptions the arc column has

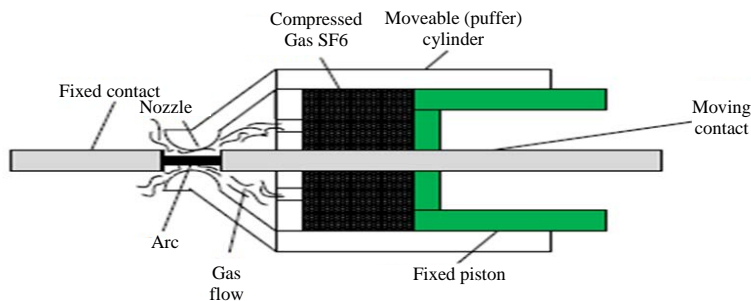

Fig. 1: The puffer type of SF6 circuit breaker structure

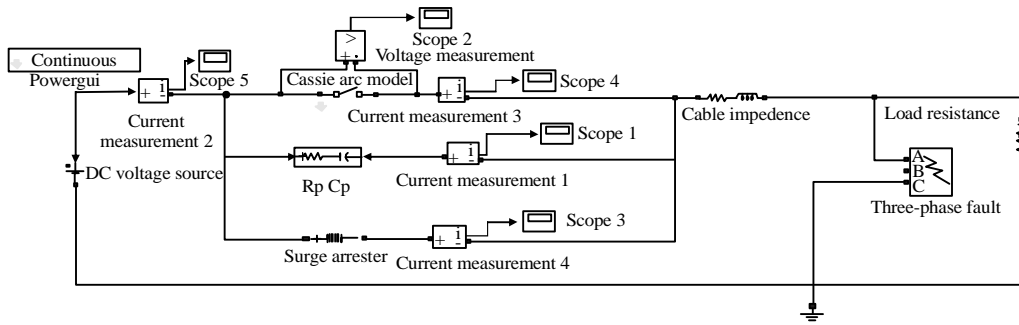

Fig. 2: The main circuit breaker of Cassie model

a cylindrical shape filled with highly ionized gas and free electrons, arc cylindrical column has uniform temperature and current density but its diameter is altered in time and accommodate the change in current, arc voltage is considered constant during the arc process and finally, the power dissipation is considered proportional to the column cross sectional area. With these assumptions, a linear relation between arc conductance and energy storage capacity of the arc is presented by the following (Eq. 5) which represents the last form of Cassie's equation (Fig. 2).

$$(1/g) * dg/dt = 1/\tau * (u^2/Uc^2 - 1) \quad (5)$$

Where:

- $\tau$  = The arc time constant
- $p$  = The arc power loss coefficient
- $g$  = The arc conductance (i/u)
- $u$  = The arc voltage
- $Uc$  = The steady state arc voltage

After simulating the non-linear arc conductance using black box arc models, it should be noted that there is a need to use additional circuit elements that connected with HVDC CB to interrupt the electrical arc<sup>[16]</sup> (Fig. 2).

### RESULTS AND DISCUSSION

Figure 2-4 show the results of applying Cassie model test bed 15 where the rated current and line to line fault circumstances are 750 A and 20 KA, respectively.

It is also observed that when the DC current reaches to 20 kA, the fault is detected and the DC circuit breaker contacts started to open at 0.01 sec as shown in Fig. 2 and 3. It is also noticed that from (Fig. 1-13) at the point of 0.0188 sec, the HVDC CB completely interrupts the arc current and extinguishes the arc and this means that the circuit breaker needs >3.8 m sec to interrupt the fault current. As the max peak of voltage value across CB in this system is 700 kV as shown in Fig. 2.

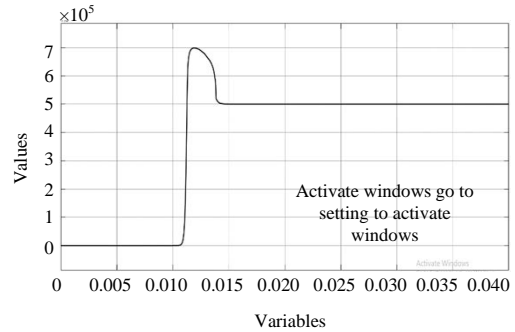

Fig. 3: The voltage across the circuit breaker

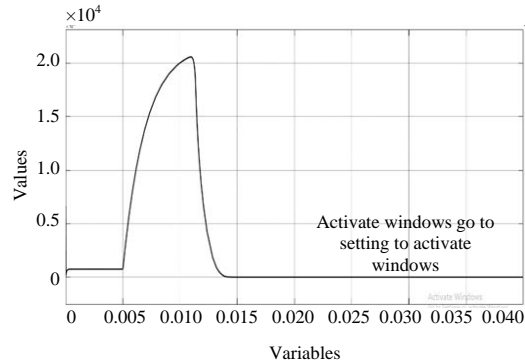

Fig. 4: The current through the circuit breaker

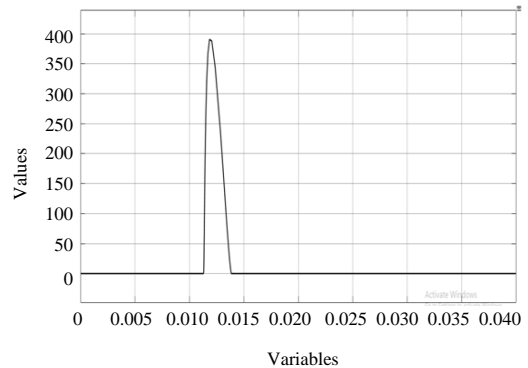

Fig. 5: The current through surge arrester

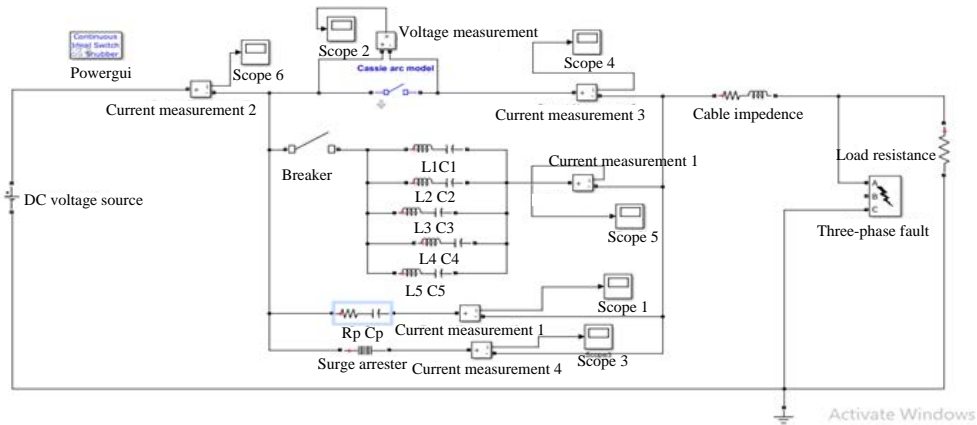

Fig. 6: The main model of circuit breaker with communication circuit

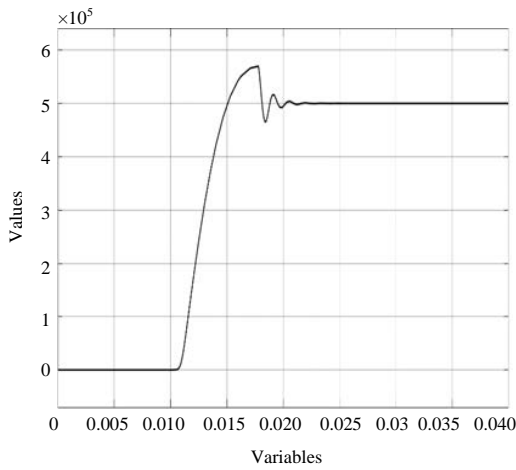

Fig. 7: The voltage across the circuit breaker

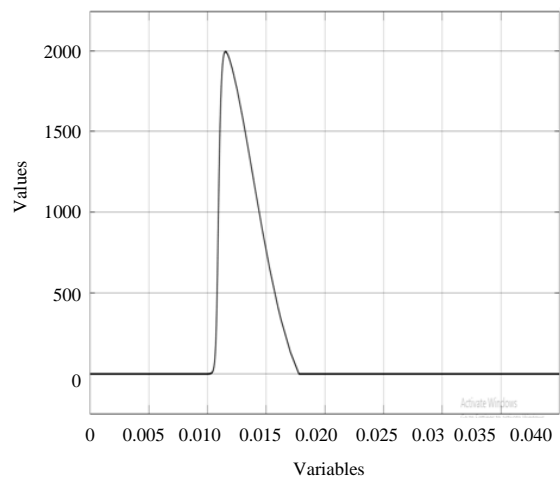

Fig. 9: The current through the communication circuit

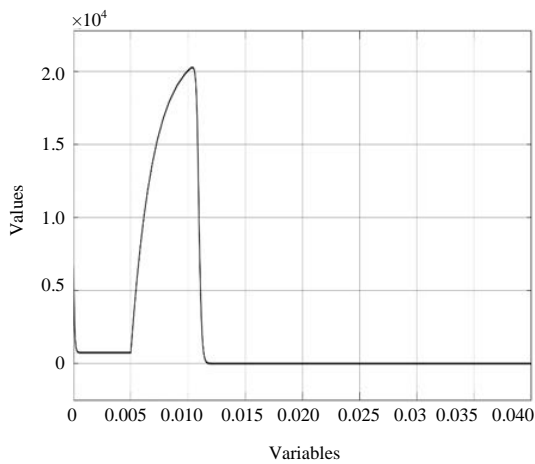

Fig. 8: The current through the circuit breaker

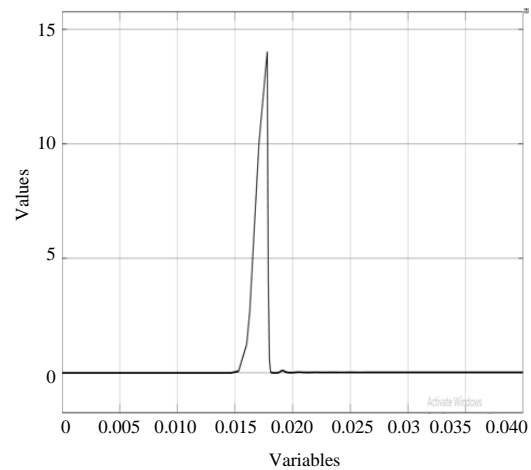

Fig. 10: The current through the surge arrester

The test shows that for Cassie model the value of the steady state arc voltage should be over than the supply voltage to decrease the value of fault current to reach zero

quickly, otherwise the breaker cannot effectively interrupt the fault current. It is noticed that, during the interval time

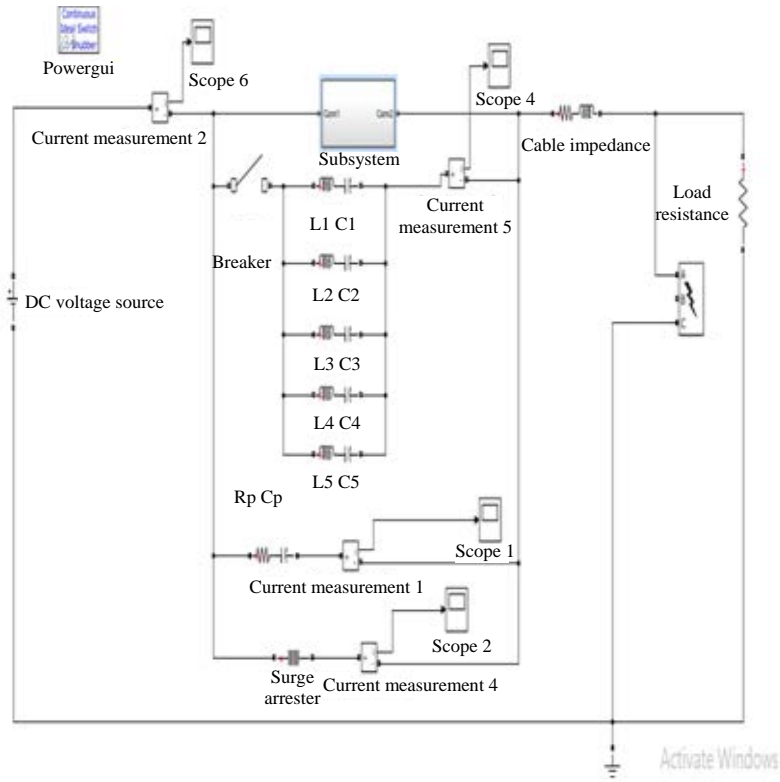

Fig. 11: The main model of multi break circuit breaker

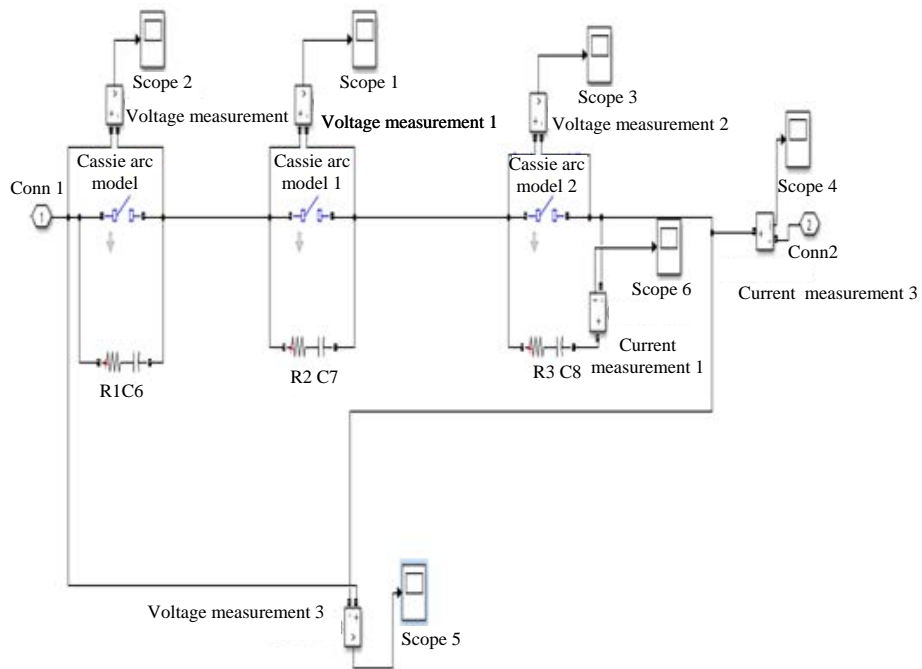

Fig. 12: The subsystem of multi break circuit breaker

near current zero crossing, not only the arc current is decreased but also the arc voltage is decreased as

shown in Fig. 2. It is noticed that the current through surge arrester is 3900 A as shown in Fig. 2-4.

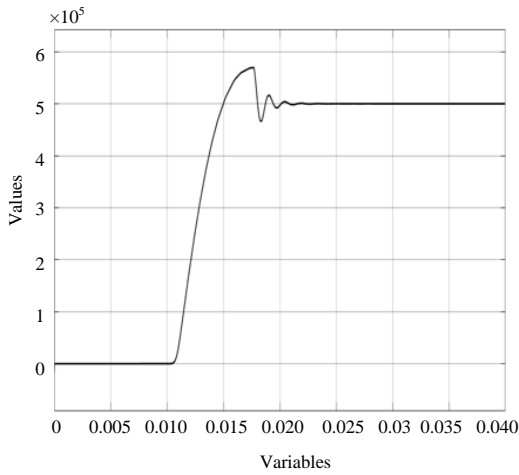

Fig. 13: The total average across the circuit breaker

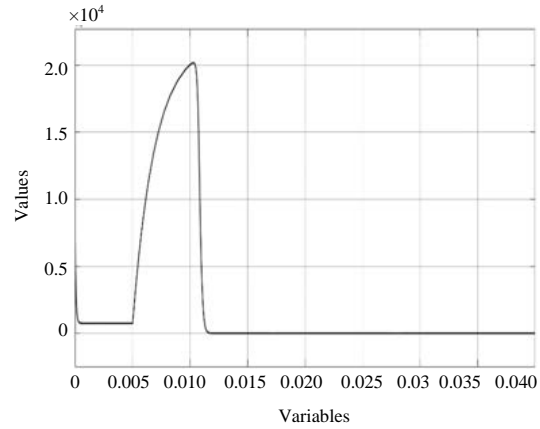

Fig. 15: The current through the circuit breaker

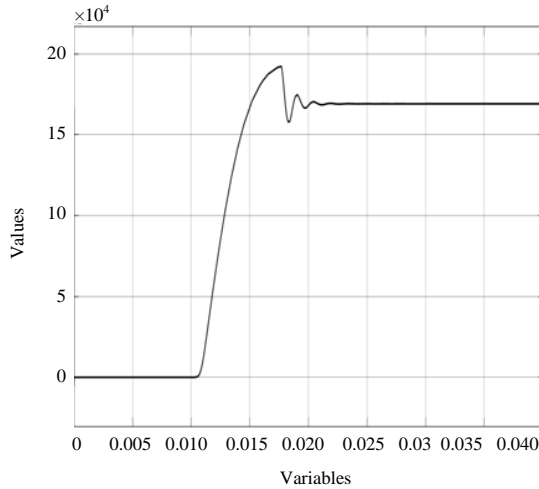

Fig. 14: The voltage across each pole of the circuit breaker

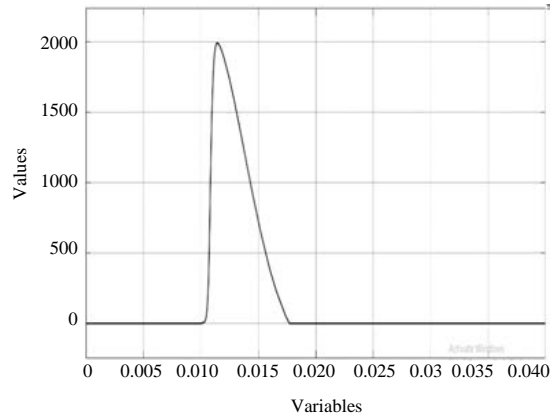

Fig. 16: The current through the commutation circuit

Table 1: Simulation parameters of the model of Cassie

Models	Parameters	Default values
Normal circuit breaker	$U_c$ (KV)	750
	$\tau$ ( $\mu$ sec)	100
	$R_p$ ( $\Omega$ )	75
	$C_p$ ( $\mu$ F)	0.001

Actually, as the principle of Cassie arc model depends on the convection loss in the region of high current, so that, the Cassie arc model is not fit near current zero crossing (Table 1).

Figure 2-9 show the results of applying Cassie model test bed after adding Commutation circuit not for making resonance to get zero crossing but for changing the circuit breaker impedance to reduce both of arcing time and voltage as it shown in Fig. 2-7 where the rated current and line to line fault circumstances are 750 A and 20 KA, respectively. It is also observed that

when the DC current reaches to 20 kA, the fault is detected and the DC circuit breaker contacts started to open at 0.01 sec as shown in Fig. 2-7 (Table 2 and 3).

It is also noticed that from Fig. 2-7 at the point of 0.0118 sec, the HVDC CB completely interrupts the arc current and extinguishes the arc and this means that the circuit breaker needs 6.8 m sec to interrupt the fault current. As the max peak of voltage value across CB in this system is 570 kV as shown in Fig. 2-6. It is also noticed from Fig. 2-9 that the current through surge arrester is 15 A.

Figure 2-10 show the results of applying three series poles circuit breaker of Cassie Model test bed after adding commutation circuit not for making resonance to get zero crossing but for changing the circuit breaker impedance to reduce both of arcing time and voltage as it shown in Fig. 1-17 and where the rated current and line to line fault circumstances are 750 A and 20 KA, respectively. It is also observed that



Table 2: Simulation parameters of the model of Cassie after adding commutation circuit

Models	Parameters	Default values
Circuit breaker after adding commutation circuit	$U_c$ (KV)	750
	$\zeta$ ( $\mu$ sec)	322
	$R_p$ ( $\Omega$ )	75
	$C_p$ ( $\mu$ F)	1
	L1, L2, L3, L4, L5 (mH)	0.25
	C1, C2, C3, C4, C5 ( $\mu$ F)	25

Table 3: Simulation parameters of Cassie after using multi-break and commutation circuit

Models	Parameters	Default values
Circuit breaker after using multi-break and commutation circuit	$U_c$ (KV)	750
	$\zeta$ ( $\mu$ sec)	100
	$R_p$ ( $\Omega$ )	75
	R1, R2, R3( $\Omega$ )	0.15
	$C_p$ ( $\mu$ F)	1
	C6,C7,C8 (pF)	100
	L1, L2, L3, L4, L5 (mH)	0.25
	C1, C2, C3, C4, C5 ( $\mu$ F)	25

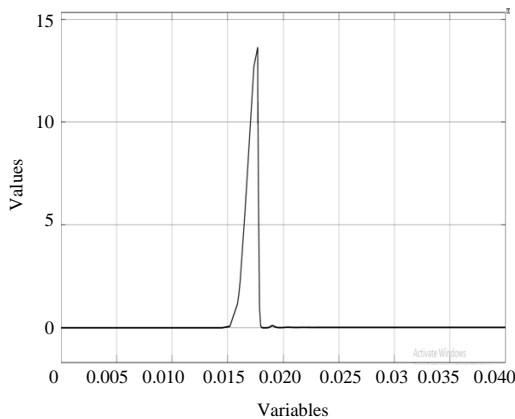

Fig. 17: The current through surge arrester

when the DC current reaches to 20 kA, the fault is detected and the DC circuit breaker contacts started to open at 0.01 sec as shown in Fig. 1-17.

It is also noticed that from Fig. 1-17 at the point of 0.012 sec, the HVDC CB completely interrupts the arc current and extinguishes the arc and this means that the circuit breaker needs 7 m sec to interrupt the fault current. As the max peak of voltage value across CB in this system is 570 kV as shown in Fig. 1-17. The voltage at each pole reaches 190 KV then saturates at 167 kV as it is shown in Fig. 1-17.

### CONCLUSION

In this study, black box arc model is used to represent the non-linear arc conductance depending on Cassie Model. Cassie's Model isn't used in as much as Mayr, so we will make some modifications to increase its efficiency and usage. It is found that the arcing time is reduced by increasing the number of parallel branches of commutation circuit, decreasing the arcing time constant.

It is also concluded that using multi-break circuit breaker is better than using number of cascaded series circuit breakers.

### REFERENCES

01. Franck, C.M., 2011. HVDC circuit breakers: A review identifying future research needs. IEEE. Trans. Power Delivery, 26: 998-1007.
02. Meah, K. and S. Ula, 2007. Comparative evaluation of HVDC and HVAC transmission systems. Proceedings of the 2007 IEEE Power Engineering Society General Meeting, June 24-28, 2007, IEEE, Tampa, Florida, pp: 1-5.
03. Mobarrez, M., M.G. Kashani, S. Bhattacharya and R. Adapa, 2014. Comparative study of DC circuit breakers using realtime simulations. Proceedings of the IECON 2014-40th Annual Conference of the IEEE Industrial Electronics Society, October 29-November 1, 2014, IEEE, Dallas, Texas, pp: 3736-3742.
04. Lu, W. and B.T. Ooi, 2003. Optimal acquisition and aggregation of offshore wind power by multiterminal voltage-source HVDC. IEEE. Trans. Power Delivery, 18: 201-206.
05. Meyer, C., M. Hoing, A. Peterson and D.R.W. Doncker, 2007. Control and design of DC grids for offshore wind farms. IEEE. Trans. Ind. Appl., 43: 1475-1482.
06. Anonymous, 2006. Trans-mediterranean interconnection for concentrating solar power. DLR, German Aerospace Center, Institute of Technical Thermodynamics, Section Systems Analysis and Technology Assessment, Germany.
07. Billon, V.C., J.P. Taisne, V. Arcidiacono and F. Mazzoldi, 1989. The Corsican tapping: From design to commissioning tests of the third terminal of the Sardinia-Corsica-Italy HVDC. IEEE. Trans. Power Delivery, 4: 794-799.
08. Kirby, N., L. Xu, M. Lockett and W. Siepmann, 2002. HVDC transmission for large offshore wind farms. Power Eng. J., 16: 135-141.
09. McCallum, D., G. Moreau, J. Primeau, M. Bahrman, B. Ekehov and D. Soulier, 1994. Multi-terminal integration of the Nicolet converter station in to the Quebec-New England phase II HVDC transmission system. Proceedings of the CIGRE 35th International Conference on Large High Voltage Electric Systems, September 1994, Paris, France, pp: 1-9.
10. Greenwood, A., K. Kanngiessner, V. Lesclae, T. Margaard and W. Schultz, 1996. Circuit breakers for meshed multi-terminal HVDC systems. Part II: Switching of transmission lines in meshed MTDC systems. Electra, 164: 62-82.

11. Li, Y., Z. Zhang, C. Rehtanz, L. Luo, S. Ruberg and F. Liu, 2010. Study on steady-and transient-state characteristics of a new HVDC transmission system based on an inductive filtering method. *IEEE. Trans. Power Electron.*, 26: 1976-1986.
12. Guo, C., W. Liu and C. Zhao, 2013. Research on the control method for voltage-current source hybrid-HVDC system. *Sci. China Technol. Sci.*, 56: 2771-2777.
13. Zhang, X., J. Bai, G. Cao and C. Chen, 2013. Optimizing HVDC control parameters in multi-infeed HVDC system based on electromagnetic transient analysis. *Int. J. Electr. Power Energy Syst.*, 49: 449-454.
14. Chang, B., O. Cwikowski, M. Barnes and R. Shuttleworth, 2015. Multi-terminal VSC-HVDC pole-to-pole fault analysis and fault recovery study. *Proceedings of the 11th IET International Conference on AC and DC Power Transmission*, February 10-12, 2015, Birmingham, UK., pp: 1-8.
15. Mohammadi, M., M. Avendano-Mora, M. Barnes and J.Y. Chan, 2013. A study on fault ride-through of VSC-connected offshore wind farms. *Proceedings of the 2013 IEEE Power & Energy Society General Meeting*, July 21-25, 2013, IEEE, Vancouver, Canada, pp: 1-5.
16. Gouda, O.E., D.K. Ibrahim and A. Soliman, 2018. Parameters affecting the arcing time of HVDC circuit breakers using black box arc model. *IET. Gener. Transm. Distrib.*, 13: 461-467.
17. Xiang, B., L. Zhang, K. Yang, Y. Tan and Z. Liu *et al.*, 2016. Arcing time of a DC circuit breaker based on a superconducting current-limiting technology. *IEEE. Trans. Applied Supercond.*, 26: 1-5.
18. May, T.W., Y.M. Yeap and A. Ukil, 2016. Comparative evaluation of power loss in HVAC and HVDC transmission systems. *Proceedings of the 2016 IEEE Region 10 Conference (TENCON)*, November 22-25, 2016, IEEE, Singapore, pp: 637-641.
19. Darwish, H.A., M.A. Izzularab and N.I. Elkalashy, 2006. Enhanced commutation circuit design of HVDC circuit breaker using EMTP. *Proceedings of the 2005/2006 IEEE/PES Transmission and Distribution Conference and Exhibition*, May 21-24, 2006, IEEE, Dallas, Texas, pp: 978-985.
20. Qin, T., E. Dong, G. Liu and J. Zou, 2016. Recovery of dielectric strength after DC interruption in vacuum. *IEEE. Trans. Dielectr. Electr. Insul.*, 23: 29-34.
21. Lim, S.W., U.A. Khan, J.G. Lee, B.W. Lee, K.S. Kim and C.W. Gu, 2015. Simulation analysis of DC arc in circuit breaker applying with conventional black box arc model. *Proceedings of the 2015 3rd International Conference on Electric Power Equipment-Switching Technology (ICEPE-ST)*, October 25-28, 2015, IEEE, Busan, South Korea, pp: 332-336.
22. Nakao, H., Y. Nakagoshi, M. Hatano, T. Koshizuka and S. Nishiwaki *et al.*, 2001. Dc current interruption in HVDC SF6 gas MRTB by means of self-excitation. *IEEE. Power Eng. Rev.*, 21: 62-62.
23. Smeets, R.P.P. and V. Kertesz, 2013. Application of a validated AC black-box arc model to DC current interruption. *Proceedings of the 2013 2nd International Conference on Electric Power Equipment-Switching Technology (ICEPE-ST)*, October 20-23, 2013, IEEE, Matsue, Japan, pp: 1-4.
24. Zhu, K., X. Li, S. Jia, W. Zhang and W. Gao, 2015. Study of the switching arc characteristics of a 500 kV HVDC self-excited oscillatory metallic return transfer breaker. *IEEE. Trans. Dielectr. Electr. Insul.*, 22: 128-134.
25. Walter, M. and C. Franck, 2014. Improved method for direct black-box arc parameter determination and model validation. *IEEE. Trans. Power Delivery*, 29: 580-588.
26. Pauli, B., G. Mauthe, E. Ruoss and G. Ecklin, 1988. Development of a high current HVDC circuit breaker with fast fault clearing capability. *IEEE. Trans. Power Delivery*, 3: 2072-2080.
27. Greenwood, A., K. Kanngiessner, V. Lesclae, T. Margaard and W. Schultz, 1995. Circuit breakers for meshed multi-terminal HVDC systems part I: Introduction DC side substation switching under normal and fault conditions. *Electra*, 163: 98-122.
28. Garzon, R.D., 2002. *High Voltage Circuit Breakers High Voltage Circuit Breakers: Design and Applications*. 2nd Edn., Marcel Dekker Publishing, New York, USA.,.
29. De Andrade, V. and E. Sorrentino, 2010. Typical expected values of the fault resistance in power systems. *Proceedings of the 2010 IEEE/PES Transmission and Distribution Conference and Exposition: Latin America (T&D-LA)*, November 8-10, 2010, IEEE, Sao Paulo, Brazil, pp: 602-609.
30. Ohtaka, T., V. Kertesz and R.P.P. Smeets, 2017. Novel black-box arc model validated by high-voltage circuit breaker testing. *IEEE. Trans. Power Delivery*, 33: 1835-1844.



31. Esenwein, F.D. and R.G. Colclaser, 1995. Simulation of arc-circuit instability in a low current DC automotive switching application. IEEE. Trans. Veh. Technol., 44: 348-355.
32. Pugliese, H. and M. Vonkannewurff, 2010. Direct current circuit breaker primer. Proceedings of the 2010 Record of Conference Papers Industry Applications Society 57th Annual Petroleum and Chemical Industry Conference (PCIC), September 20-22, 2010, IEEE, San Antonio, Texas, pp: 1-7.
33. Lee, J.G., U.A. Khan, H.Y. Lee and B.W. Lee, 2016. Impact of SFCL on the four types of HVDC circuit breakers by simulation. IEEE. Trans. Applied Supercond., 26: 1-6.
34. Bizzarri, F., A. Brambilla, G. Gruosso, G.S. Gajani, M. Bonaconsa and F. Viaro, 2017. A new black-box model of SF 6 breaker for medium voltage applications. Proceedings of the IECON 2017-43rd Annual Conference on IEEE Industrial Electronics Society, October 29-November 1, 2017, IEEE, Beijing, China, pp: 32-37.
35. Park, K.H., H.Y. Lee, M. Asif, B.W. Lee, T.Y. Shin and C.W. Gu, 2017. Assessment of various kinds of AC black-box arc models for DC circuit breaker. Proceedings of the 2017 4th International Conference on Electric Power Equipment-Switching Technology (ICEPE-ST), October 22-25, 2017, IEEE, Xi'an, China, pp: 465-469.