

## Power Quality Enhancement Through Active Filtering Schemes for Fluctuating Industrial Loads

S. Elangovan and K. Thanushkodi  
Department of EEE, Akshaya College of Engineering and Technology,  
642 109 Coimbatore, India

**Abstract:** To improve the quality of the electrical power to the consumers, many power electronic based solutions are available. In the case of active power factor compensation, grid connected voltage source inverter based Shunt Active Power Filter is the versatile solution. But in this system most of the control strategies demand generation of unit vector based on the grid voltage for vector orientation. Due to presence of harmonics in grid voltages and the level of noise in the grid voltage sensing circuits will make estimation of unit vector to be difficult and PLL circuits are necessary. This study presents a simple and efficient method to evaluate the unit vector without the use of PLL or any hardware filter network. This method utilizes d-q reference frame control strategy for shunt active filter and is simulated with a 100 kVAR System. The proposed active filter network is simulated in MATLAB/SIMULINK and the simulation results are presented to validate the effectiveness of this control strategy.

**Key words:** Active filtering function, direct power control, power quality enhancement, space vector modulation, shunt active power filter, vector control

### INTRODUCTION

Process industries use wide range of variable speed motor drives, ac plants, UPS systems and various power electronic converters to improve system efficiency and hence the productivity. These loads draw reactive power from the grid. Excess reactive power will result in poor voltage regulation and poor utilization of ac network, mainly the distribution transformer for the plant. These constraints make it necessary to compensate reactive power. Traditionally, passive elements like ac capacitor banks are used for reactive power compensation. But the effectiveness of these capacitors is limited. Moreover, they have some disadvantages like drawing fixed amount of leading reactive power irrespective of the load requirements. For continuously varying load which is the case in most of the process industries these fixed capacitor banks fail to control the power factor effectively.

Thyristor switched or mechanically switched capacitor banks are also used to improve this situation. But they too cannot maintain the power factor near unity when the load varies rapidly. Also, the life span of these passive elements is less due to load harmonics, current sinking and these results in regular maintenance. Due to these limitations of passive filters, various active filters have been reported for reactive power compensation

(Peng, 1998; Bhattacharya and Divan, 1996; Ghosh and Joshi, 2002; Rodriguez *et al.*, 2002; Liu *et al.*, 2012). In this study, synchronous d-q reference frame based control strategy is presented for a 100 kVAR two-level shunt active filter. The control law is derived for the compensation of reactive power drawn from grid. This study also presents a simple and efficient method of unit vector generation which will minimize the effect of harmonics and noise present in the grid voltage feedback.

### SHUNT ACTIVE POWER FILTER

The basic block diagram of a three phase shunt active filter is shown in Fig. 1. This STATCOM is

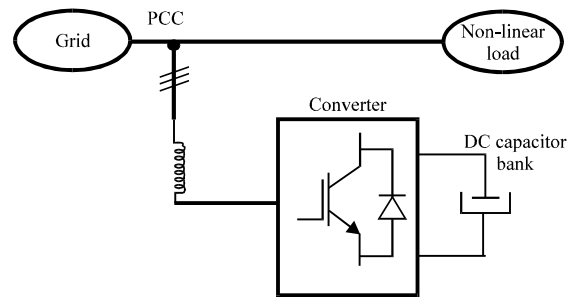

Fig. 1: Grid tied VSI based shunt active power filter

primarily a voltage source inverter connected to point of control, several control strategies such as instantaneous reactive power based hysteresis current controller (Akagi *et al.*, 1984, 1986; Akagi, 1996), sliding mode controller (Saetieo *et al.*, 1997; Gous and Beukes, 2004), synchronous reference frame controller (Sensarma *et al.*, 2000), etc. have been proposed and developed for a three phase voltage source inverter based shunt compensator. A novel method is of control technique is proposed by Chandra *et al.* (2000), comparison analysis is done by Labben-Ben Braiek *et al.* (2002). A reference compensation current strategy is introduced by Chang and Shee (2004). Most of these control strategies require computations using the grid voltage sensed at PCC. Many other techniques of Control algorithms of shunt active power filter is proposed by Rahmani *et al.* (2014, 2013), Luo *et al.* (2009), Corasaniti *et al.* (2013), Karanki *et al.* (2013), Peng (1998), Abrahamsen and David (1995), Malinowski *et al.* (2001, 2003) and Ghosh and Joshi (2002).

But the source harmonics and the noise in the feedback circuit for grid voltage restrict direct use of the voltage signals in the Control algorithm. The harmonics present in the grid voltage can be filtered using hardware band-pass filter (Sensarma *et al.*, 2000). But it is very difficult to design such a filter with precise choice of cut-off frequency that would separate out the fundamental without appreciable phase errors. Some research has been reported on the use of PLL (Bhattacharya and Divan, 1996; Oliver *et al.*, 2002; Kazmierkowski *et al.*, 2002; Rodriguez *et al.*, 2002; Cichowlas *et al.*, 2011; Chung, 2000) to remove the effect of harmonics and noise in the grid voltage. But the design of a high performance PLL is not so easy when various non-idealities like multiple zero crossing in the grid voltage are occurring.

### PROPOSED SCHEME

As mentioned earlier, the three phase shunt active filter is a fully controlled three phase boost converter which is connected to the grid through a three-phase series choke. This converter supplies the required reactive power to the load to maintain the grid side power factor unity. The series choke separates the two voltage sources namely grid and inverter. The capacitor voltage is maintained at a constant value by closed loop control which regulates the active power drawn from the grid and caters to the internal losses of the system.

Synchronous d-q reference frame based control strategy is proposed to control this converter. This control strategy requires sensing of grid voltage and generation of unit vectors for the orientation along the

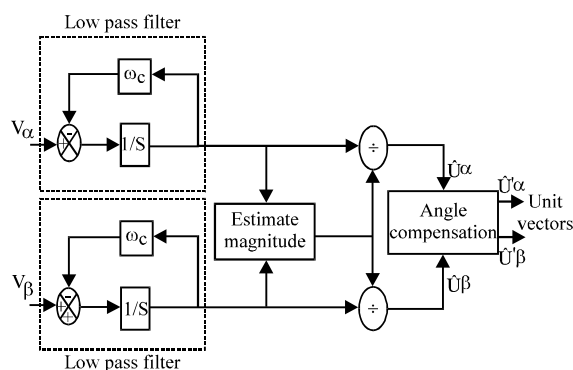

Fig. 2: Block diagram of unit vector generation

grid voltages. Figure 2 explains the method adopted to reduce the effect of harmonics and noise in the grid voltage feedback.

The sensed grid voltages are filtered using a first order digital low pass filter whose corner frequency is  $\omega_c$ . In the present research,  $\omega_c$  is chosen to be equal to the nominal grid frequency (50 Hz). So, after filtering, the percentage of hth order harmonics of the sensed grid voltage is reduced by a factor of  $\sqrt{\cdot}$  (assuming fundamental voltage is always 100%). It is clear that 5th and higher order harmonics which can normally be present in the line-to-line grid voltage are reduced considerably using this low pass filter. High frequency noise gets eliminated almost completely. Finally, dividing the filter output signals with their magnitude generates the required unit vectors.

However, the grid frequency varies with a small range ( $\pm 2.5$  Hz). So, there is a small phase error in unit vector generation if constant phase compensation is done. Synchronous d-q frame based control strategy is explained using this unit vector.

### CONTROL STRATEGY

The control scheme is presented in Fig. 3. The three phase currents of the load and the converter are transformed into the synchronously rotating reference frame using Eq. 1 and 2. The unit vector required for the transformation is generated with grid voltages as described earlier. In other words, the first step in the control scheme is orienting the converter and grid current:

$$\begin{bmatrix} i_\alpha \\ i_\beta \end{bmatrix} = \begin{bmatrix} 1 & -\frac{1}{2} & -\frac{1}{2} \\ 0 & \frac{\sqrt{3}}{2} & -\frac{\sqrt{3}}{2} \end{bmatrix} \begin{bmatrix} i_a \\ i_b \\ i_c \end{bmatrix} \quad (1)$$

$$\begin{bmatrix} i_d \\ i_q \end{bmatrix} = \begin{bmatrix} \cos \omega t & -\sin \omega t \\ \sin \omega t & \cos \omega t \end{bmatrix} \begin{bmatrix} i_\alpha \\ i_\beta \end{bmatrix} \quad (2)$$

along the grid voltage. The load current will be a composite current containing the fundamental and harmonics. After orientation, the fundamental components of d-axis and q-axis currents are the active and reactive parts, respectively of the fundamental load currents. For grid reactive power compensation, this fundamental q-axis load current is used as the reference of q-axis current controller of the converter. There is a closed loop PI controller to maintain the dc bus constant. The output of this controller generates the reference of d-axis current controller of the converter. The control law (Labben-Ben Braiek *et al.*, 2002; Chang and Shee, 2004) along the d and q axis is given as:

$$V_d = i_d R + L \frac{di_d}{dt} - \omega L i_q + V_g \tag{3}$$

$$V_q = i_q R + L \frac{di_q}{dt} - \omega L i_d \tag{4}$$

Here:

R and L = The resistance and inductance of the series choke

$V_d$  and  $V_q$  = d and q axis voltage commands, respectively

There are two PI current controllers to control the d-axis and q-axis current of the converter. The outputs of these current controllers are added with feed forward

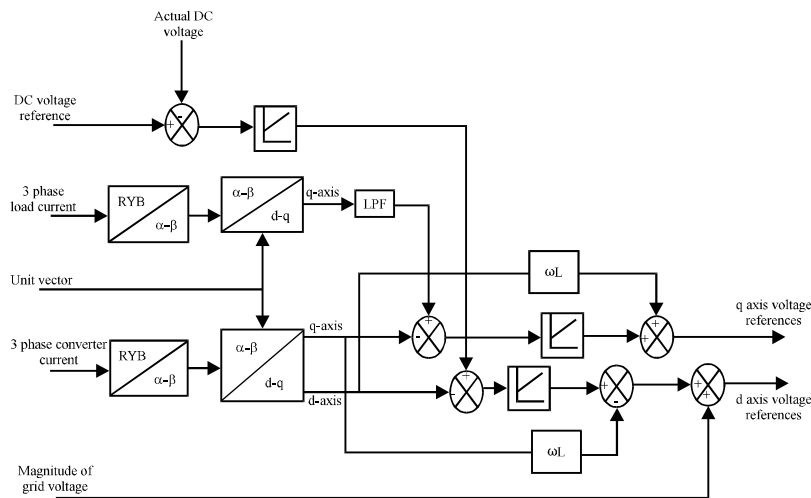

Fig. 3: Control scheme for shunt active power filter

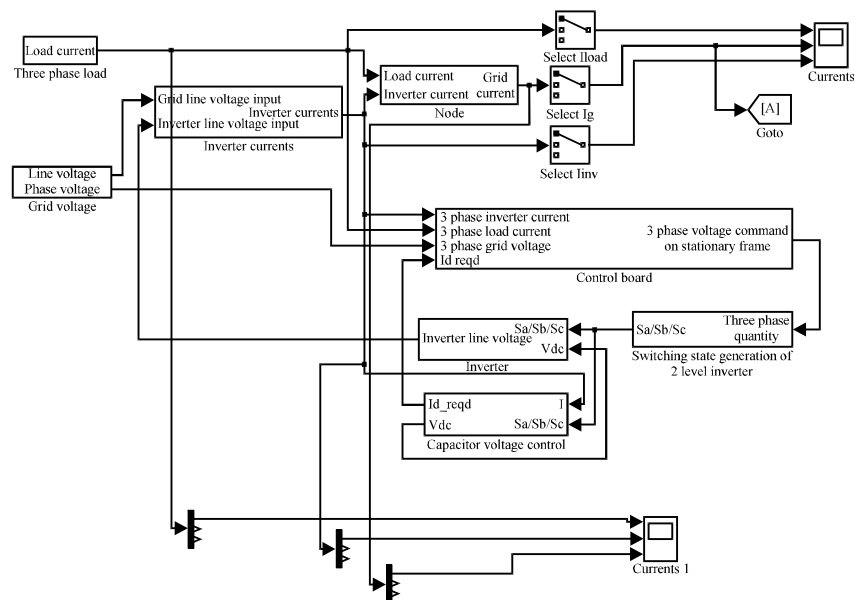

Fig. 4: MATLAB/SIMULINK diagram of the overall system of shunt active power filter

terms based on Eq. 3 and 4 to generate the d-axis and q-axis voltage references for the converter. Finally, d-q voltage references are transformed back to 3-phase stationary voltage references using the unit vectors. These reference signals are fed to the PWM modulator to generate the gate pulses for the converter.

**SIMULATION RESULTS AND ANALYSIS**

The whole system is simulated in MATLAB (Fig. 4 and 5). The three-phase source voltages are

assumed to be balanced and sinusoidal. A load with highly nonlinear characteristics is considered for the load compensation. The simulation result clearly shows that the Control algorithm improves the power factor and the grid current is sinusoidal and so it can be viewed that the harmonics are reduced as shown in the Fig. 6. The simulation results at other two phases namely phase B and C have also shown similar results as in Fig. 7 and 8.

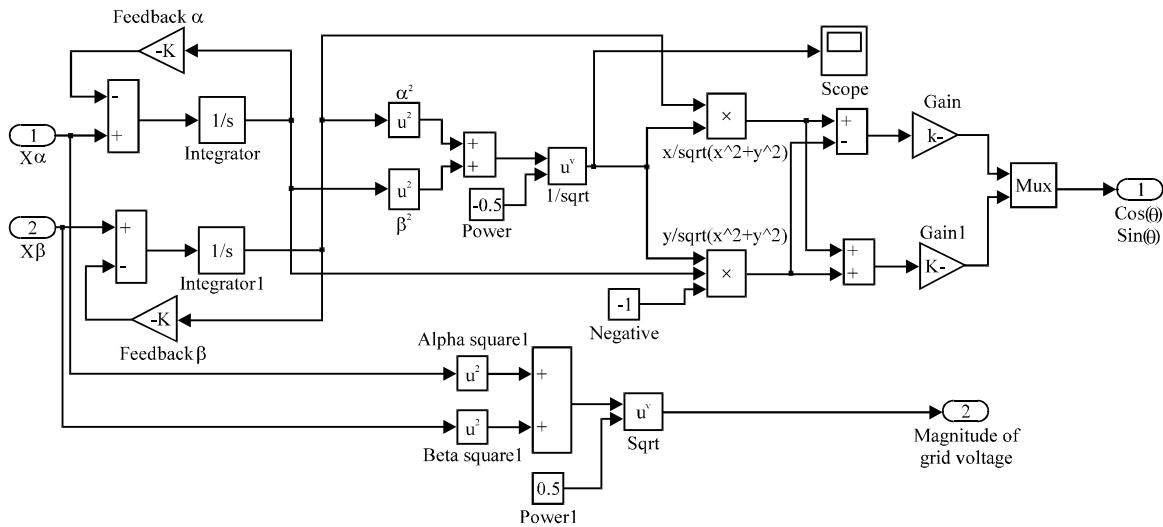

Fig. 5: MATLAB/SIMULINK diagram of unit vector generation

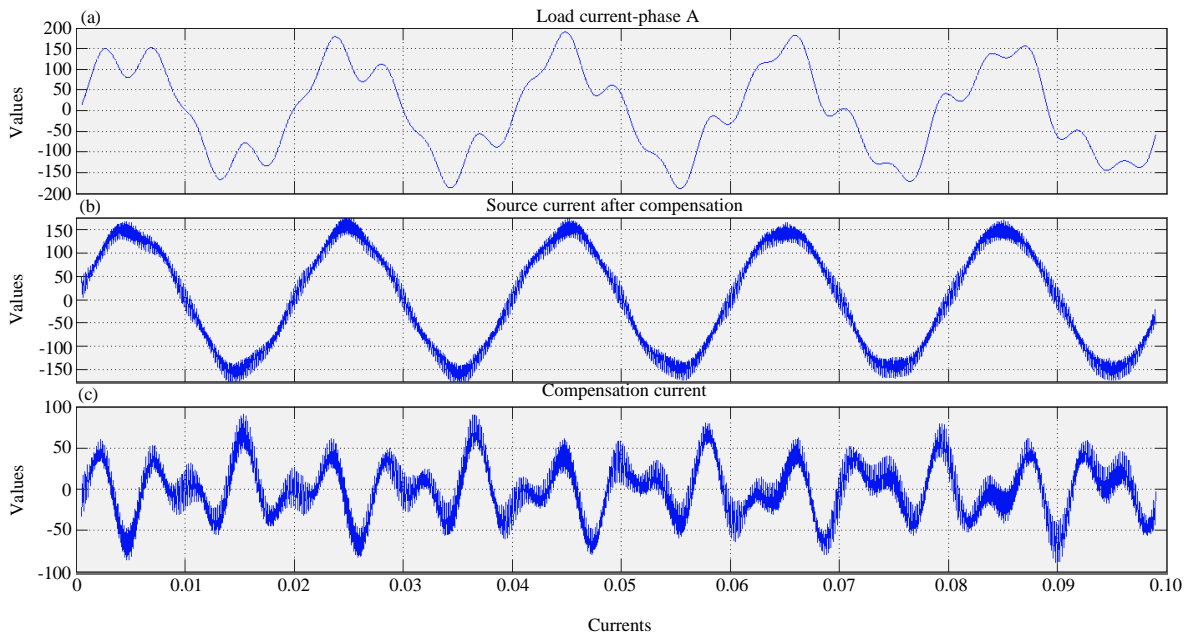

Fig. 6: MATLAB/SIMULINK result of phase A showing the: a) load current for 100 kVAR load; b) source current after compensation and c) compensation current injected by the filter into to the point of common coupling

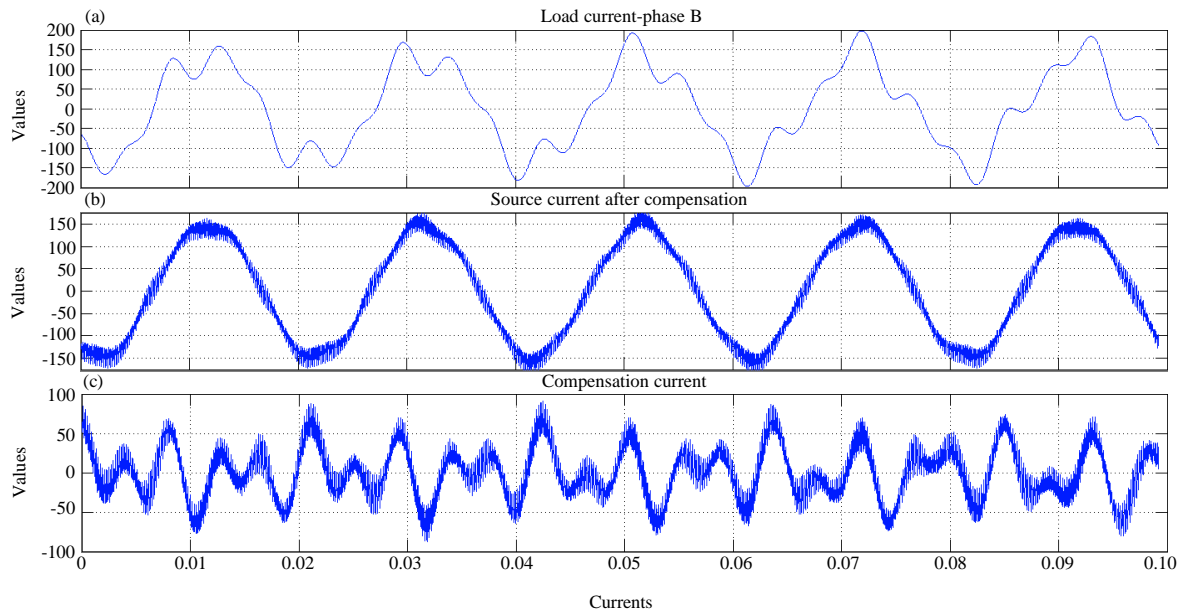

Fig. 7: MATLAB/SIMULINK result of phase B showing the: a) load current for 100 kVAR load; b) source current after compensation and c) compensation current injected by the filter into to the point of common coupling

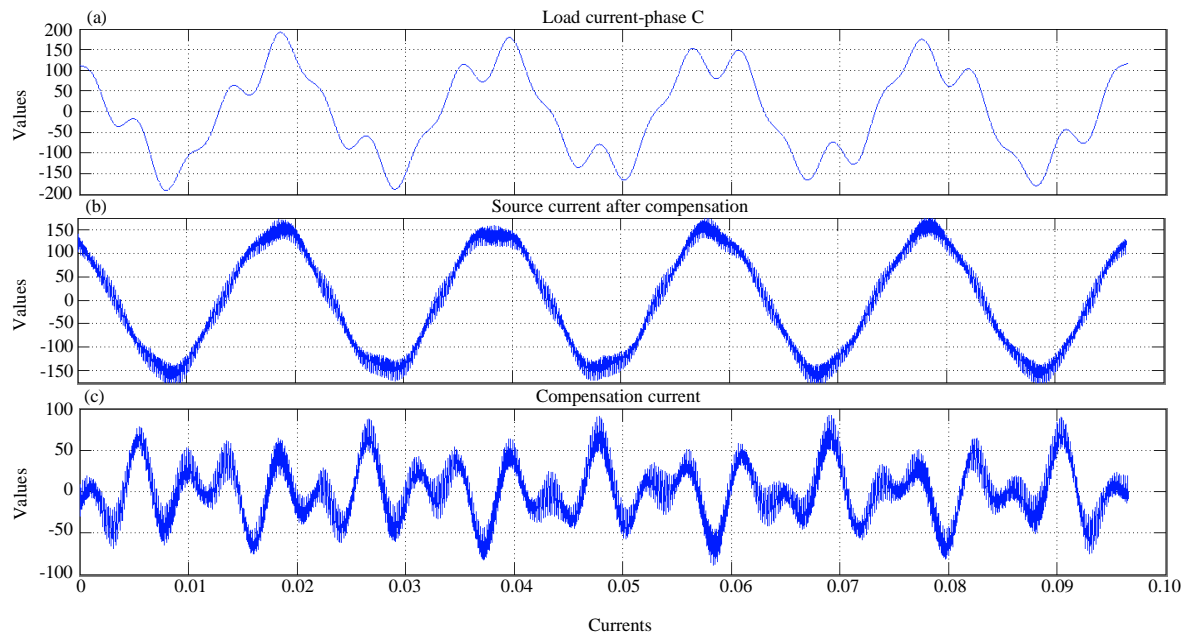

Fig. 8: MATLAB/SIMULINK result of phase C showing the: a) load current for 100 kVAR load; b) source current after compensation and c) compensation current injected by the filter into to the point of common coupling

### CONCLUSION

This study proposed an improved algorithm to generate unit vector from the sensed grid voltage with a reduced effect of harmonics and noise present in the feedback signal. This simplified algorithm was used in synchronous d-q reference frame method for the control of shunt active power filter.

### REFERENCES

Abrahamsen, F. and A. David, 1995. Adjustable speed drive with active filter capability for harmonic current compensations. Proceedings of the 26th Annual IEEE Power Electronics Specialists Conference, Volume 2, June 18-22, 1995, Atlanta, GA., pp: 1137-1143.

- Akagi, H., 1996. New trends in active filters for power conditioning. *IEEE Trans. Ind. Appl.*, 32: 1312-1322.
- Akagi, H., A. Nabae and S. Atoh, 1986. Control strategy of active power filters using multiple voltage source PWM converters. *IEEE Trans. Ind. Appl.*, IA-22: 460-465.
- Akagi, H., Y. Kanazawa and A. Nabae, 1984. Instantaneous reactive compensators comprising switching devices without energy storage components. *IEEE Trans. Ind. Applic.*, IA-20: 625-630.
- Bhattacharya, S. and D. Divan, 1996. Active filter solutions for utility interface of industrial loads. *Proceedings of the International Conference on Power Electronics, Drives and Energy Systems for Industrial Growth, Volume 2, January 8-11, 1996, New Delhi*, pp: 1078-1084.
- Chandra, A., B. Singh, B.N. Singh and K. Al-Haddad, 2000. An improved control algorithm of shunt active filter for voltage regulation, harmonic elimination, power factor correction and balancing of nonlinear loads. *IEEE Trans. Power Electron.*, 15: 495-507.
- Chang, G.W. and T.C. Shee, 2004. A novel reference compensation current strategy for shunt active power filter control. *IEEE Trans. Power Delivery*, 19: 1751-1758.
- Chung, S.K., 2000. A phase tracking system for three phase utility interface inverters. *IEEE Trans. Power Electron.*, 15: 431-438.
- Cichowlas, M., M. Malinowski, M.P. Kazmierkowski and F. Blaabjerg, 2011. Direct power control for three phase PWM rectifier with active filtering function. *Proceedings of the 18th Annual IEEE Applied Power Electronics Conference and Exposition, Volume 2, February 9-13, 2011, Miami beach, FL.*, pp: 913-918.
- Corasaniti, V.F., M.B. Barbieri and P.L. Arnera, 2013. Compensation with hybrid active power filter in an industrial plant. *IEEE Latin Am. Trans.*, 11: 447-452.
- Ghosh, A. and A. Joshi, 2002. A new algorithm for the generation of reference voltages of a DVR using the method of instantaneous symmetrical components. *IEEE Power Eng. Rev.*, 2: 63-65.
- Gous, M.G.F. and H.J. Beukes, 2004. Sliding mode control for a three phase shunt active power filter utilizing a four leg voltage source inverter. *Proceedings of the IEEE 35th Annual Power Electronics Specialists Conference, Volume 6, June 20-25, 2004, Aachen, Germany*, pp: 4609-4619.
- Karanki, K., G. Geddada, M.K. Mishra and B.K. Kumar, 2013. A modified three-phase four-wire UPQC topology with reduced DC-link voltage rating. *IEEE Trans. Ind. Elect.*, 60: 3555-3566.
- Kazmierkowski, M.P., F. Blaabjerg and R. Krishnan, 2002. *Control in Power Electronics: Selected Problems*. Academic Press, USA., Pages: 518.
- Labben-Ben Braiek, M., F. Fnaiech, K. Al-Haddad and L. Yacobi, 2002. Comparison of direct current control techniques for a three phase shunt active power filter. *Proceedings of the IEEE International Symposium on Industrial Electronics, Volume 4, July 8-11, 2002, IEEE.*, pp: 1217-1222.
- Liu, J., P. Zanchetta, M. Degano and E. Lavopa, 2012. Control design and implementation for high performance shunt active filters in aircraft power grids. *IEEE Trans. Ind. Electron.*, 59: 3604-3613.
- Luo, A., Z. Shuai, W. Zhu and Z.J. Shen, 2009. Combined system for harmonic suppression and reactive power compensation. *Trans. Ind. Elect.*, 56: 418-428.
- Malinowski, M., G. Marques, M. Chichowlas and M.P. Kazmierkowski, 2003. New direct power control of three phase PWM boost rectifiers under distorted and imbalanced line voltage conditions. *Proceedings of the IEEE International Symposium on Industrial Electronics, Volume 1, June 9-11, 2003, Rio de Janeiro, Brazil*, pp: 438-443.
- Malinowski, M., M.P. Kazmierkowski, S. Hansen, F. Blaabjerg and G.D. Marques, 2001. Virtual flux based direct power control of three phase PWM rectifiers. *IEEE Trans. Ind. Applic.*, 37: 1019-1027.
- Oliver, J.A., R. Lawrence and B.B. Banerjee, 2002. How to specify power-quality-tolerant process equipment. *IEEE Ind. Applic. Mag.*, 8: 21-30.
- Peng, F.Z., 1998. Application issues of active power filters. *IEEE Indus. Applic. Mag.*, 4: 21-30.
- Rahmani, S., A. Hamadi, K. Al-Haddad and L.A. Dessaint, 2014. A combination of shunt hybrid power filter and thyristor-controlled reactor for power quality. *IEE*.
- Rahmani, S., Ab. Hamadi, K. Al-Haddad and A.I. Alolah, 2013. A DSP-based implementation of an instantaneous current control for a three-phase shunt hybrid power filter. *Math. Comput. Simul.*, 91: 229-248.
- Rodriguez, P., J. Bergas and L. Sainz, 2002. New PLL approach considering unbalanced line voltage condition. *Proceedings of the IEEE International Conference on Power and Energy Systems, Junary 2002, IEEE.*, pp: 329-334.
- Saetieo, S., R. Devaraj and D.A. Torrey, 1997. TI design and implementation of a three phase active power filter based on sliding mode controller. *Proc. Inst. Elect. Eng. Generation Transm. Distrib.*, 144: 564-568.
- Sensarma, P.S., K.R. Padiyar and V. Ramanarayanan, 2000. A STATCOM for composite power line conditioning. *Proceedings of the IEEE International Conference on Industrial Technology, Volume 2, January 19-22, 2000, Goa*, pp: 542-547.