

## Selective Harmonic Elimination Based Cascaded H-Bridge Eleven Level Inverter Using Particle Swarm Optimization Technique

M.S. Sivagamasundari and P. Melba Mary

Department of EEE, V.V. College of Engineering, Tisaiyanvilai, Tamil Nadu, India

---

**Abstract:** This research study presents a selective harmonic elimination method for a cascaded H-bridge eleven level inverter using the particle swarm optimization technique. The main objective of selective harmonic elimination pulse width modulation strategy is eliminating low-order harmonics by solving non-linear equations. In order to obtain the corresponding switching angles of a eleven-level cascaded H-bridge inverter, a PSO algorithm has been developed to solve the non-linear equations. This proposed PSO algorithm is effective in reducing the total harmonic distortion of cascaded H-bridge eleven level inverter. The simulation results has been carried out using MATLAB/SIMULINK and prove that the PSO algorithm converges successfully to the global solution faster than other algorithms.

**Key words:** Multi-level inverter, cascaded H-bridge multi-level inverter, total harmonic distortion, particle swarm optimization, eleven level inverter, selective harmonic elimination

---

### INTRODUCTION

In recent years, multi-level inverters have become more attractive for researchers and manufacturers due to their advantages over conventional three-level Pulse Width-Modulated (PWM) inverters. They offer improved output waveforms, smaller filter size, lower EMI, lower Total Harmonic Distortion (THD) and others (Carrasco *et al.*, 2006; Agelidis *et al.*, 1997; Kouro *et al.*, 2007; Park *et al.*, 2003; Tolbert and Habetler, 1999; Calais *et al.*, 2001; Choi, *et al.*, 1991; Carrara *et al.*, 1992). The three common topologies for multi-level inverters are as follows: diode clamped (neutral clamped) (Nabae *et al.*, 1981; Pou *et al.*, 2005; Alepuz *et al.*, 2006), capacitor clamped (flying capacitors) (Meynard and Foch, 1992; Kang *et al.*, 2005; Lin and Huang, 2006) and cascaded H-bridge inverter (Marchesoni *et al.*, 1988; Rodriguez *et al.*, 2005; Kou *et al.*, 2006). In addition, several modulation and control strategies have been developed or adopted for multi-level inverters including the following: multi-level sinusoidal (PWM), multi-level selective harmonic elimination and space vector modulation (Kang *et al.*, 2005; Rodriguez *et al.*, 2005).

One of the biggest problems in power quality aspects is the harmonic contents in the electrical system as the distorted wave form affects entire system generally sinusoidal pulse width modulation and space vector pulse width modulation are used for eliminating harmonics (Holmes and Lipo, 2003; Kouro *et al.*, 2007). However, these methods are not eliminate lower order harmonics.

The Selective Harmonic Elimination (SHE) is a well-known technique for generating PWM signals that can eliminate specific low-order harmonics from a voltage waveform generated by a Voltage-Source Inverter (VSI) (Patel and Hoft, 1973, 1974). A fundamental issue associated with such method is to obtain the arithmetic solution of non-linear transcendental equations which contain trigonometric terms and naturally present multiple solutions (Fei *et al.*, 2010). Traditional analytical methods for solving the SHE problem are conducted based on the Newton-Raphson Method. This method requires proper initial values to converge to a proper solution (Fei *et al.*, 2010; Enjeti *et al.*, 1990; Agelidis *et al.*, 2006; Maswood *et al.*, 2001).

Recently, non-traditional methods based on evolutionary algorithms such as Genetic Algorithms (GA) (Sundareswaran *et al.*, 2007; Kavousi *et al.*, 2012), Ant Colony Systems (ACS) (Kennedy and Eberhart, 1995), Bee Algorithms (BA) (Azab, 2009) have been employed for inverter harmonic elimination. Results show that the proposed method does effectively eliminate a great number of specific harmonics and the output voltage is resulted in low total harmonic distortion. In this study, the PSO approach is developed to deal with the SHE problem while the number of switching angles is increased and the determination of these angles using conventional iterative methods as well as the resultant theory is not possible. In addition, for a low number of switching angles, the proposed PSO approach reduces the computational burden to find the optimal solution compared with iterative methods and the resultant theory

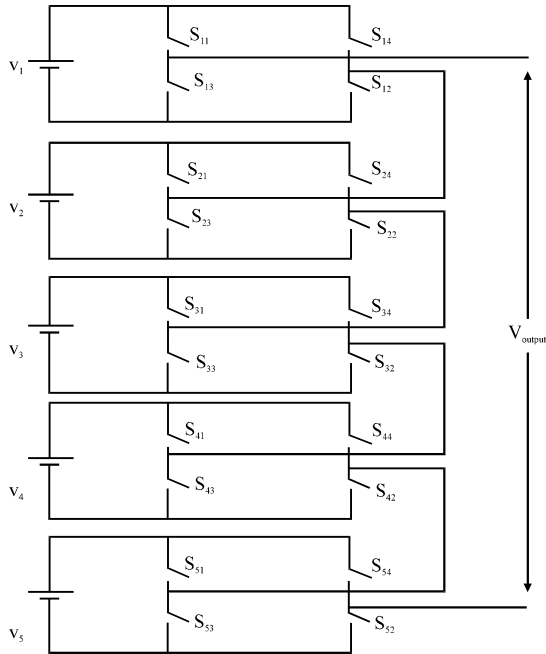

Fig. 1: Schematic of a single-phase cascaded eleven level inverter

approach. The proposed method solves the asymmetry of the transcendental equation set which has to be solved in cascade multi-level inverters. Simulation and experimental results are provided for a 11-level cascaded multi-level inverter to show the validity of the proposed method.

**CASCADEDH-BRIDGE ELEVEN LEVEL INVERTER**

The cascaded multi-level inverter circuit provides high quality output when the number of levels in the output increases and also this reduces the filter components size and cost. Figure 1 shows the schematic of a single-phase cascaded eleven level inverter. Five identical inverter modules are connected in series to form a single-phase 11-level inverter. All modules are fed by DC voltage sources of the same magnitude. The output voltage has 11 voltage levels from  $-5$  to  $+5 V_{dc}$ . The ac outputs of each of the different full-bridge inverter levels are connected in series such that the synthesized voltage waveform is the sum of the inverter outputs. The number of output phase voltage levels  $m$  in a cascade inverter is defined by  $m = 2s+1$  where  $s$  is the number of separate dc sources.

Output voltage waveform for an eleven level cascaded H-bridge inverter with 5 SDCSs and 5 full bridges is shown in Fig. 2. The phase voltage  $v_{an} = v_{a1}+v_{a2}+v_{a3}+v_{a4}+v_{a5}$ .

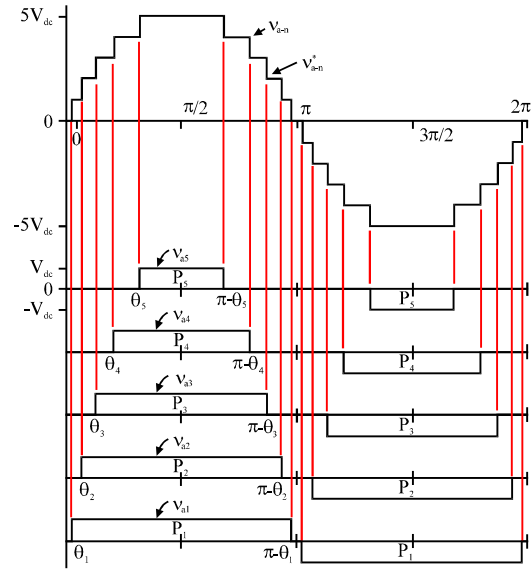

Fig. 2: Output voltage waveform of an eleven level cascaded inverter

**SELECTIVE HARMONIC ELIMINATION**

There are many popular methods used to reduce the harmonics in order to get an effective results. The popular methods for high switching frequency are sinusoidal PWM and space vector PWM. For low switching frequency methods are space vector modulation and selective harmonic elimination. The SPWM technique has disadvantage that it cannot completely eliminate the low order harmonics. Due to this, it causes loss and high filter requirement is needed. Space Vector Modulation technique cannot be applied for unbalanced DC voltages. SHE PWM technique uses many mathematical methods to eliminate specific harmonics such as 5th, 7th, 11th harmonics. The popular Selective Harmonic Elimination Method is also called Fundamental Switching Frequency Based on Harmonic Elimination Theory.

Selective Harmonic Elimination PWM (SHE PWM) technique is used to find appropriate switching angles namely  $\theta_1, \theta_2, \theta_3, \dots, \theta_N$  so that the  $(N-1)$  odd harmonics can be eliminated and control of the fundamental voltage is also achieved. The harmonic components in the symmetric staircase waveform can be describes as follows:

- The amplitude of dc component equals zero
- The amplitude of the fundamental component,  $n = 1$  and odd harmonic component are given by:
  - $h_1 = 4V_{dcnr} \cos \theta k sk = 1$
  - $h_n = 4V_{dcnr} \cos n\theta k sk = 1$
- The amplitude of all even harmonics equals zero

Thus, only the odd harmonics in the quarter-wave symmetric multi-level waveform need to be eliminated. The switching angles of the waveform will be adjusted to get the lowest output voltage THD. In order to control the fundamental amplitude and to eliminate the 5th, 7th, 11th lower order harmonics, the non-linear transcendental equations set (4) must be solved and the five switching angles  $\theta_1, \theta_2, \theta_3, \theta_4$  and  $\theta_5$  are calculated offline to minimize the harmonics for each modulation index in order to have a total output voltage with a harmonic minimal distortion rate:

$$\begin{aligned} \cos \theta_1 + \cos \theta_2 + \cos \theta_3 + \cos \theta_4 + \cos \theta_5 &= 3\pi M/4 \\ \cos 5\theta_1 + \cos 5\theta_2 + \cos 5\theta_3 + \cos 5\theta_4 + \cos 5\theta_5 &= 0 \\ \cos 7\theta_1 + \cos 7\theta_2 + \cos 7\theta_3 + \cos 7\theta_4 + \cos 7\theta_5 &= 0 \\ \cos 11\theta_1 + \cos 11\theta_2 + \cos 11\theta_3 + \cos 11\theta_4 + \cos 11\theta_5 &= 0 \end{aligned}$$

The modulation index for the multi-level waveform is given as:

$$M = h1sV$$

where, h1 is the amplitude of the fundamental component. From equation, varying the modulation index value can control the amplitude of the fundamental component and the other s-1 non-linear equations which are the undesirable harmonic components can be eliminated. These equations are solved by Newton-Raphson Method. In the natural sinusoidal PWM strategy, a large number of switching is required with the consequent increase of switching losses. With the method of Selective Harmonic Elimination, only selected harmonics are eliminated with the smallest number of switching. This technique is very suitable for inverters control. By employing this technique, the low THD output waveform without any filter circuit is possible.

### **PARTICLE SWARM OPTIMIZATION**

Kennedy and Eberhart first introduced PSO in 1995 as a new Heuristic Method (Kennedy and Eberhart, 1995). Basically, the PSO was inspired by the sociological behavior associated with swarms such as flocks of birds and schools of fish. The individuals in the population are called particles. Each particle is a potential solution for the optimization problem and tries to search the best position through flying in a multi-dimensional space. The sociological behavior which is modeled in the PSO system is used to guide the swarm, hence probing the most promising areas of search space. Each particle is determined by two vectors in D-dimensional search space:

the position vector  $X_i = [x_{i1}, x_{i2}, \dots, x_{iD}]$  and the velocity vector  $V_i = [v_{i1}, v_{i2}, \dots, v_{iD}]$  (Azab, 2009). Each particle in the swarm refines its search through its present velocity, previous experience and the experience of the neighboring particles. The best position of particle i found so far is called personal best and is denoted by  $P_i = [p_{i1}, p_{i2}, \dots, p_{iD}]$  and the best position in the entire swarm is called global best and is denoted by  $P_g = [p_{g1}, p_{g2}, \dots, p_{gD}]$  (Hereford and Siebold, 2008). At first, the velocity of the ith particle on the dth dimension is used to modify the position of that particle:

$$\begin{aligned} v_i(k+1) &= \omega v_i(k) + c_1 r_1 [L_{best} - x_i(k)] + c_2 r_2 [G_{best} - x_i(k)] \\ p_i(k+1) &= x_i(k) + v_i(k+1) \end{aligned}$$

where,  $c_1$  and  $c_2$  are the cognitive and social parameters, respectively. In these equations,  $r_1$  and  $r_2$  are random values uniformly distributed within [0, 1]. Unlike other iterative methods, the main advantage of this method is that there will be no initial guess for convergences required (Kennedy and Eberhart, 1995). PSO also has better computational efficiency and exhibits more stable convergence characteristic than other optimization methods.

### **SIMULATION RESULTS**

To validate the computational results for switching angles, a simulation is carried out in MATLAB/SIMULINK Software for a 11-level cascaded H-bridge inverter shown in Fig. 3. This proposed method is the fast convergence and it is easy to implement to get optimum values of desired output. Previous methods work has the complexity nature of solving the selective harmonic elimination equations and gives the slower convergence. This method uses the initial guess values and the objective function, to get the optimum values of switching angles and total harmonic distortion at the same time. The DC source for each H-bridge unit is considered to be 65V. Figure 4 and 5 shows the output voltage and output current waveform. Figure 6 shows the generated gate pulses using selective harmonic elimination control technique to the multi-level inverter switches. From the gate pulse turn on period, it is observed that each switches turned on at different time period to synthesize required output voltage. The FFT analysis for five level h-bridge inverter is shown in Fig. 7. The Simulated value of THD is 22.25%.

From the above simulated, it is observed that the desired low order harmonics are eliminated efficiently and eventually the Total Harmonic Distortion (THD) of the

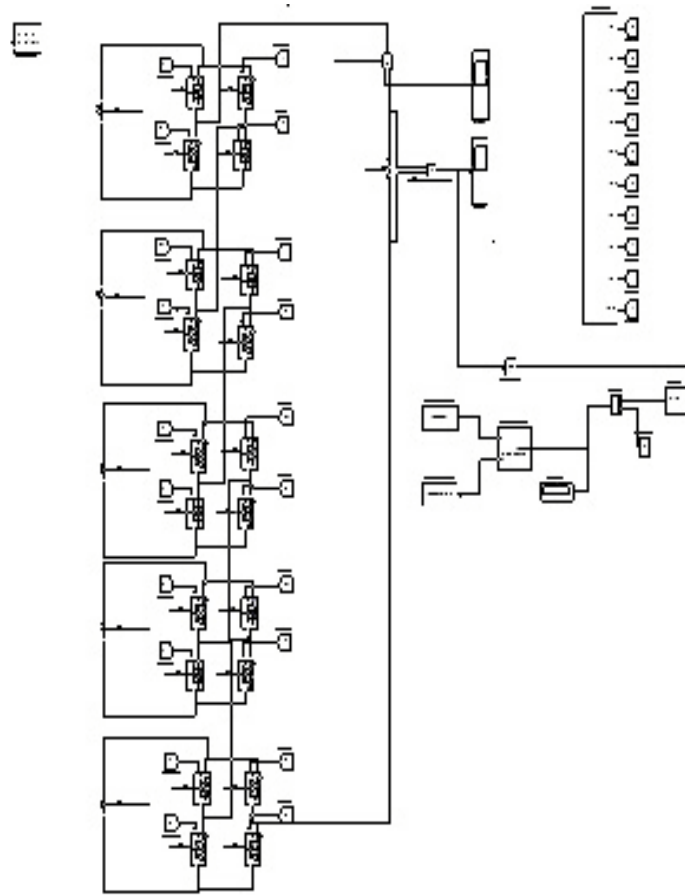

Fig. 3: Simulation circuit of cascaded H-bridge 11-level inverter

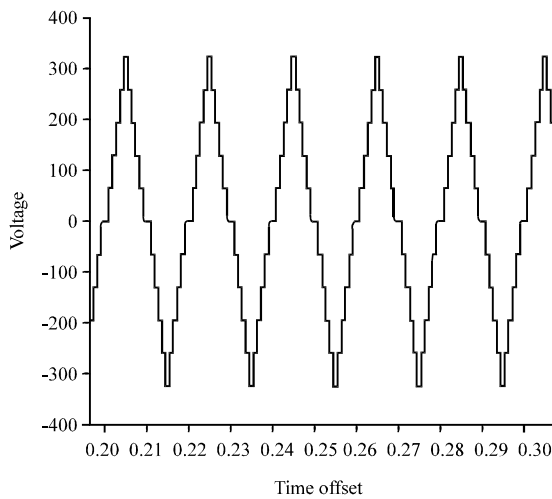

Fig. 4: Output voltage waveform

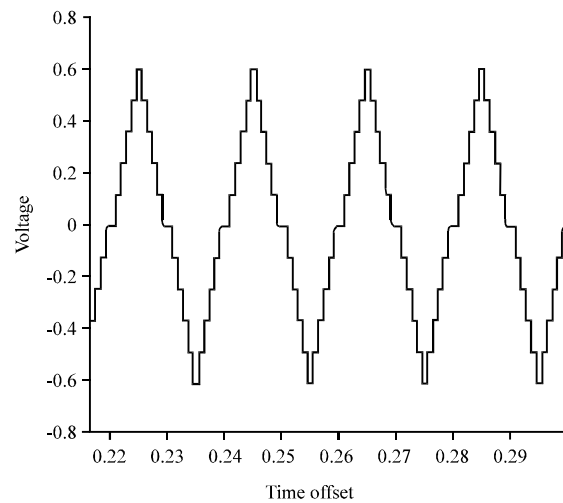

Fig. 5: Output current waveform

output voltage is improved better than the traditional switching schemes and hence, the efficiency of the system will be improved. Therefore, the proficiency of the

proposed switching scheme using PSO algorithm is shown to be better than the conventional switching scheme.

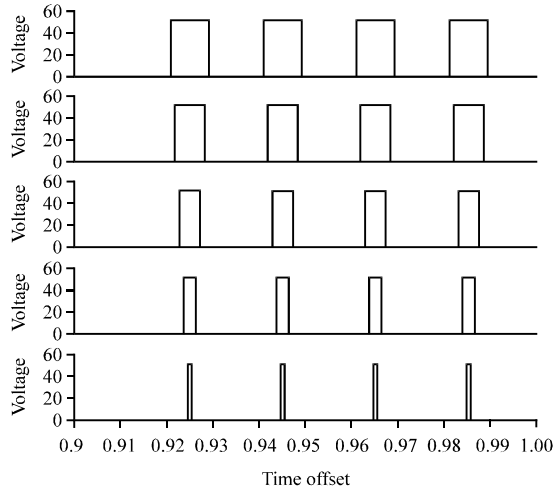

Fig. 6: Gating pulses

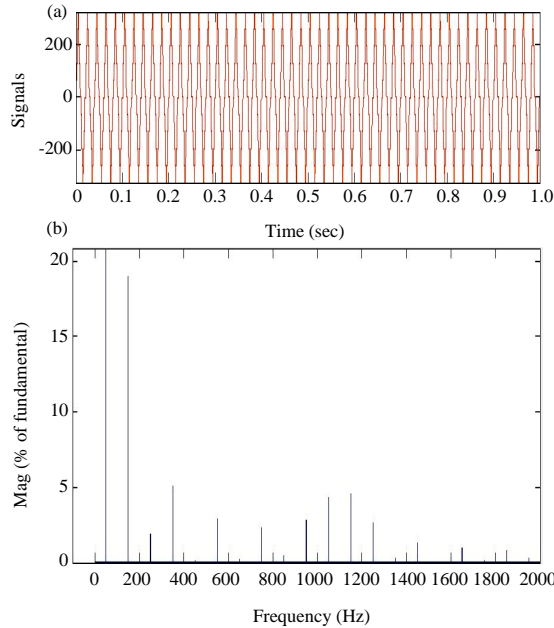

Fig. 7: FFT analysis of eleven level inverters: a) selected signal cycles. FFT window (in red): 50 cycles and b) fundamental (50 Hz) = 249.7, THD = 22.25%

**CONCLUSION**

In this study, selective harmonics elimination technique is used to eliminate the 3rd, 5th, 7th and 9th harmonics and PSO algorithm is used to calculate the value of switching angles and thus switching angles are used to decide the switching pulses for eleven level cascaded H-bridge inverter. The total harmonics distortion is reduced to 22.25% and staircase voltage waveform is obtained which is much closer to sinusoidal

waveform. Therefore, an effective reduction of total harmonics distortion is achieved. The results prove that the PSO algorithm converges successfully to the global solution faster than other algorithms.

**REFERENCES**

Agelidis, V.G., A. Balouktsis, I. Balouktsis and C. Cossar, 2006. Multiple sets of solutions for harmonic elimination PWM bipolar waveforms: Analysis and experimental verification. *IEEE Trans. Power Electr.*, 21: 415-421.

Agelidis, V.G., D.M. Baker, W.B. Lawrance and C.V. Nayar, 1997. A multi-level PWM inverter topology for photovoltaic applications. *Proceedings of the IEEE International Symposium on Industrial Electronics*, July 7-11, 1997, Guimaraes, Portugal, pp: 589-594.

Alepuz, S., S. Busquets-Monge, J. Bordonau, J. Gago, D. Gonzalez and J. Balcells, 2006. Interfacing renewable energy sources to the utility grid using a three-level inverter. *IEEE Trans. Ind. Electron.*, 53: 1504-1511.

Azab, M., 2009. Global maximum power point tracking for partially shaded pv arrays using particle swarm optimisation. *Int. J. Renewable Energy Technol.*, 1: 211-235.

Calais, M., L.G. Borle and V.G. Agelidis, 2001. Analysis of multi-carrier PWM methods for a single-phase five-level inverter. *IEEE Power Electron. Specialists Conf.*, 3: 1173-1178.

Carrara, G., S. Gardella, M. Marchesoni, R. Salutari and G. Sciutto, 1992. A new multi-level PWM method: A theoretical analysis. *IEEE Trans. Power Electron.*, 7: 497-505.

Carrasco, J.M., L.G. Franquelo, J.T. Bialasiewicz, E. Galvan and R.P. Guisado *et al.*, 2006. Power-electronic systems for the grid integration of renewable energy sources: A survey. *IEEE Trans. Ind. Electron.*, 53: 1002-1016.

Choi, N.S., J.G. Cho and G.H. Cho, 1991. A general circuit topology of multi-level inverter. *IEEE Power Electron. Specialists Conf.*, 22: 96-103.

Enjeti, P.N., P.D. Ziogas and J.F. Lindsay, 1990. Programmed PWM techniques to eliminate harmonics: A critical evaluation. *IEEE Trans. Ind. Appl.*, 26: 302-316.

Fei, W., X. Du and B. Wu, 2010. A generalized half-wave symmetry SHE-PWM formulation for multi-level voltage inverters. *IEEE Trans. Ind. Electron.*, 57: 3030-3038.

- Hereford, J. and M. Siebold, 2008. Multi-robot search using a physically-embedded particle swarm optimization. *Int. J. Comput. Intell. Res.*, 4: 197-209.
- Holmes, D.G. and T.A. Lipo, 2003. *Pulse Width Modulation for Power Converters: Principles and Practice*. John Wiley and Sons, USA., ISBN-13: 9780471208143, Pages: 744.
- Kang, D.W., B.K. Lee, J.H. Jeon, T.J. Kim and D.S. Hyun, 2005. A symmetric carrier technique of CRPWM for voltage balance method of flying-capacitor multi-level inverter. *IEEE Trans. Ind. Electron.*, 52: 879-888.
- Kavousi, A., B. Vahidi, R. Salehi, M. Bakhshizadeh, N. Farokhnia and S.S. Fathi, 2012. Application of the bee algorithm for selective harmonic elimination strategy in multi-level inverters. *IEEE Trans. Power Electron.*, 27: 1689-1696.
- Kennedy, J. and R. Eberhart, 1995. Particle swarm optimization. *Proc. IEEE Int. Conf. Neural Networks*, 4: 1942-1948.
- Kou, X., K. Corzine and M.W. Wielebski, 2006. Overdistortion operation of cascaded multi-level inverters. *IEEE Trans. Ind. Appl.*, 42: 817-824.
- Kouro, S., J. Rebolledo and J. Rodriguez, 2007. Reduced switching-frequency-modulation algorithm for high-power multi-level inverters. *IEEE Trans. Ind. Electron.*, 54: 2894-2901.
- Lin, B.R. and C.H. Huang, 2006. Implementation of a three-phase capacitor-clamped active power filter under unbalanced condition. *IEEE Trans. Ind. Electron.*, 53: 1621-1630.
- Marchesoni, M., M. Mazzucchelli and S. Tenconi, 1988. A non conventional power converter for plasma stabilization. *Proceedings of the 19th Annual IEEE Power Electronics Specialists Conference*, April 11-14, 1988, Kyoto, Japan, pp: 122-129.
- Maswood, A.I., S. Wei and M.A. Rahman, 2001. A flexible way to generate PWM-SHE switching pattern using genetic algorithm. *IEEE Applied Power Electronics*, 2: 1130-1134.
- Meynard, T.A. and H. Foch, 1992. Multi-level choppers for high voltage applications. *Eur. Power Electron. J.*, 2: 45-50.
- Nabae, A., I. Takahashi and H. Akagi, 1981. A new neutral-point-clamped PWM inverter. *IEEE Trans. Ind. Appl.*, IA-17: 518-523.
- Park, S.J., F.S. Kang, M.H. Lee and C.U. Kim, 2003. A new single-phase five-level PWM inverter employing a deadbeat control scheme. *IEEE Trans. Power Electron.*, 18: 831-843.
- Patel, H.S. and R.G. Hoft, 1973. Generalized techniques of harmonic elimination and voltage control in thyristor inverters: Part I-Harmonic elimination. *IEEE Trans. Ind. Appl.*, IA-9: 310-317.
- Patel, H.S. and R.G. Hoft, 1974. Generalized techniques of harmonic elimination and voltage control in thyristor inverters: Part II-Voltage control techniques. *IEEE Trans. Ind. Appl.*, IA-10: 666-673.
- Pou, J., R. Pindado and D. Boroyevich, 2005. Voltage-balance limits in four-level diode-clamped converters with passive front ends. *IEEE Trans. Ind. Electron.*, 52: 190-196.
- Rodriguez, J., P.W. Hammond, J. Pontt, R. Musalem, P. Lezana and M. Escobar, 2005. Operation of a medium-voltage drive under faulty conditions. *IEEE Trans. Ind. Electron.*, 52: 1080-1085.
- Sundareswaran, K., K. Jayant and T.N. Shanavas, 2007. Inverter harmonic elimination through a colony of continuously exploring ants. *Ind. Electron. IEEE Trans.*, 54: 2558-2565.
- Tolbert, L.M. and T.G. Habetler, 1999. Novel multi-level inverter carrier-based PWM method. *IEEE Trans. Ind. Applic.*, 35: 1098-1107.