

## 8×8 MIMO System Transmission Characteristics with MC-CDMA Multiplexing for next Generation Mobile System

Jalal J. Hamad Ameen and Jamal A. Hassan  
 Department of Electrical Engineering, College of Engineering,  
 Salahaddin University, Erbil, Iraq

**Abstract:** The need of higher data rate transmission made the researchers in communication systems to continue design systems match this requirement, MIMO System is one of the systems to perform the above requirement, this work deals with performance of 8×8 Multiple Input Multiple Output (MIMO) antenna systems which has been analyzed using MATLAB code, more transmission characteristics has been presented to facilitate for researchers working in this field the need of higher data rate systems specially for next generation mobile systems.

**Key words:** MIMO System, MC-CDMA System, next generation mobile system, data, code

### INTRODUCTION

Unique characteristic in a wireless channel (mobile radio channel) is a multipath fading environment. The signal at the receiver end contains not only the transmitted radio wave, it also includes a large number of reflected radio waves arrived at different times. Delay in the received signal is the result of reflections from the obstacles such as buildings, mountains, vehicles, hills or trees. These reflected delayed waves interfere with direct waves and cause Inter Symbol Interference (ISI) which causes significant degradation of network performance. As the communication system included transmitter and receiver with different antenna allocation, there are a simple category of multi-antenna types: MIMO is the use of multiple antennas at both the transmitter and receiver to improve communication performance

MIMO is the use of multiple antennas at both the transmitter and receiver to improve communication performance. So why need MIMO System? The wireless system before MIMO is been constrained by network capacity which is related with channel quality and coverage. To see how problem occurred, we need to talk about the transmission on a multipath channel. In wireless communication the propagation channel is characterized by multipath propagation due to scattering on different obstacle. The multipath problem is a typical issue in communication system with time variations and time spread. For time variations the channel is fading and caused SNR variations. For time spread, it becomes important for suitable frequency selectivity.



Multi-antenna types		
SISO	Single Input Single Output means that the transmitter and receiver of the radio system have only one antenna	
SIMO	Single Input Multiple Output means that the receiver has multiple antennas while the transmitter has one antenna	
MISO	Multiple Input Single output means that the transmitter has multiple antennas while the receiver has one antenna	
MIMO	Multiple Input Multiple Output means that the both the transmitter and receiver have multiple antennas	

Fig. 1: Multi-antenna types

In an urban environment, these signals will bounce off trees, buildings, etc. and continue on their way to their destination (the receiver) but in different directions. With MIMO, the receiving end uses an algorithm or special signal processing to sort out the multiple signals to produce one signal that has the originally transmitted data (Fig. 1).

### MC-CDMA

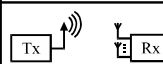
In the MC-CDMA modulator the data stream is first coded, interleaved and modulated into x symbols by BICM block and then the stream obtained is spread in the frequency domain using a spreading code and transmitted on different sub-carriers of the OFDM multiplex (Bhagya *et al.*, 2007). A portion of each original data, corresponding to a chip of the spreading code with length is thus transmitted by each of the sub-carriers (Bhagya *et al.*, 2007; Sahu and Singh, 2012).

In the case of a downlink where the various signals targeting different users are transmitted synchronously, the codes used are generally selected orthogonal which results in receiving a better rejection of interference between users. Thus with Walsh-Hadamard codes, the maximum number of users equals the number of codes. Generally, the number of chips of the spreading code is chosen equal to the number of subcarriers but variants are possible to better adapt the signal to the channel in the case of an OFDM symbol by using an operation of inverse Fourier transform.

### NEXT GENERATION MOBILE SYSTEM

The future mobile system (fourth generation mobile system) will be the expected system which integrates all other mobile systems, the data rate will be about 100 Mbps and 1 Gbps for outdoor and indoor transmission, the coverage for each base station is less than that in 3G systems about one third (about 2-3 km radius), therefore, number of base stations will be higher than that in 3G, some of the key technologies for the system will be MIMO System, Software Defined Radio (SDR), smart antennas this system starts from Long Term Evolution (LTE) through LTE advanced, then 4G Mobile System, this evolution will be through 2x2, 4x4 MIMO then 8x8 MIMO System, therefore, this paper focused on 8x8 MIMO System (Shsrma and Singh, 2013).

### 8x8 MIMO SYSTEM

MIMO technology has attracted attention in wireless communications because of better data throughput and link range without additional bandwidth or transmit power. MIMO achieves this by higher spectral efficiency and link reliability or diversity. MIMO is an important part of modern wireless communication standards such as IEEE 802.11n (Wi-Fi), 4G, 3GPP long term evolution and WIMAX (Bhagya and Ananth, 2011).

In Fig. 2, the channel from transmitter  $i$  to receiver  $j$  represented by  $h_{ij}$ . The envelope of the impulse response of channels follow Rayleigh distribution. The symbols are transmitted in the following manner given in Table 1. Where T denotes transmitter and  $x_i^s$  are QAM modulated symbols. The received vectors can be written in matrix equation form as:

$$Y = HX + N$$

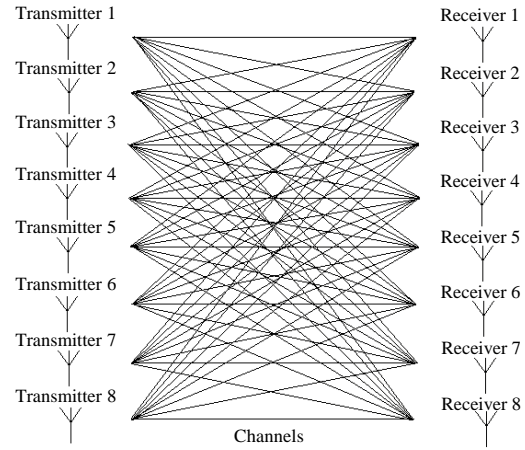

Fig. 2: 8x8 MIMO System

Table 1: Transmission of symbols in MIMO System

Slots	T1	T2	T3	T4	T5	T6	T7	T8
1st time	$x_1$	$x_2$	$x_3$	$x_4$	$x_5$	$x_6$	$x_7$	$x_8$
2nd time	$x_9$	$x_{10}$	$x_{11}$	$x_{12}$	$x_{13}$	$x_{14}$	$x_{15}$	$x_{16}$

$$\begin{bmatrix} y_1 \\ y_2 \\ y_3 \\ y_4 \\ y_5 \\ y_6 \\ y_7 \\ y_8 \end{bmatrix} = \begin{bmatrix} h_{11} & h_{12} & h_{13} & h_{14} & h_{15} & h_{16} & h_{17} & h_{18} \\ h_{21} & h_{22} & h_{23} & h_{24} & h_{25} & h_{26} & h_{27} & h_{28} \\ h_{31} & h_{32} & h_{33} & h_{34} & h_{35} & h_{36} & h_{37} & h_{38} \\ h_{41} & h_{42} & h_{43} & h_{44} & h_{45} & h_{46} & h_{47} & h_{48} \\ h_{51} & h_{52} & h_{53} & h_{54} & h_{55} & h_{56} & h_{57} & h_{58} \\ h_{61} & h_{62} & h_{63} & h_{64} & h_{65} & h_{66} & h_{67} & h_{68} \\ h_{71} & h_{72} & h_{73} & h_{74} & h_{75} & h_{76} & h_{77} & h_{78} \\ h_{81} & h_{82} & h_{83} & h_{84} & h_{85} & h_{86} & h_{87} & h_{88} \end{bmatrix} \begin{bmatrix} x_1 \\ x_2 \\ x_3 \\ x_4 \\ x_5 \\ x_6 \\ x_7 \\ x_8 \end{bmatrix} + \begin{bmatrix} n_1 \\ n_2 \\ n_3 \\ n_4 \\ n_5 \\ n_6 \\ n_7 \\ n_8 \end{bmatrix}$$

where,  $y_i$  is received signal at  $i$ th receiver antenna and  $n_i$  is cumulative AWGN noise at  $i$ th receiver antenna.

### MATLAB System for 8 transmitters and 8 receivers

**(8x8) in 4-QAM:** In this case, 64 channels are involved in every time slot whose channel impulse responses follow Rayleigh distribution, i.e.,  $h = x + iy$  where  $x$  and  $y$  are Gaussian random variables. First generate H matrix (Channel matrix) and then generate X matrix (4-QAM modulated input symbols).  $Y = HX + N$  is the received matrix.

**Decoding of 8x8 uncoded system:** The decoding is done using ZF (Zero Forcing) and VBLAST techniques and the results are compared. A ZF detector is one which generates an estimate of the transmitted matrix as:

$$\hat{X} = \text{pinv}(H) Y$$

Where:

pinv = The pseudo inverse operation

$\hat{X}$  = The estimate of  $X$

$$\begin{bmatrix} \hat{x}_1 \\ \hat{x}_2 \\ \hat{x}_3 \\ \hat{x}_4 \\ \hat{x}_5 \\ \hat{x}_6 \\ \hat{x}_7 \\ \hat{x}_8 \end{bmatrix} = (H^H H)^{-1} H^H \begin{bmatrix} y_1 \\ y_2 \\ y_3 \\ y_4 \\ y_5 \\ y_6 \\ y_7 \\ y_8 \end{bmatrix}$$

i.e., VBLAST can be implemented using ZF, MMSE or MAP rule, here, VBLAST/ZF rule has been implemented which is a variant of VBLASST derived from ZF rule. VBLAST/ZF scheme has been as a successive cancellation scheme derived from the ZF scheme, the ZF rule creates a set of channels by forming:

Where pinv denotes the pseudo-inverse operation, the order selection rule of the algorithm prioritizes the sub-channel with the smallest noise variant, then the algorithm performs ruling and computes decision statistic, slices the computed decision statistic and yields the decision, then cancelation is performed by decision feedback and new pseudo-inverse is computed for the next iteration:

$$\hat{X} = \text{pinv}(H) H | X + \text{pinv}(H) N$$

### VBLAST/ZF algorithm:

Initialization:

$$W_1 = \text{pinv}(H) \\ i = 1$$

Recursion:

$$k_i = \arg \min_{j \in \{k_1, k_2, \dots, k_{i-1}\}} \|(W_j)\|^2$$

$$y_{k_i} = (w_{i,k_i}) y_i$$

$$\hat{x}_{k_i} = Q(y_{k_i})$$

$$r_{i+1} = r_i - x_{k_i} (H)_{k_i}$$

$$W_{i+1} = \text{pinv}(H)_{k_i}$$

$$i = i+1$$

## RESULTS

In this research, 8×8 MIMO System transmission characteristics has been studied in order to be the facility for researchers want to apply in applications like 4G Mobile System, the most important parameter is the Signal to Noise Ratio (SNR) for MIMO System, the relation between SNR and some other parameters is the basic for studying the MIMO characteristic, Fig. 3 is the outage probability versus SNR for Alamouti Space Time

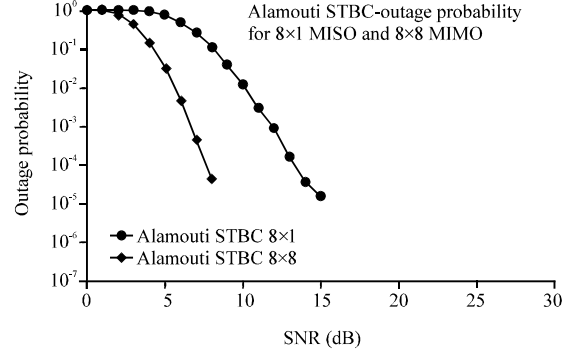

Fig. 3: Outage probability versus SNR for Alamouti STBC 8×1 and 8×8 system

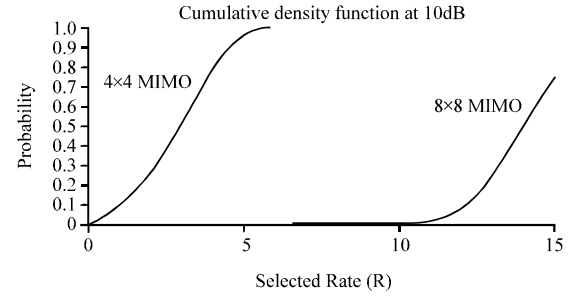

Fig. 4: Cumulative density function probability versus a selected data rate limit

diversity Block Code (STBC) for 8×1 (MISO) and 8×8 MIMO System, it is shown that there is rapid decrease in outage probability in more increase of SNR, this will lead in more improve for the system performance during the data transmission and then higher data rate.

In Fig. 4, the Cumulative Density Function (CDF) probability shown as a function with a selected data rate transmission for both 4×4 and 8×8 MIMO Systems, the great data rate will be for 8×8 compared with 4×4.

Another important parameter is the Ergodic capacity in bit per transmission versus average SNR in FAST Fading rayleigh channel is presented in Fig. 5 for different systems SISO, SIMO, MISO and MIMO System, it is shown that the capacity for that in 8×8 MIMO System is much higher than the others about 5 times, this is very important for MIMO transmission characteristic when applicable in wireless systems specially 4G Mobile System.

**Fast fading Rayleigh channel:** Furthermore, capacity with 10% outage probability versus average SNR in slow fading Rayleigh channel is shown in Fig. 6 for SISO, SIMO, MISO and MIMO Systems, it is shown that more increase in SNR gives higher capacity and more decrease in outage probability for 8×8 MIMO compared to other systems.

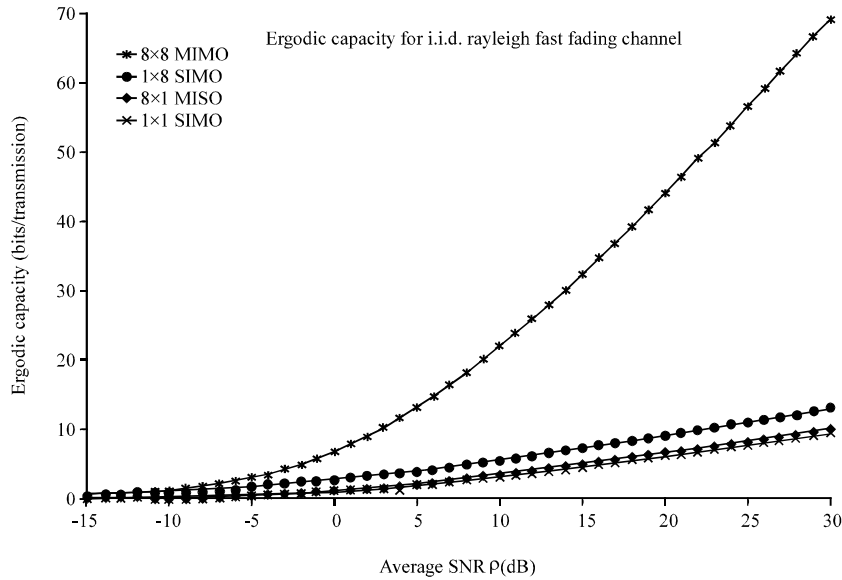

Fig. 5: Ergodic capacity versus average SNR for SISO, SIMO, MISO and MIMO Systems in fast fading Rayleigh channel

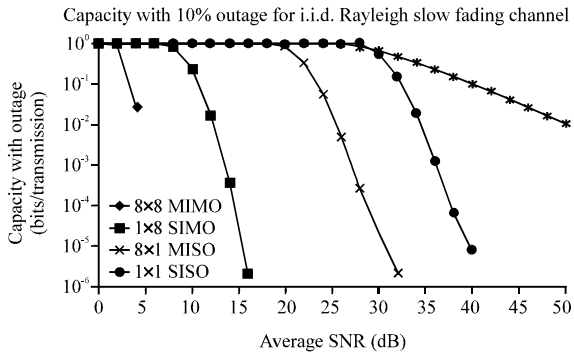

Fig. 6: Capacity with outage probability versus average SNR for SISO, SIMO, MISO and MIMO Systems for slow fading Rayleigh channel

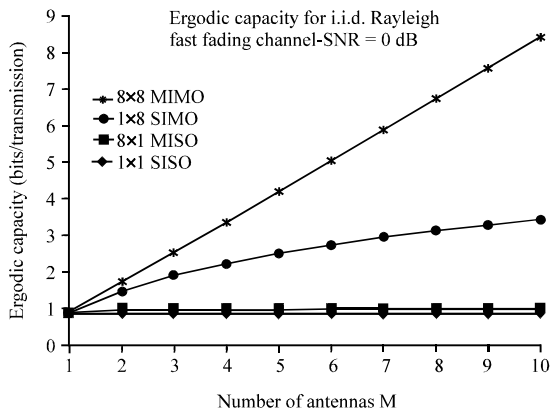

Fig. 7: Ergodic capacity versus number of antennas in fast fading Rayleigh channel for 1x1 SISO, 8x1 MISO, 1x8 SIMO and 8x8 MIMO Systems

Finally, Fig. 7 is the Ergodic capacity versus number of antennas for in fast fading Rayleigh channel for 1x1 SISO, 8x1 MISO, 1x8 SIMO and 8x8 MIMO Systems, it is shown that higher size of MIMO System specially (8x8 MIMO) gives higher Ergodic capacity and then higher data rate transmission.

**CONCLUSION**

This study is an attempt to show the transmission characteristics for 8x8 MIMO Systems as shown in the results the main parameters for MIMO System has been compared between 8x8 MIMO and other systems like MISO, SISO and SIMO, this work results will facilitate for the researchers in this field to design MIMO System specially for that in next generation mobile system which is expected the data rate will be about 1 Gbps in outdoor and 100 Mbps for indoor transmission, unlike that for LTE and LTE advanced for which the MIMO System are 2x2 and 4x4 and for 4G System will be 8x8 MIMO System.

**REFERENCES**

Bhagya, R. and A.G. Ananth, 2011. Study of transmission characteristics of 2x2 mimo system for different digital modulation using of DM and STBC multiplexing techniques and ZF equalizer receiver. Department Telecommun. Eng., 1: 210-213.

Bhagya, R., D.V. Pramodini and A.G. Ananth, 2007. Transmission characteristics of 4x4 MIMO system with OFDM multiplexing and markov chain monte carlo receiver. Int. J. Soft Comput. Engin., 1: 233-237.

Sahu, A.K. and S.S. Singh, 2012. BER performance improvement using mimo technique over Rayleigh wireless channel with different equalizers. *Int. J. Eng. Technol.*, 4: 333-340.

Sharma, P.P. and P.P.V. Singh, 2013. Performance evaluation of v-blast MIMO system in fading diversity using matched filter. *Int. J. Emerging Technol. Adv. Eng.*, 3: 400-405.