

## Design of a Model 150 MWh Wind Generator for Domestic and Industrial Applications in Umudike, South East Nigeria

A.D. Asiegbu and P.L. Aigba

Department of Physics, Michael Okpara University of Agriculture Umudike,  
P.M.B. 7267, Umuahia, Abia State, Nigeria

**Abstract:** A model wind-generator design (UWM-1) structured for use in the Umudike community has been done. Design was based mainly on data from wind studies within the community. With two blade-propellers operating from a hub height of 67m, power in excess of 150MWh per annum is derivable which can be utilized in various forms to support domestic and industrial activities of the community.

**Key words:** Wind, wind generator, model-design, power and propeller

### INTRODUCTION

Since the last decade wind has been one of the leading energy technologies as noted by Robins (2000). Today it is still enjoying tremendous boost (Warren, 2004). In United State for instance, it is hoped that wind power would meet 5% of the national electricity needs by 2020 (Robins, 2000). Single turbines would power individual homes while multiple turbines would be linked up to power whole cities. So far the United States wind industry added 389MW of new generating equipment in 2004 to the nation wide fleet (Robins, 2000). This is enough to serve more than 100,000 average homes. Wind is a clean domestic renewable resource capable of weaning United States from dependence on foreign fuel resources (Warren, 2004). This fact by extension is applicable to other nations. Millais (2005) observed that wind technology has the maturity and global muscle to handle CO<sub>2</sub> emissions.

For many years now, the major source of power within the Umudike community is the national grid. Its dwindling nature has led both individuals and institutions to source additional power supplies from generating plants.

With the increasing population of the community and consequently the increasing demand for power, it is envisaged that these conventional sources alone will no longer be adequate to carry the power requirement of the populace in the near future. Alternative sources have to be considered before the community hits power crisis.

This study therefore, looks into the design of a model 150MWh wind generator known as UWM-1 for domestic and industrial applications.

**Theoretical background:** According to Baily (1997) turbines are machines for generating rotating mechanical power from energy in a stream of fluid. Such energy originally in the form of heat or pressure is converted to velocity energy by passing through a system of stationary and moving blades in the turbines. Thus changes in the magnitude and direction of the fluid velocity are made to produce tangential force on the rotating blades causing them to rotate. A wind turbine is therefore a wind driven machine containing curved blades or vanes inside a wheel set vertically on a revolving shaft (Millias, 2005). Winds or air pressure against the vanes turn the wheel and the rotating shaft may then drive a dynamo to produce electrical power.

A propeller as reported by Borst (1997) is a hub-and-multi-blade device for changing rotational power into thrust power for the purpose of propelling through the air. It is also an assembly of radiating blades around a revolving hub that produces thrust or power (Millias, 2005).

Generally power is defined as work done per second (Morris, 1992). Power derivable from the wind is related to wind velocity and propeller parameters (IEC, 2000). The expression according to report from IEC (2000) is given as:

$$P = \frac{1}{2} \rho A V^3 \quad (1)$$

Where,

- P : Wind power in Watts
- $\rho$  : Air density in  $\text{kgm}^{-3}$
- A : The rotor area of the blade in  $\text{m}^2$
- V : The wind speed in  $\text{ms}^{-1}$

Thus to design a wind machine for any community the wind speed and air density of that community should be known; the area of the blade remains the pre-rogative of the designer.

Aerodynamic design of the blade determines the energy capture potential of the machine. For this type, the airfoil side of the blade faces away from the wind. The ratio of the speed of the tip of the blade to that of the undisturbed wind velocity describes the power coefficient (Odendal, 2004). A generator that operates directly at the turbine speed is extremely desirable (Thresher, 2004). However, the revolution per minute (rpm) obtained from the wind can sometimes be enhanced using mechanical gears.

**MATERIALS AND METHODS**

Materials used for this design include propeller blades, connecting shafts, gears, welding materials, knots, screws, metal plates, etc.

**Design of the machine:** In addition to the physical materials listed, meteorological information of the community such as wind speed and air density (Thresher, 2004) were instrumental to the design. Of help as well, were clues obtained from Thomann’s model of efficient machines (Thomann, 1997).

Of particular interest is Mod-2 which has a two-bladed propeller of 300ft (91.4 m) diameter with a rotor speed of 175 rev/min and driving a 2500kW synchronous generator (Thomann, 1997). It has a hub height of 200 ft (61 m). However, the propeller for the wind machine (UWM-1) selected for this model design is two-bladed like mod-2 but with a diameter of 20 m. The choice of a smaller diameter size much less than that of mod-2 is to reduce the inertial effects of propeller size because wind prevalent in the community is light breeze. An earlier part of this study shows that for such an environment a hub height of at least 67 m is required for the machine to deliver. Also average wind speed at this height is  $5.36 \text{ ms}^{-1}$ . A hub height of 67 m was therefore, selected for this project. Figure 1 shows the block design of the machine. It is a horizontal axis type, capable of driving electrical generator, water pump, wind mill, etc.

In Fig. 1, block 1 represents the wind speed, which is fed into the propeller shown in block 2. The blades are

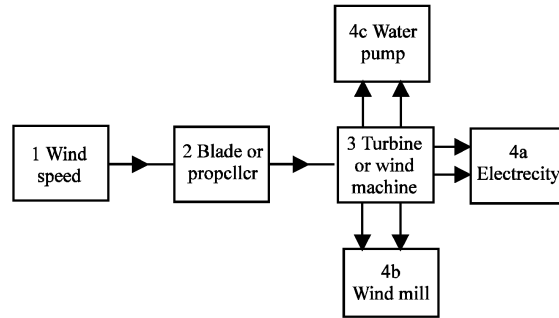

Fig. 1: Block design of the wind machine (UWM-1)

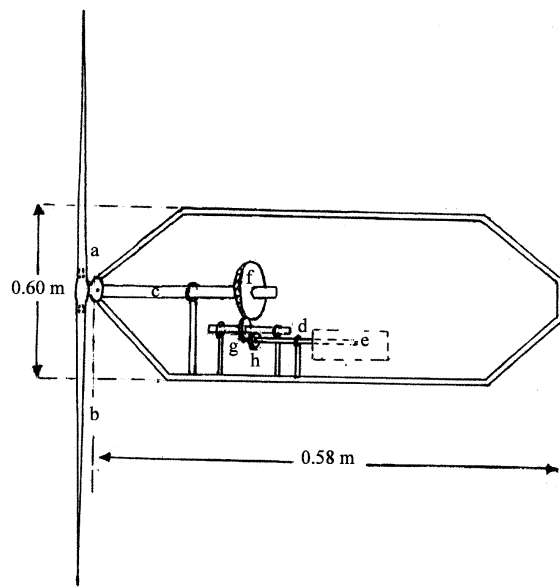

Fig. 2: Major components of UWM-1 design

made of wood with such cutting and shape that provide for pitch angle, airfoil and easy rotation. The machine as shown in block 3 is a combination of the blades and a two-gear system connected by shafts of given diameters. Block 4 is a multi-access, as 4a, b and c representing different pathways to which the output of the machine can be fed to drive a load.

Figure 2 is a section of major components of the design as labeled and specified. In Fig. 2, a and b are propeller blades of 10m length each. C, is a shaft connecting the blades to the driving gear, f, which has a diameter of 0.38 m and 125 teeth. The idler gear g, with a diameter of 0.13 m and 47 teeth is connected to the driven gear h, by means of another shaft d. h, having a diameter of 0.034 m and 10 teeth is connected to the output load via a control device e. The entire assembly is enclosed in a metal casing as shown. Figure 3 shows the mounted machine on a hub height of 67 m.

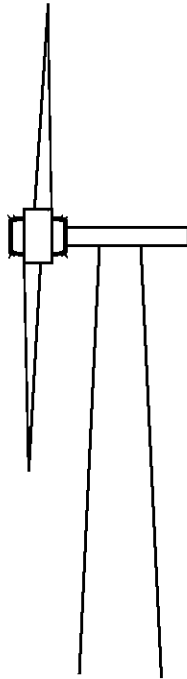

Fig. 3: Mounted version of UWM-1 design

### POWER CONSIDERATIONS

The standard air density  $\rho$  at 760 mmHg and 32°C is 1.21 kg m<sup>3</sup> (Haliday *et al.*, 2001). Area of propeller blade of the design is obtained from  $\Pi r^2$  as  $A = 3.14 \times 10^2$ , giving 314 m<sup>2</sup>. Therefore, applying these values in Eq. 1 for the model, we obtain a wind output power of,

$$\begin{aligned} P &= \frac{1}{2} \rho AV^3 \\ &= \frac{1}{2} \times 1.21 \times 314 \times 5.36^3 \\ &= 29,253.60492W \end{aligned}$$

It is understood that this theoretical power value from the wind will not come out exactly the same when channeled into the wind machine. Losses will occur. Assuming a machine conversion efficiency of 59% known for wind machines, then the actual power derivable from this theoretical value is, 17,259.6269 W. Thus amounting to about 17,260 W of instantaneous power. In a day this will amount to about 414,240 Wh and in a year 151,197,600 Wh which is about 151 MWh per annum. With two or more installations, power in excess of this amount is expected to drive wind mills, electrical turbines, etc.

### CONCLUSION

A model wind generator, UWM-1 has been designed for use in Umudike community. Design was based on well

over ten-year data from the meteorological station of the community on wind studies, furnishing average wind speed, air pressure and temperature of the community (Wind Station, 2005). Design was equally enhanced by wind power report by IEC (2000). The machine is capable of generating power in excess of 150MWh annually. With five such installations a whooping amount of power of about 755MWh is derivable from wind in the community annually.

However, this power figure is not exhaustive as the scope and capacity of power derivable could be increased with more installations. Such amount of power will complement the national grid in supporting industrial and domestic activities

### REFERENCES

- Baily, F.G., 1997. Turbine Propulsion, McGraw-Hill Encyclopaedia of Science and Technology, New York, 18: 687-687.
- Belyeu Kathy and Wegner Ryan, 2005. News from AWEA. Am. Wind Energy Association, www.awea.org, pp: 1.
- Borst, H.V., 1997. Propeller (Aircraft), McGraw-Hill Encyclopaedia of Science and Technology, New York, 4: 467-471.
- Gretz Warren, 2004. Introduction to Wind Energy, Wind Story Text Version, United States Department of Energy.
- Haliday, D., R. Resnick and J. Walker, 2001. Fundamentals of John Wiley and Sons Inc., Replika Press, Pvt Ltd, India, pp: 1144.
- Iowa Energy Center (IEC), 2000. Wind Energy Manual, Iowa Energy Center, pp: 1-9.
- Millias Corin, 2005. EWEA today welcomed the entry into Force of the Kyoto Protocol, as Wind Power is one of the leading global Solutions to Climate Change, European Wind Energy Association.
- Morris, C., 1992. Academic Press Dictionary of Science and Technology. Acad. Press Inc. United States of America, pp: 1783.
- Nelson, M. and P. Parker, 1995. Advanced level Physics, (7th Edn.), CBS Publishers and Distributors, New Delhi, India, pp: 948.
- Odendal, E.J., 2004. Design, Construction and testing of a small Generator with Electronic Controller for Domestic use, University of Natal, Durban, Site Version. www.ctech.uc.za/cont/duesource/web/odendal/odendal.html-37k.
- Patel, R.M., 1999. Wind and Solar Power System, CRC Press, Boca Raton, London.

Robins Jeffery, 2000. Can Wind Power meet our Energy needs? Printer-friendly Version, American Wind Energy Association.

Thomann, G., 1997. Wind Power, McGraw-Hill Encyclopaedia of Science and Technology, New York, pp: 536-538.

Thresher Bob, 2004. Wind Energy, is Real; it's no longer a Dream National Wind Technology Center, National Renewable Energy Laboratory USA.

Wind Station, 2005. National Root Crop Research Institute Umudike, Meterological Center, Umudike, Umuahia, Nigeria.