

## A Technique for Identifying and Characterizing the Microcracks Produced in Machined Surfaces

<sup>1</sup>M. Gaceb and <sup>2</sup>D. Gillibrand

<sup>1</sup>Laboratoire de Fiabilité des Equipements Pétroliers et Matériaux,  
Faculté des Hydrocarbures et de la Chimie, Université M'Hamed Bougara, Boumerdes, Algérie

<sup>2</sup>School of Engineering, University of Sheffield Hallam, United Kingdom

**Abstract:** Microcrack formation constitutes an important feature of the machining process and a fundamental component of the surface integrity of machined components. Microcracks have been observed inside the shear zone and their presence used to explain some aspects of the chip formation process. A preliminary investigation conducted on a number of materials machined under various cutting conditions has confirmed microcrack formation on machined surfaces as a result of machining. There has been, however, no systematic study of these microcracks and their extent, dimensions and the conditions in which they are produced are not well known yet. Bearing in mind that surface microcracks can affect the fatigue, corrosion and other properties of machined components, it is important to devise some means of quantifying this microcrack formation. A technique of microcrack identification and measurement based on Transmission Electron Microscopy (TEM) is described in this study along with its application. Two new parameters, namely the Microcrack Area Ratio (MAR) and the Microcrack Density (MD) are introduced and defined. The extent of microcrack formation on the surface of three different materials machined in the same cutting conditions is examined in the light of this technique. The results show that this technique seems promising and may be adopted in future investigations of microcrack formation on machined surfaces and the factors of influence.

**Key words:** Microcracks, surface integrity, machined surface, transmission electron microscopy

### INTRODUCTION

In recent years, a number of researchers (Iwata *et al.*, 1973; Brown and Luong, 1974, 1975, 1976; Doyle, 1974; Iwata and Ueda, 1971; Hazra *et al.*, 1974; Komanduri and Brown, 1972; Luong, 1977) have reported the existence of microcracks in the primary and secondary deformation zones during machining operations. Microcracks have been used to explain several aspects of material behaviour during machining. Amongst these aspects, for example, are the chip segmentation process (Brown and Luong, 1974), the macro-crack formation in the vicinity of the tool cutting edge by the microcrack coalescence process, and the negative work-hardening phenomenon observed during machining (1975). These works have shown that microcracks often represent a major feature of the deformation zones during machining. This is particularly so with two-phase workpiece materials. Several researchers have reported microcracks present in the primary deformation zone have even been reported (Doyle, 1974) to pass underneath the tool cutting edge into the newly machined surface. Direct electron

microscope observations have shown that machined surfaces also contain a great number of microcracks (Iwata and Ueda, 1971). This has been consolidated in the present study by a preliminary investigation conducted on a number of materials machined under various cutting conditions which has confirmed microcrack formation on machined surfaces as a result of machining

To the present day, however, the microcrack formation in machined surfaces has not been the object of any systematic study, although a few investigators (Gillibrand, 1980; Temple and Ramalingam, 1970) have confirmed the existence of microcracks on machined surfaces. As a result, their size, distribution, morphology and the way they are affected by the cutting parameters are not well known yet. Such a discrepancy is a curious anomaly since it is generally recognized that any evaluation of the surface integrity of a machined component must take into account the eventual existence of surface and sub-surface microcracks (Hazara *et al.*, 1974; Field *et al.*, 1967; Mantle and Aspinwall, 1997).

Despite the various reports on the harmful effects that microcracks may have on the fatigue, corrosion,

resistance, tribological and other properties of mechanical components (McDowell, 1996; Leskovar and Peklenik, 1982; Field and Kahles, 1964; Bailey *et al.*, 1976; Devries *et al.*, 1976) the relationship between the surface microcracks and the functional performance of these surfaces is little known. If such a relationship is to be defined clearly, and the importance of surface microcracks affirmed more astutely, then the evidence would be imperatively required regarding their origin, dimensions and the way they are affected by the machining conditions. It is in this optic thus that a program of study and research has been undertaken with three principal objectives in mind: First the development of a suitable technique capable of supplying precise information on the size, shape and number of the microcracks present on machined surfaces. Second, the investigation of the individual influence of the machining parameters on the process of microcrack formation on machined surfaces. Third, the study of the role of surface microcracks on the functional performance of machined components. This paper is concerned primarily with the first objective. In this respect, a technique based on transmission electron microscopy is presented allowing identification and quantitative evaluation of machined surface microcracks.

**EXPERIMENTAL PROCEDURES**

**Machining tests:** The machining tests were conducted on a Churchill Denhams model Srioiv 22 swing centre lathe with infinitely variable speed control (from 0-2000 rev min<sup>-1</sup>) and a 30 kW power. The workpiece was pre-machined to obtain an annulus of 5 mm thickness at the free end of a cylindrical bar so as to allow orthogonal machining as shown in Fig. 1. Machining was done under dry cutting conditions. The cutting tools used were steel cutting grade P20 carbide tips brazed on a medium carbon tool holder so as to give a 5° rake angle and a 7° clearance angle. Each cutting test was conducted using a freshly ground cutting edge to avoid the eventual effects of cutting tool wear.

The tools were designed to fit in the tool holder of a quick stop device and had a flat at the top of their cylindrical body for positioning and clamping purposes. The quick stop device was driven by a humane killer gun allowing the freeze of the cutting operation by instantly disengaging the tool from the workpiece during machining thus leaving the chip attached to the workpiece as shown in Fig. 2 while keeping the newly machined surface non-destructed by cutting tool retraction and slow stopping of the machining process.

Immediately after the quick stop device had been operated, the spindle rotation was stopped and a squirt of

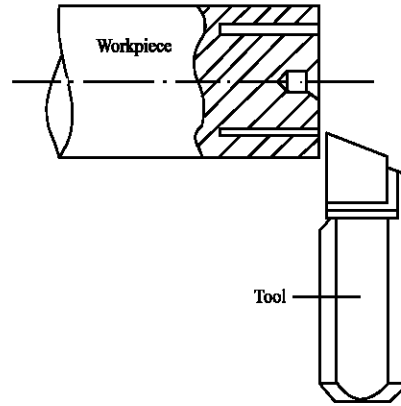

Fig. 1: Orthogonal machining operation

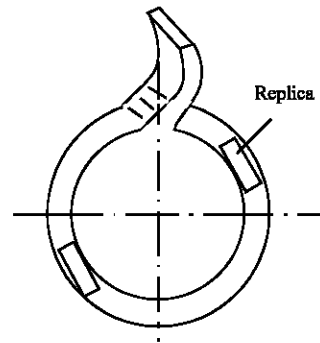

Fig. 2: Machined surface with attached chip

Table 1: Composition of the materials used

Material	C	Mn	Si	S	Pb	P	Cr	Mo
A	0.06	0.90	0.01	0.26	0.24	0.044	0.03	0.01
B	0.41	0.86	0.23	0.054	-	0.027	0.22	0.03
C	0.17	0.51	0.56	0.036	-	0.031	18.22	0.20

A: Free leaded cutting steel B: Medium carbon steel C: Stainless steel

oil was put onto the newly machined surface to preserve it from oxidation and corrosion for subsequent examination and measurement. It was then parted off and numbered using an etching pen for identification later on.

Table 1 shows the chemical composition of three materials which are investigated for surface microcrack characterization and testing of the microcrack measurement technique introduced in this study. The three materials have been machined at a cutting speed of 200 m min<sup>-1</sup> with a feed rate of 0.244 mm rev<sup>-1</sup>.

**Replication of the machined surface:** Prior to replication each machined surface is carefully degreased and washed in acetone before ultrasonic cleaning in trichloroethylene. The surface is then replicated at two random positions around the annulus (Fig. 2). A two stage plastic-carbon replication procedure with gold/palladium (60/40) shadowing was adopted. The replication consists of

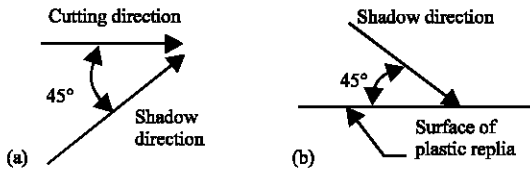

Fig. 3: Shadowing direction: a) with respect to the cutting direction; b) with respect to the machined surface

cutting a piece ( $\approx 20$  by  $30$  mm) of acetate sheet, softening the underside in acetone, laying it on the surface and stripping it once completely dry while avoiding its contamination from dust. The replica is then turned upside down and stuck with sellotape onto a glass slide and labelled for subsequent identification. A shadowing process is then carried out at a  $45^\circ$  angle to the replica surface and  $45^\circ$  to the cutting direction (Fig. 3).

Shadowing is carried out by evaporating gold/palladium (Au/Pd) in a vacuum atmosphere to improve contrast on the final TEM image and to allow quantitative studies of microcracks present on the machined surface. The shadowed replica is then vacuum coated with a thin backing layer of carbon whose role is to strengthen the replica to avoid its rupture during subsequent handling. The carbon coating should not contribute to nor affect the contrast produced by the shadowing process. This is achieved by evaporating the carbon in a normal direction to the replica face, resulting in a carbon film of uniform thickness. The shadowing and carbon coating processes are carried out in the Edwards E306 vacuum coating unit.

The shadowed and coated replica is finally cut into small squares whose size allows them to be mounted on  $3$  mm diameter copper support grids with the carbon coating facing downwards and immersed in acetone to dissolve the plastic substrate leaving the two stage replica of the machined surface. The complete procedure of the TEM specimen preparation is summarized in Fig. 4.

**VISUALIZATION AND IDENTIFICATION OF MICROCRACKS**

The examination of the specimens obtained by the replication procedure is done using the JEOL 100B transmission electron microscope. Unlike the optical microscope which gives an actual picture of the surface, the micrographs obtained should be interpreted in order to be well exploited. This interpretation is based on the contrast obtained which is the result of the intersection between the shadowing process and the machined

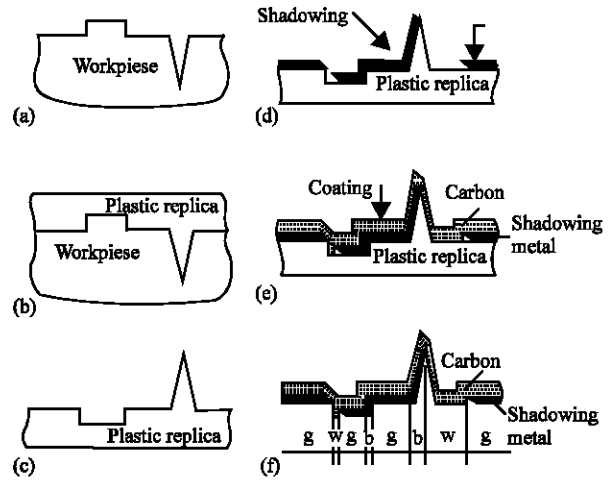

Fig. 4: Surface replication procedures (a) profile to be replicated (b) surface replication (c) plastic replica (d) Au/Pd shadowing (e) Carbon coating (f) Replica with dissolved plastic showing the contrast shade sequence

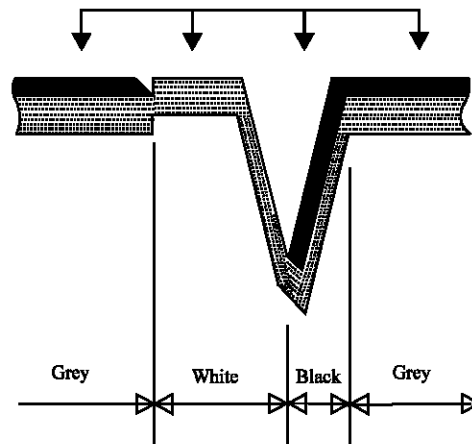

Fig. 5: Contrast shade sequence of a microcrack

surface texture. The shadowing process results in a varying thickness of the metal use which affects electron transmission through the specimen and produces a contrast variation on the micrographs.

Figure 4 (f) shows the contrast shade sequences for a given surface. The sequence for a microcrack is Grey-Black-White-Grey (GBWG) as shown in Fig. 5. A micrograph showing the contrast shade sequence of a microcrack in the shadowing direction is shown in Fig. 6. Given a  $45$  degree shadowing angle to the surface, the measurement of the width of the white shade in the shadowing direction constitutes a direct measurement of the microcrack depth. The arrow indicates the shadowing direction which is also at  $45^\circ$  to the cutting direction.

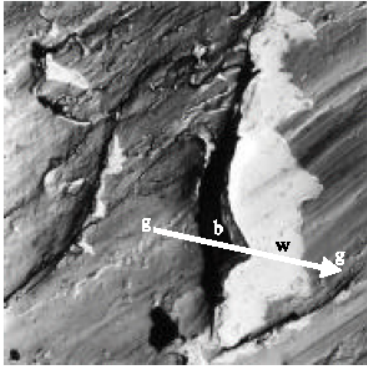

Fig. 6: Micrograph showing the microcrack

**MEASUREMENT OF THE MICROCRACKING**

A number of randomly selected specimens were mounted in a transmission electron microscope and examined at a magnification of 900X. After a preliminary scan around the specimens to acquire some information about the representativity of each individual micrograph, twelve micrographs were randomly obtained for each specimen giving a total of 24 micrographs for each machined surface. The necessary numbers of micrographs being 20, the extra ones are used as replacement in case of damage during negative development. Information and measurements are obtained either from negatives or from photomicrographs.

In the present study the negatives are used for microcrack measurement. The micrographs are randomly considered so as to provide a means of statistical measurement.

**Microcrack Area Ratio (MAR):** The first microcrack measurement parameter is baptized the Microcrack Area Ratio (MAR) and given the symbol  $M_a$ . It is defined as the ratio of the surface area of the microcracks to the surface area of the corresponding machined surface and is given by the general expression:

$$M_a = 100 \cdot \frac{\sum_{i=1}^n A_i}{4788 \cdot n} = (47.88n)^{-1} \sum_{i=1}^n A_i \% \quad (1)$$

where,  $A_i$  is the total area of the microcracks in each micrograph and  $n$  is the number of micrographs whose total surface area can be considered as a representative area of the machined surface.

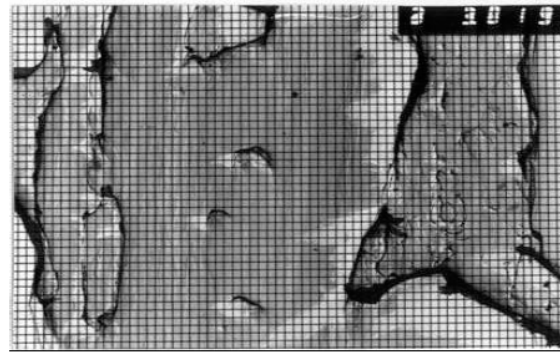

Fig. 7: Grid pattern for MAR measurement

An approximation can be adopted with a less than 0.25% error by the relationship below:

$$M_a = (48n)^{-1} \sum_{i=1}^n A_i \quad (2)$$

To determine the number of micrographs corresponding to a representative area of the machined surface, a convergence study must be done. This consists of measuring the MAR using one, two, three micrographs and so on until it converges to a constant value within a certain level of precision as required. In our case, for the three materials considered, convergence was reached at ten micrographs. The expression for the MAR (Eq. 2) is then given by:

$$M_a = (480)^{-1} \sum_{i=1}^{10} A_i \quad (3)$$

To measure the microcrack area, a grid pattern 84 by 57 mm is superimposed upon the micrograph of the surface under consideration as shown in Fig. 7. The microcrack area is obtained by counting the squares of the grid pattern which fall within the white shade of the contrast pattern corresponding to microcracks. The counting is done manually although it is suggested to do this automatically directly in the transmission electron microscope or using some computer image processing means in future study.

**Microcrack Density (MD):** The number of individual microcracks on a representative of 0.12 mm<sup>2</sup> determined by a convergence study and corresponding to 20 micrographs is adopted as the second parameter and is baptized the Microcrack Density (MD) with a symbol  $M_d$ .

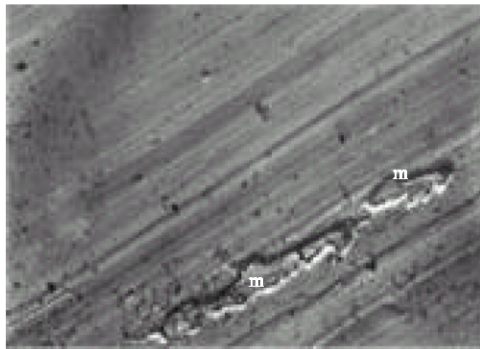

(a)

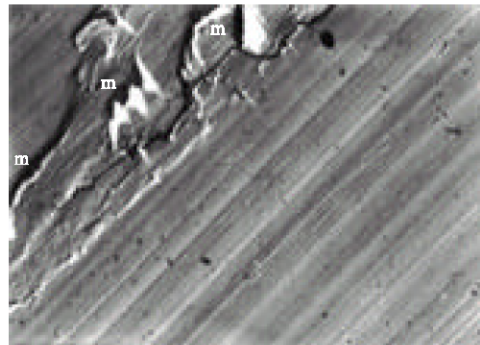

(b)

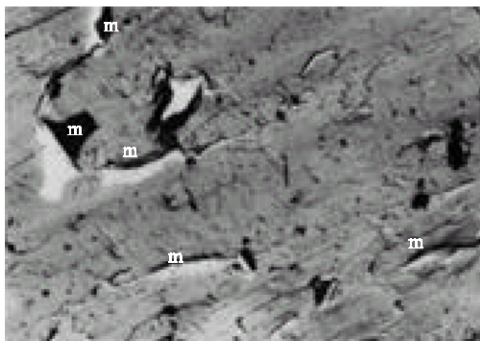

(c)

Fig. 8: Micrograph of the machined surface of (a) The stainless steel (b) The medium carbon steel (c) The free cutting steel

**RESULTS AND DISCUSSION**

The results obtained from the microcrack measurement technique for the three materials machined under similar cutting conditions are shown in tabulated form in Table 2. Both the microcrack area ratio  $M_a$  and the microcrack density  $M_d$  are included. Two specimens for each material are considered. The results for the extra specimen are used in a statistical analysis of the results of the microcrack measurement technique.

To investigate the reliability and repeatability of this measurement technique, two tests of significance are

Table 2: Results of the microcrack measurements (S1 and S2 are the specimens)

Material	A		B		C	
	S1	S2	S1	S2	S1	S2
$M_a$	2.55	2.61	1.42	1.48	0.19	0.21
Number./10	76	69	51	31	27	48
$M_d$	145		82		65	
Mean $M_a$	2.58		1.45		0.20	

applied to the two samples of 10 micrographs of the Microcrack Area Ratio (MAR) and 20 micrographs for the Microcrack Density (MD). The t-student test involves the comparison of the mean difference with its standard error. The f-test is used to compare the variance of the two samples by verifying the null hypothesis (i.e., the samples do not differ in their mean effects). The results of the two tests of significance have shown that there was no significant difference between the two measurements at the 10% significance level.

The results show that the extent of microcracking is greatest for the free machining steel and least for the stainless steel. The number of microcracks however is more or less the same in this case. This seems to suggest that the size of the microcracks decreases from the leaded resulphurized free cutting steel (A) to the stainless steel (C).

Visual confirmation of these results is provided by typical micrographs of the surfaces obtained for the three materials as shown in Fig. 8a-c. The microcracks are designated by the letter m.

**CONCLUSION**

The present study has led to the following conclusions:

- A technique based on the TEM has been successfully used to visualise and identify surface microcracks produced on machined surfaces.
- Two parameters have been introduced and applied to provide a quantitative measurement of the extent (i.e., dimension and distribution) of surface microcracks.
- This technique has been used to explore the influence of workpiece material on the formation of surface microcracks during orthogonal machining. In this case the results suggest that free cutting steel is more prone to microcrack formation than plain carbon or stainless steel.
- Subjected to a statistical analysis based on two comparison tests of significance this measurement technique has proved to be reliable and repeatable.

**REFERENCES**

- Bailey, J.A., S. Jeelani and S.E. Becker, 1976. *J. Eng. Industry*.
- Brown, R.H. and H.S. Luong, 1974. *Annals of the CIRP.*, 23: 7-8.
- Brown, R.H. and H.S. Luong, 1975. *Metals Tech.*, 2: 2-7.
- Brown, R.H. and H.S. Luong, 1976. *Annals of the CIRP.*, 25: 49-52.
- Devries, M.F., M. Field and J.F. Kahles, 1976. *Annals of the CIRP.*, 25: 569-573.
- Doyle, E.D., 1974. In: *Proc. Int. Conf. Prod. Tech. Melbourne*, pp: 161-166.
- Field, M. and J.F. Kahles, 1964. *DMIC Report*, 210: 54-77.
- Field, M., W.P. Koster and J.F. Kahles, In: *Proc. Conf. Manufacturing Tech. ASTM.*, pp: 1319-1336.
- Gillibrand, D., 1980. *Prod. Eng.*, pp: 31-34.
- Hazra, J., S. Ramalingam and D. Cafarelli, 1974. In: *Proceedings of the International Conference on Production Engineering, Tokyo*, pp: 509-515.
- Iwata, K. and K. Ueda, 1971. In: *Proc. Int. Conf. Prod. Eng. Tokyo*, pp: 516.
- Iwata, K., K. Ueda and T. Shibasaki, 1973. *J.S.P.E.*, pp: 183.
- Komanduri, R. and R.M. Brown, 1972. *Metals and Mat.*, 6: 531-533.
- L.M.S., Luong, 1977. In: *Proc. Aus. Conf. Manufacturing Eng. Adelaide*, pp: 122-126.
- Leskovar, P. and J. Peklenik, 1982. *Annals of the CIRP.*, 3: 447-450.
- Mantle, A.L. and D.K. Aspinwall, 1997. *J. Mat. Proc. Tech.*, 72: 413-420.
- McDowell, D. L., 1996. *Int. J. Fracture*, 80: 103-145.
- Temple Black, J.T. and S. Ramalingam, 1970. *International J. Machine Tool Design and Research. Pergamon Press*, 10: 439-463.