

## On the Maximum Efficiency of Induction Motor Drive Using V/I Algorithm

<sup>1</sup>R. Razali, <sup>2</sup>A.N. Abd Alla, <sup>3</sup>M.A. Choudhury and <sup>4</sup>P.K. Shadhu Khan

<sup>1</sup>Faculty of Engineering and Technology, Multimedia University, Melaka, Malaysia

<sup>2</sup>Faculty of Electric and Electronic Engineering, University of Malaysia Pahang, Kuantan, Malaysia

<sup>3</sup>Bangladesh University of Engineering and Technology, Bangladesh

<sup>4</sup>Chittagong University of Engineering and Technology, Bangladesh

**Abstract:** Researchers as well as the industries have great interest in energy efficient operation of Induction Motor Drives (IMD). This can be achieved if the IMD is operated at its maximum efficiency under different loading conditions. In this study, the on-line voltage/current V/I control scheme to operate IMD at its maximum efficiency is introduced. The steady-state per phase equivalent circuit of induction motor is used to derive the V/I reference expressions. The control method requires supplied current, voltage, frequency and motor constants to achieve the maximum efficiency operating region. The V/I algorithm is realized through a control software and single-chip 3-phase AC motor controller, MC3PHAC supervised by Personal Computer (PC). Experimental result shows that V/I ratio under different loading conditions met the targeted value by changing the modulation index. The proposed method is suitable to low horsepower HVAC motors where oversize and/or have a wide load variation.

**Key words:** V/I ratio, maximum efficiency, induction motor, MC3PHAC

### INTRODUCTION

According to the latest survey, more than half of the electricity generated is consumed by the electric motors and since, most of the power-generating systems produces AC, a majority of the motors used throughout the globe are designed to operate on AC, specifically induction motor (Lin and Yang, 2003; Satheesh *et al.*, 2005). The vast majority of the motors used in industry are squirrel-cage induction motors due to their low cost, high reliability. An AC induction motor can consume more energy than it actually needs to perform its work, particularly when operated at less than full-load conditions. Studies conducted by the Electric Power Research Institute reveal that over 60% of industrial motors are operating below 60% of their rated load capacity (Wamock and Kirkpatrick, 1986; Nergaard *et al.*, 2002; Kim *et al.*, 1984). Although, they are generally efficient, idling, cyclic, lightly loaded or oversized motors consume more power than required even when they are not working.

Many control schemes to improve efficiency of induction motor drives under partial load have been reported previously. These schemes can be separated into three categories (Mannan *et al.*, 2002; Ta and Hori, 2001; Ta *et al.*, 2001). The controller measured the input power and then searches for the operating point where the

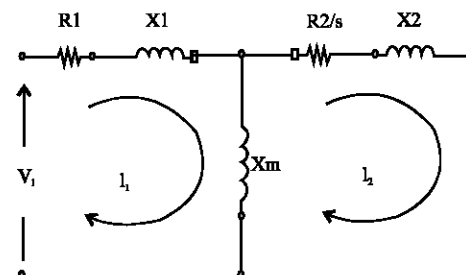

Fig. 1: Induction motor per phase model

input is at a minimum while keeping the motor output power constant. Loss model method. A loss model is required for loss calculation in this scheme then a feedback controller is used to force the motor to operate at its minimum-loss point. Power factor method. When the motor is operating at constant speed, the power factor is adjusted such that the operating loss is minimal.

In this study, the main focus is to operate the IMD closest to voltage/current (V/I) reference corresponding to the maximum efficiency. The reference value of V/I was obtained using slip at maximum efficiency based on the well known per phase steady state model of an induction motor (Fig. 1) and the motor constants. Since, the only information required are stator voltage and current and simplified the steps in achieving maximum efficiency

operation. This method avoiding, power input calculation and minimum input power searching. Loss calculation and minimum loss searching. Minimum current and minimum power searching. Empirical, trial and error in power factor method. Experimental results shows at any loading conditions, the maximum efficiency is easily achieved by operating the SCIM at the V/I reference value.

### CONTROL STRATEGY FOR EFFICIENCY OPTIMIZATION

**V/I and slip at maximum efficiency:** Steady state equivalent circuit of an induction motor and is used to find out the strategy for maximum efficiency (Fig. 1). In Fig. 1, if  $V = V_1$  and  $I = I_1$ , we can write V/I expression by collecting the real parts together and the imaginary parts together as follows:

$$\frac{V}{I} = R_1 + \frac{X_m^2 \frac{R_2}{s}}{\left(\frac{R_2}{s}\right)^2 + (X_2 + X_m)^2} + j \left[ (X_1 + X_m) + \frac{X_m^2 \left[ \frac{R_2}{s} - (X_2 + X_m) \right]}{\left(\frac{R_2}{s}\right)^2 + (X_2 + X_m)^2} \right] \quad (1)$$

Also, the efficiency can be written as:

$$\eta = \frac{(s - s^2) X_m^2 R_2}{s R_2 X_m^2 + R_1 X_m^2 s^2 + R_2 R_1} \quad (2)$$

By taking the derivative of Eq. (2) with respect to  $s$  and let  $d\eta/ds = 0$  and since,  $1/X_2 \gg 2s/X_m^2$  at rated speed, without considering constant losses, once will get maximum efficiency expression as:

$$s_{\eta, \max} = \frac{R_2}{X_m} \sqrt{\frac{R_1}{R_1 + R_2}} \quad (3)$$

Equation (1) showed that all motors parameters are constant except slip,  $s$ . Replacing  $s$  in Eq. (1) with value calculated using Eq. (3), we will obtain the maximum efficiency reference value of V/I. Maintaining the ratio at the set slip will ensure operation of the motor at maximum efficiency.

**Estimation of slip of IMD on real-time operation:** From Eq. (1), V/I in general form can be written as:

$$\frac{V}{I} = \text{Re} + jX_e \quad (4)$$

and dividing the real part by the imaginary part and solve for slip,  $s$ , the on-line estimation for slip can be written as:

$$s = \frac{R_2 (L_e - L_1 - L_m)}{(R_e - R_1) (L_2 + L_m)} \quad (5)$$

If fundamental values of  $V$  and  $I$  can be obtained on-line then V/I can be obtained on-line as well. Furthermore, if motor constants for a particular motor can be determined, the slip and efficiency in Eq. (5) and (3), respectively are also can be obtained in real-time.

### IMPLEMENTATION

The controller uses a commercial 3-phase IGBTs PWM voltage source inverter come with three phase AC-DC converter, a commercial 3-phase AC motor controller, MC3PHAC from Motorola, the interface circuit, the PC, the Data Acquisition card (DAQ) PCI-1710L-B, 100 kS/s, 12 bit from Advantech and a 3 phase, 400 V, 0.34 kW SCIM a controller shown in Fig. 2.

**A MC3PHAC 3-phase AC motor controller:** The MC3PHAC is a 28 pin PDIP, single-chip intelligent controller designed specifically to meet the requirements for low-cost, variable-speed, open loop V/F 3-phase AC motor control system either in stand-alone mode or external master mode is shown in Fig. 3.

To be able to run MC3PHAC in host mode, the circuit shown in Fig. 3 is designed and built. In host mode, the PC via RS 232 serial line used PC master software specifically developed for MC3PHAC, controls and monitors all aspects of MC3PHAC operation through 25 user interface variables.

By changing the commanded frequency the amount of voltage to the motor changes as well according to v/f will lead the motor to work at low frequency. Therefore,

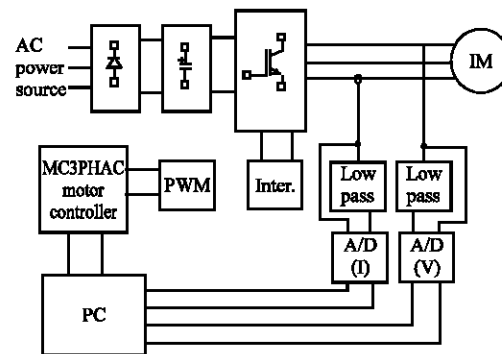

Fig. 2: Experiment setup for V/I control system

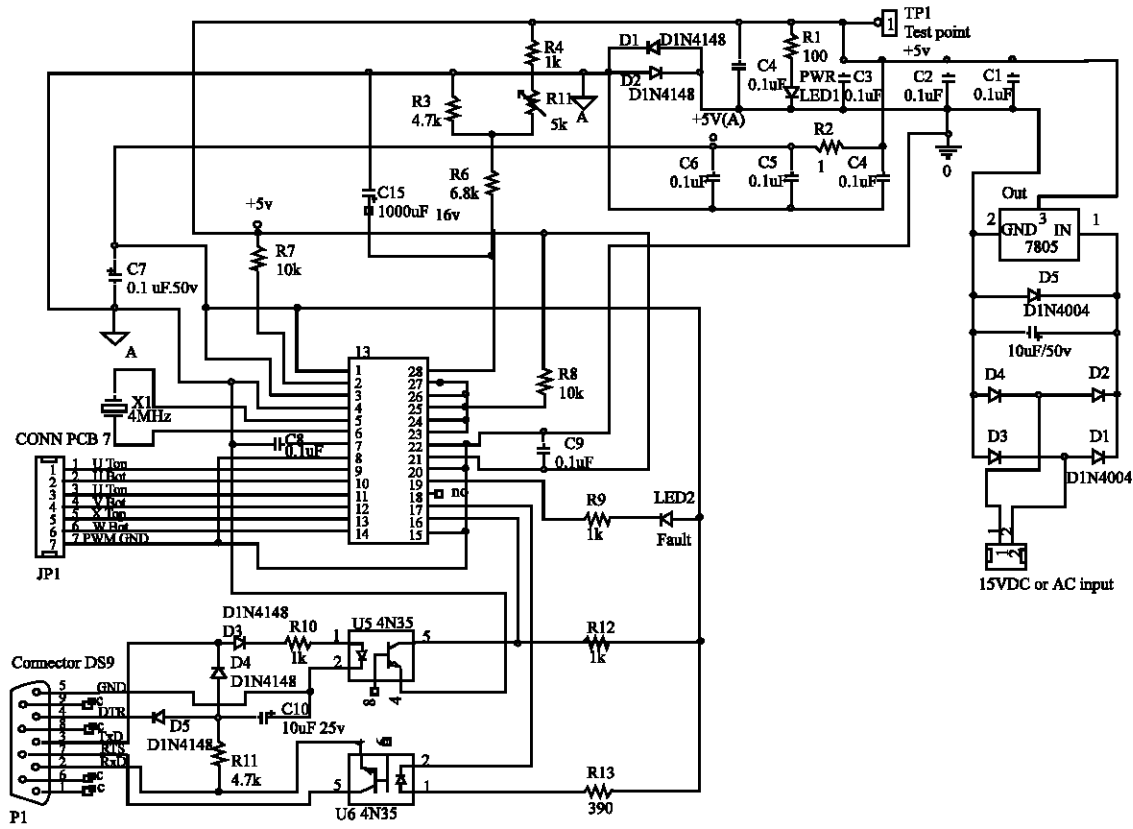

Fig. 3: MC3PHAC host mode configuration with power supply and opto-isolation

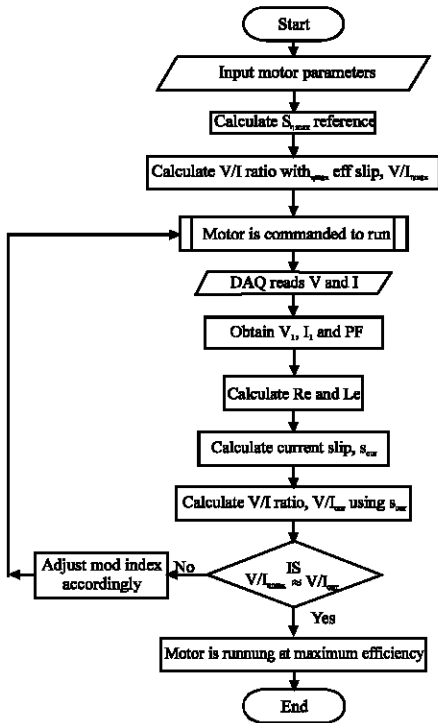

Fig. 4: V/I control software with slip estimation flow diagram

the third control variable, the voltage boost is used to boost the voltage so that the magnetizing current remains to a certain value.

**Control software:** The control software is to create an environment where the motor is running at maximum efficiency. This software with PC Master Software used together to control the MC3PHAC motor controller's variables. The feedback is sensed from output of the inverter in the form of current, voltage and power factor, while the supplied frequency is obtained from MC3PHAC's variable namely actual frequency. The current and voltage are digitized with appropriate sampling frequency using DAQ. Then, the closest V/I is achieved by minimizing the variance between the reference value and recalculated value of V/I through the adjustment of the modulation index by using sequential search method. The control software performs, calculation of reference value of V/I, efficiency, slip, on-line monitoring and controlling of V/I, on-line user interfacing to control the motor operation by controlling the MC3PHAC's control variables and supervising and controlling the generation of maximum efficiency PWM control signals is shown in Fig. 4.

**RESULTS**

The control software was written in Microsoft Visual Basic 6.0 running on PC with Pentium IV processor. The algorithm embedded in the control software used (1), (2) and (3) to first calculate the reference values for V/I ratio, efficiency, slip and subsequently (1), (2) and (5) and feedback in Fig. 3 were used to re-calculate the new V/I ratio, efficiency and slip. The reference values are calculated and listed in Table 1 for the motor mentioned before.

In Fig. 5 and 6, the load is fixed at 400 mN, while modulating frequency is varied starting from 45 Hz down to 25 Hz. At each modulating frequency the stator voltage is adjusted slightly higher than V/I reference value using a 3 phase variac while voltage boosts is set to 0%. Then the voltage is gradually reduced by reducing the

Table 1: Referenced values

V/I ratio	Max. efficiency (%)	Slip
308.91	76	0.0822

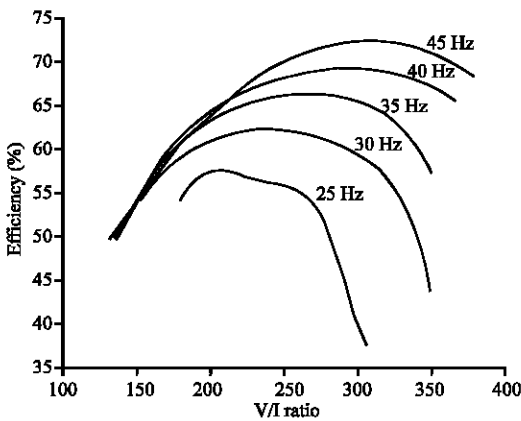

Fig. 5: V/I ratio vs. efficiency at different modulating frequency

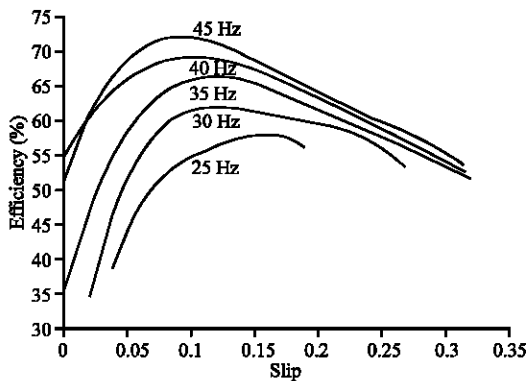

Fig. 6: Slip vs. efficiency at different modulating frequency

MC3PHAC's variable maximum voltage. Figure 7 shows that the maximum efficiency occurs when V/I ratio is in the range of 308-310 for modulating frequency at above 35 Hz. However, at lower modulating frequencies, the maximum efficiency values occurred lower than V/I reference value.

In Fig. 8, the maximum efficiency value occurred when slip is in the range of 0.07-0.09 for modulating frequency ( $f_m$ ) at above 35 Hz. However, at lower  $f_m$ , the maximum efficiency values occurred lower than slip reference value. Experimentally, the efficiency obtained is closely matches with those of theoretically estimated at modulating frequency above 35 Hz. Another significant finding was shown in Fig. 8 and 9. These figures clearly showed that, for a fix  $f_m$  but with different loading condition, the maximum efficiency is achieved at V/I and slip values closed to reference values.

Furthermore, Fig. 6-8 shows process of tracking the maximum efficiency point, the method has identified two operating regions namely high and low efficiency region, respectively.

Other very important relevant experimental results are shown in Fig. 9 and 10. These figures showed that at the maximum efficiency point, the PF automatically and

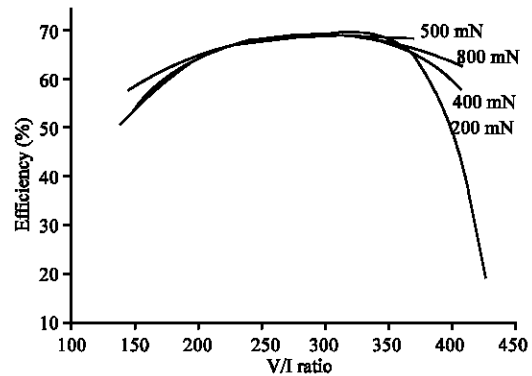

Fig. 7: V/I vs. efficiency at  $f_m = 40$  Hz with different load

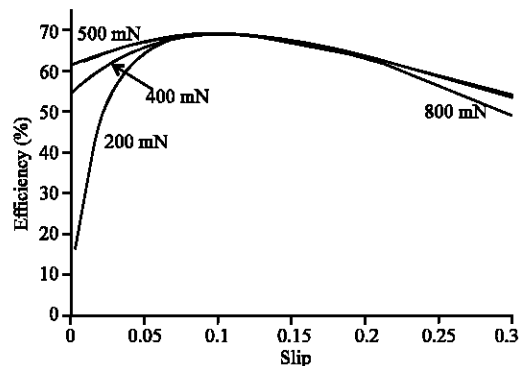

Fig. 8: Slip vs. efficiency at  $f_m = 40$  Hz with different load

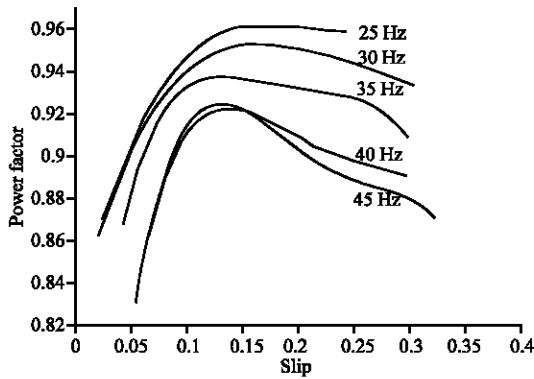

Fig. 9: Power factor vs slip at reduced voltage

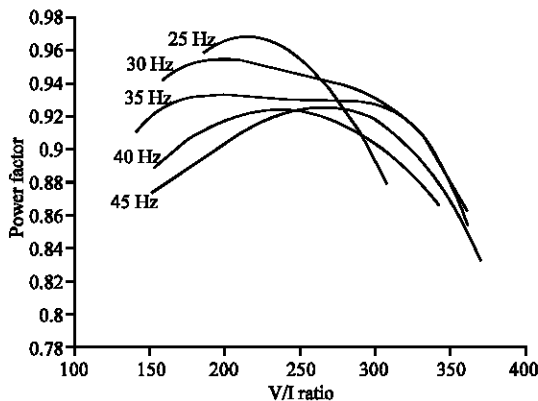

Fig. 10: Power factor vs V/I at reduced voltage

inherently occurred at its optimum value, near the knee of the curves. Therefore, beside successfully monitoring the motor to operate at maximum efficiency the proposed method also indirectly control the PF to its optimum value and hence improved power consumption.

### CONCLUSION

A novel V/I algorithm of achieving maximum efficiency operation of IMD based on a MC3PHAC 3-phase AC motor controller was presented and verified experimentally. The algorithm is coded by using MS Visual Basic 6.0. The experiment set up based in Fig. 3 and 4 was successfully carried out for various loading condition at variable  $f_m$ . The laboratory experiment shows that for lower load than rated load the maximum efficiency is achieved when V/I value of the running motor is close to its V/I reference value. Furthermore, at the maximum

efficiency point the slip and power factor of the motor are automatically adjusted to their optimum values. Also, the new scheme provides information of multiple operating regions, thus provides an option to the operator in selecting other higher efficiency point. However, the V/I algorithm works very well at  $f_m$  above 35 Hz. The proposed method is suitable to low horsepower motors where oversize and/or have a wide load variation.

### REFERENCES

- Kim, H.G. *et al.*, 1984. Optimal Efficiency Drive of a Current Source Inverter Fed Induction Motor by Flux Control. IEEE Trans. Ind. Applied, 20 (6): 1453-1459. DOI: 10.1109/TIA.1984.4504628.
- Lin, F.C. and S.M. Yang, 2003. On-line tuning of an efficiency-optimized vector controlled induction motor drive. Tamkang J. Sci. Eng., 6 (2): 103-110.
- Mannan, A., T. Murata, J. Tamura, T. Tsuchiya, 2002. Efficiency optimized speed control of field oriented induction motor including core loss. Power Conversion Conf. Proc., 3: 1316-1321. DOI: 10.1109/PCC.2002.998164.
- Nergaard, T.A., H.E. Kouns, Jih-Sheng Lai and C.E. Konrad, 2002. Optimal system efficiency operation of an induction motor drive, 2: 826-831. DOI: 10.1109/IAS.2002.1042654.
- Satheesh, B.H.S., N.S. Marimuthu and S. Jeevananthan, 2005. A novel architecture for induction motor performance enhance using VHDL, Coimbatore- 641 013 INDIA; Department of Electrical and Electronics Engineering Government College of Engineering, Academic Open Internet J., pp: 14.
- Ta, C.M. and Y. Hori, 2001. Convergence Improvement of Efficiency-Optimization Control of Induction Motor Drives, IEEE Trans. Industry Applications, 37: 1746-1753, DOI: 10.1109/28.968187.
- Ta, C.M., C. Chakroborty and Y. Hori, 2001. Efficiency Maximization of Induction Motor Drives for Electric Vehicles Based on Actual Measurement of Input Power, pp: 1692-1697. DOI: 10.1109/IECON.2001.975542.
- Warnock, V.J. and T.L. Kirkpatrick, 1986. Impact of Voltage Reduction on Energy and Demand: Phase II. Power System. IEEE Trans., 1 (2): 92-95. DOI: 10.1109/TPWRS.1986.4334910.