

Simulation Investigation of Intake Static Pressure of CNG Engine

¹Semin, ²Abdul R. Ismail and ²Rosli A. Bakar

¹Department of Marine Engineering,

Institute of Technology Sepuluh Nopember, Surabaya 60111, Indonesia

²Faculty of Mechanical Engineering, University Malaysia Pahang, Locked Bag 12,
25000 Kuantan, Pahang, Malaysia

Abstract: The GT-Power one dimension computational model of sequential injection dedicated Compressed Natural Gas (CNG) engine has developed in this study. The engine model is used to simulate the intake gas flow pressure characteristics of diesel engine converted to CNG engine. The computational model considers the steady state and transient simulation processes of the intake port. The engine model size is developed from the real diesel engine data and input to software libraries. The simulation of engine model is running in variations engine speeds from 1000 until 4000 rpm. The simulation results are shown in the graph of this study. Copyright © 2008 Praise Worthy Prize S.r.l. All rights reserved.

Key words: CNG engine, GT-power, intake pressure, one dimensional modelling

INTRODUCTION

This study is discusses the effect of diesel engine convert to CNG engine. In the diesel engines converted or designed to run on natural gas, there are two main options discussed. The first is dual-fuel engines. These refer to diesel engines operating on a mixture of natural gas and diesel fuel. Natural gas has a low cetane rating and is not therefore suited to compression ignition, but if a pilot injection of diesel occurs within the gas/air mixture, normal ignition can be initiated. Between 50 and 75% of usual diesel consumption can be replaced by gas when operating in this mode. The engine can also revert to 100% diesel operation. The second is dedicated natural gas engines. Dedicated natural gas engines are optimized for the natural gas fuel only. They can be derived or converted from petrol engines or diesel engines. The design for dedicated CNG engine is using spark ignition. The engine conversion is has several effect for the engine performance. In this study, the investigation is focused in the intake static pressure effect of diesel engine converted to sequential or multi point injection dedicated CNG engine. The investigation is based on simulation using GT-power software.

For diesel engine engines conversions to CNG engine spark ignition, the pistons must be modified to reduce the original compression ratio and a high-energy ignition system must be fitted. The system is suitable for CNG and

is ideally suited to timed (sequential) port injection system but can also be used for single point and low pressure in-cylinder injection. Gas production provides greater precision to the timing and quantity of fuel provided and to be further developed and become increasingly used to provide better fuel emissions (Poulton, 1994).

The port injection CNG produces negligible levels of CO, CO₂ and NO_x (Suga *et al.*, 2003; Hoekstra *et al.*, 1995; Xu *et al.*, 2005). In order to greatly reduce exhaust gas emissions, a port injection system was chosen by Czerwinski *et al.* (1999, 2003), Hollnagel *et al.* (1999, 2001) and Kawabata and Mori (2004) and the injectors and pressure regulator have been newly developed. At the same time, precise Air-Fuel (A/F) ratio control and special catalysts CNG exhaust gas have been utilized. The resulting CNG engines output power has been restored to near that of the gasoline base engine.

With the Multi Point Injection (MPI) or sequential or trans-intake valve-injection system, a high-speed gas jet is pulsed from the intake port through the open intake valve into the combustion chamber, where it causes effects of turbulence and charge stratification particularly at engine part load operations. The system is able to diminish the cyclic variations and to expand the limit of lean operation of the engine. The flexibility of gas pulse timing offers the potential advantage of lower emissions and fuel consumption. With 3 types of port injectors available on the market, Czerwinski *et al.* (2003) were

compared for stationary and transient engine operation. There are several advantages of port injection, e.g., better possibility to equalize the air-fuel ratio of the cylinders, optimization of the gas injection timing and of the gas pressure for different operating conditions. The port injection has an injector for each cylinder, so, the injectors can be placed in close proximity to the cylinder's intake port. It also enables fuel to be delivered precisely as required to each individual cylinder (sequential) and enables more sophisticated technologies such as skip-firing to be used. Skip-firing is when only some of the cylinders are operating (the other cylinders are being skipped). This enables even more efficient use of the fuel at low loads, further lowering fuel consumption and unburned hydrocarbon (Czerwinski *et al.*, 2003; Zastavniouk, 1997).

The internal combustion engine performance theory to link together with computer modeling of the engine thermodynamics in engine simulations are great challenge, as the latter make the most complete use of the former and the use models is becoming widespread. Engine modeling is a very large subject, in part because of the range of engine configurations possible and the variety of alternative analytical techniques or sub-models, which can be applied in overall engine models (Challen and Baranescu, 2003). Engine modeling is a fruitful research area and as a result many universities have produced their own engine thermodynamics models, of varying degrees of complexity, scope and ease to use. There are also now available a number of fairly comprehensive models, which have a wider, more general purpose use with refined inputs and outputs to facilities their use by engineers other than their developers, most of these models had their origins in university-developed models. They include WAVE from USA, PROMO from Germany, TRANSEG/ICENG/MERLIN from UK, among others. A new code covering complete engine systems have emerged recently, GT-Suite (Challen and Baranescu, 2003). GT-power is one of GT-Suite software applications. GT-Power code can be coupled with an external model (Riegler and Bargende, 2002; Parvate-Patil *et al.*, 2003, 2004; Narayanaswamy and Rutland, 2004). GT-Power is the leading engine simulation tool used by engine and vehicle makers and supplier and is suitable for analysis of a wide range of engine issues. GT-power is designed for steady state and transient simulations and can be used for analysis of engine performance. It is applicable to all types of internal combustion engine and provides the user with many components to model any advanced concept (Gamma Technologies, 2004).

According to Gamma Technologies (2004), GT-power is based on one-dimensional gas dynamics, representing

the flow and heat transfer in the piping and in the other components of an engine system. In addition to the flow and heat transfer capabilities, the code contains many other specialized models required for system analysis. GT-power has the capability to model all aspects of the engine. By being comprehensive, the code is well suited for integration of all aspects arising in engine development. GT-Power is feature an object-based code design that provides a powerful model building facility and reduces user effort. Model are build by a highly versatility graphical user interface common to all other product that simplifies the task of managing object libraries and building, editing, executing and post-processing models. GT-power minimizes the amount of input data entry, as only unique geometrical elements must be defined; this reduces required data input. Model is built by this point and click from a library of user defined reusable objects (Narayanaswamy and Rutland, 2004).

In an application, GT-Power can be used for a wide range of activities relating to engine design and development. Typical applications include manifold design and tuning, valve profile and timing optimization, turbocharger matching, EGR system performance, manifold wall temperature, CFD studies conjunction with star-CD, thermal analysis of cylinder components, combustion analysis, design of active and passive control systems, intake and exhaust noise analysis, design of resonators and silencers for noise control and transient turbocharger response (Gamma Technologies, 2004).

GT-power can be used to predict either steady-state conditions or transient behavior of engine systems. Output include time variation of quantities such as flow rate and flow velocities in all passages, temperature in the system, pressure in the system, component temperatures, engine volumetric efficiency, engine power, engine torque, DI diesel and SI predictive burn rate models, SI NO_x and knock, DI diesel NO_x and soot, catalyst chemistry, heat transfer, calculation of noise at an external microphone, transient noise, pass-by noise and octave band analysis (Gamma Technologies, 2004).

In this study, the GT-power one dimension computational model of sequential injection dedicated Compressed Natural Gas (CNG) engine will be developed. The GT-power engine computational model is used to simulate the intake gas flow pressure characteristics of diesel engine converted to CNG engine. The simulation will be run on 100 iteration and the engine will be run on 1000-4000 rpm.

CNG engine simulation development: The computational simulation development and investigation of gaseous fuel

injector improvement of port injection dedicated CNG engine spark ignition is using GT-power software. Most of the data components and objects from the port injection dedicated CNG engine spark ignition are used in the gaseous fuel injector improvement computational modeling. The difference data components objects are injector nozzle holes, injection timing and injection pressure. The injector nozzle is improved usage multi holes geometries. The gas injection timing is made later and faster than the standard injection timing. The pressure injection is increased than the standard injection pressure.

The model is start from intake environment and finish in exhaust environment as same as the port injection dedicated CNG engine spark ignition computational simulation development. The difference is in the injector object data. The detail of computational simulation of gaseous fuel injector improvement of port injection dedicated CNG engine spark ignition development and investigation is shown in Fig. 1. First activity is open the template library of GT-power software. Second activity is copy, the injector templates and objects in the library. Third activity is define the injector improvement objects folder were copied. Fourth activity is placing the objects of injector improvement. Fifth activity is modification part-override such as components and connections of injector improvement. Sixth activity is connecting component parts of injector improvement. Seventh activity is input the injector improvement new data. Eighth activity is preparation to run the gaseous fuel injector improvement of port/sequential injection spark ignition natural gas engine computational simulation model. Ninth activity is running the gaseous fuel injector improvement of 4 stroke port/sequential injection spark ignition natural gas engine computational model simulation. Tenth activity is view the gaseous fuel injector improvement of 4 stroke port/sequential injection spark ignition natural gas engine computational simulation results. Eleventh activity is analysis and discussion the effect of gaseous fuel injector improvement on MPI natural gas engine computational simulation results. Twelfth activity is conclusion.

The diesel engines converted or designed to run on dedicated or monofuel port injection natural gas engines spark ignition are optimized for the natural gas fuel is shown in Fig. 2. They can be derived from spark ignition engines or may be designed for the purpose. Until Original Equipment Manufacturer (OEM) engines are more readily available, however, the practice of converting diesel engines to spark ignition CNG engine will continue, which involves the replacement of diesel fuelling equipment by a gas sequential injection system and the addition of an ignition system and spark plugs.

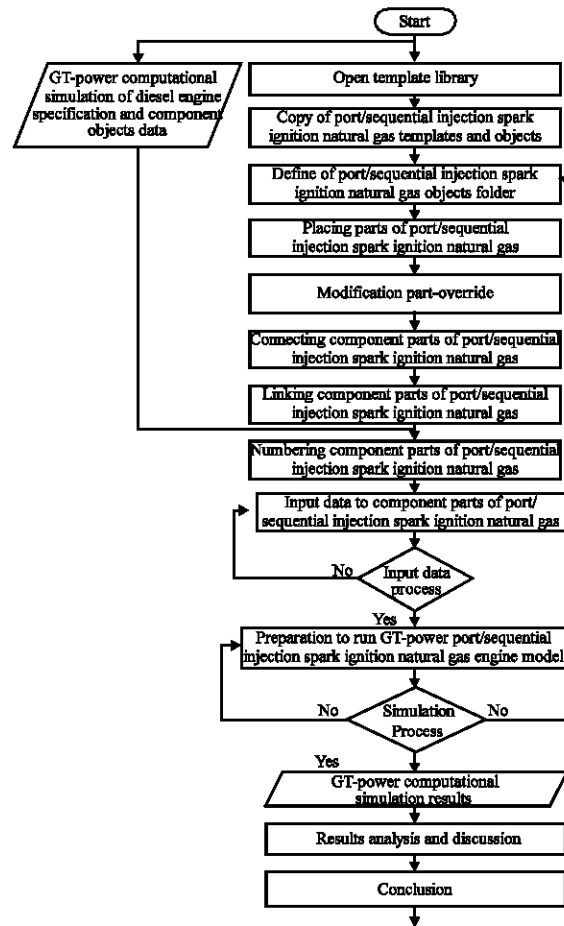

Fig. 1: Flowchart of port injection dedicated CNG engine spark ignition computational simulation development

In the port injection, CNG engine model is added intake pipe and throttle, then fuel is injected using injector in intake port. Intake port is modeled using 9, engine cylinder is modeled using 11 and engine is modeled using 12, then Valve*Conn and EngCylConn connection objects. Nine is used to define the basic geometry and characteristics of intake port, 11 and 12 are used to define the basic geometry and characteristics of engine. These objects further refer to several reference objects for more detailed modeling information on such attributes as gas flow temperature.

The intake system object for CNG engine are environment, intake pipe1, air cleaner, intake pipe2, throttle, intake pipe3, intake runner, injector, intake port and intake valve. In the intake system of the CNG engine, 1 is intake environment, 2 is intake pipe1, 3 is air cleaner, 4 is intake pipe2, 5 is throttle, 6 is intake pipe3, 7 is intake runner, 8 is fuel injector, 9 is intake port, 10 is intake valve.

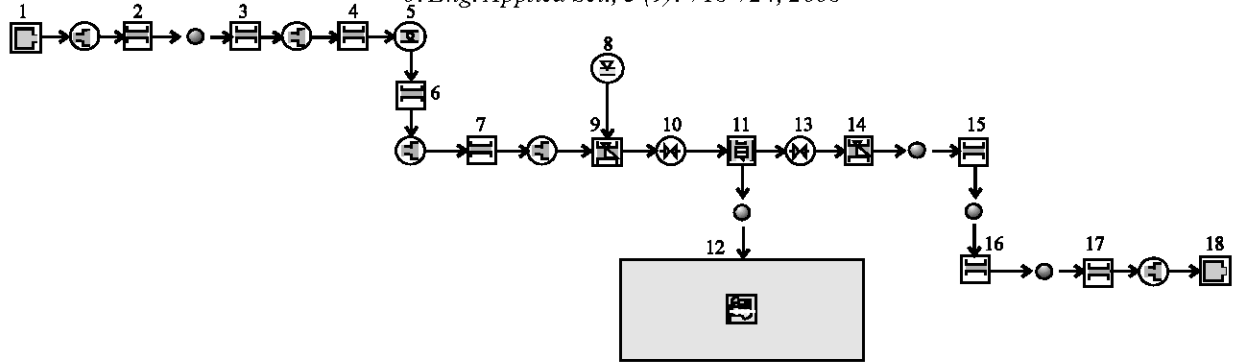

Fig. 2: Multi point injection CNG engine computational modeling parts connected and linked

In CNG engine, engine and cylinder system is focused in engine and cylinder performance supported by gas fuel mixture with fresh air from intake system and exhaust gas to exhaust system. There are 2 components in the engine and cylinder in the CNG engine, but the basic for all diesel engines is the same component. The components are engine cylinder and engine cranktrain. The components size and data must be record and inserted to the GT-power form. In the engine and cylinder system components of CNG engine, 11 is engine cylinder and 12 is engine crank train. Every component in this system, they need any data to complete the data form.

In the exhaust system of CNG engine, started from exhaust valve and finished in the environment. The GT-power components in the exhaust system are exhvalve, exhport, exhrunner, muffler, exhpipeexit and environment. In the exhaust system components, 13 is exhaust valve, 14 is exhaust port, 15 is exhaust runner, 16 is muffler, 17 is exhaust pipe and 18 is exhaust environment. Every component in the exhaust system needs any data to complete the data form and running the model.

RESULTS AND DISCUSSION

The sequential or multi point injection dedicated CNG engine has an injector for each cylinder, so the injectors can be placed in close proximity to the cylinder's intake port. It also enables fuel to be delivered precisely as required to each individual cylinder (called sequential) and enables more sophisticated technologies such as skip-firing to be used. Skip-firing is when only some of the cylinders are operating and the other cylinders are being skipped. This enables even more efficient use of the fuel at low loads, further lowering fuel consumption and unburned hydrocarbon emissions. The gas fuel, usually injected at high velocity as one or more jets through small orifices or nozzles in injector tip, via intake port into the combustion chamber. The gas fuel mixes with high temperature and high pressure air in cylinder. The air is

supplied from intake port of engine too. Since, the air and gas temperature and pressure are near the ignition point, spark ignition of portions of the already-mixed gas fuel and after air a delay period of a few crank angle degrees. The cylinder pressure increases as combustion of the gas fuel-air mixture occurs.

The intake port gas flow investigation in this study, is the intake port pressure. The computational simulation investigation is running in 1000-4000 rpm with interval 500.

To determine the temperature flow through a pipe and constriction is needed the orifice Eq. 11. The stagnation or total temperature T_t at any point in a flow is given by Eq. 1:

$$c_p T_t = c_p T + \frac{v^2}{2} \quad (1)$$

where:

T_t = The temperature that the gas flowing at velocity (v) with static temperature (T) would reach if it were brought to rest adiabatically, the equation is simply an energy balance

$c_p T$ = Being a measure of the static energy

$v^2/2$ = The kinetic energy

$c_p T_t$ = The total energy or enthalpy

Relationship of total to static temperature is obtained using Eq. 2 and using Eq. 3.

$$\frac{T_t}{T} = 1 + \frac{v^2}{2c_p} = 1 + \frac{\gamma R T M_a^2}{2c_p} \quad (2)$$

$$\frac{T_t}{T} = 1 + (\gamma - 1) \frac{M_a^2}{2} \quad (3)$$

The total static pressure equation is shown in Eq. 4. The total static pressure will be increase if the total temperature in any point T_t and gas flow velocity (v) is increase.

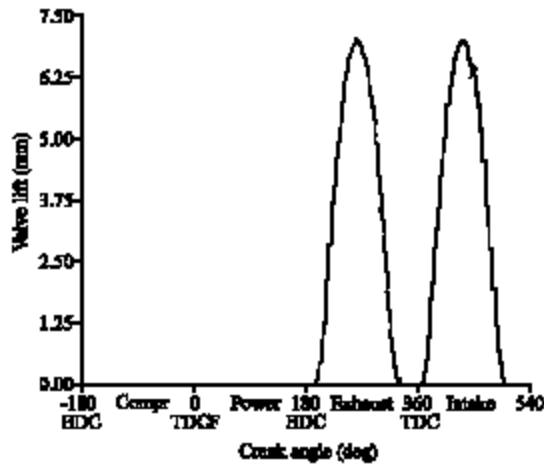

Fig 3: Intake and exhaust valve lift of CNG engine and diesel engine

$$\frac{P_1}{P} = \left(\frac{T_1}{T}\right)^{\frac{\gamma}{\gamma-1}} = \left[1 + \left(\frac{\gamma-1}{2}\right)M_a^2\right]^{\frac{\gamma}{\gamma-1}} \quad (4)$$

Both of sequential or multi point injection dedicated CNG engine and diesel engine are operated in the same valve timing. So, the valve timing profile both of the engine is same. The valve lift profile both of the diesel engine and CNG engine is shown Fig 3.

In the diesel combustion, the fuel injection start is in -22.0 crank angle degree, then the combustion start is in -21.1 crank angle degree. In the sequential injection CNG engine, the combustion is start in -21.1 crank angle degree, where, it is same with diesel engine, but the gas fuel is injected follow the intake valve lift profile, where the fuel injection process is started in 30.4 BTDC and the injection duration is in 7.4 crank angle degree.

The static pressures characteristics in intake manifold pressure profile of 4 stroke sequential injection CNG engine compare with direct injection diesel engine are shown in Fig 4-10. The investigation results are focused in intake port static pressure in variation engine speeds based on crank angle engine stroke and valve lift. Figure 4 shows the CNG engine compared with base diesel engine intake port static pressure versus crank angle profile at 1000 rpm engine speeds. Figure 5 shows the CNG engine compared with base diesel engine intake port static pressure versus crank angle profile at 1500 rpm engine speeds. Figure 6 shows the CNG engine compared with base diesel engine intake port static pressure versus crank angle profile at 2000 rpm engine speeds. Figure 7 shows the CNG engine compared with base diesel engine intake port static pressure versus crank angle profile at 2500 rpm engine speeds. Figure 8 shows the CNG engine

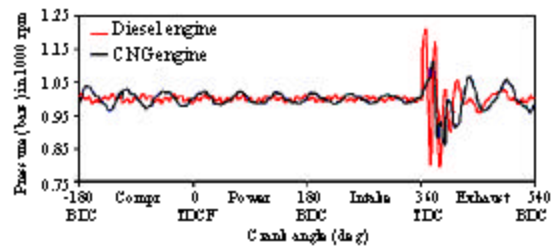

Fig 4: CNG engine and diesel engine intake port static pressure in 1000

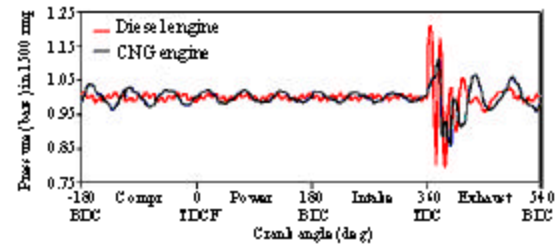

Fig 5: CNG engine and diesel engine intake port static pressure in 1500 rpm

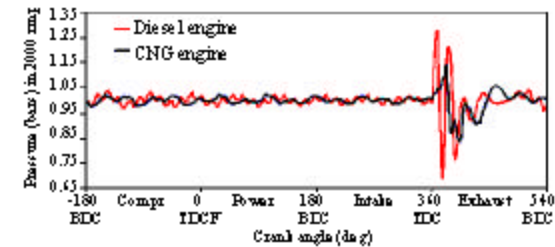

Fig 6: CNG engine and diesel engine intake port static pressure in 2000 rpm

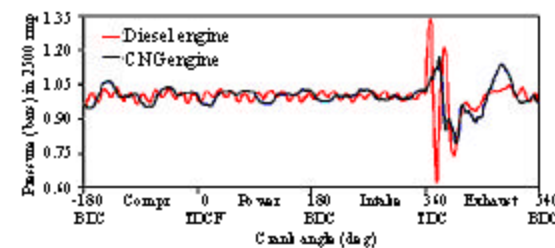

Fig 7: CNG engine and diesel engine intake port static pressure in 2500 rpm

compared with base diesel engine intake port static pressure versus crank angle profile at 3000 rpm engine speeds. Figure 9 shows the CNG engine compared with base diesel engine intake port static pressure versus crank angle profile at 3500 rpm engine speeds. Figure 10 shows the CNG engine compared with base diesel engine intake port static pressure versus crank angle profile at 4000 rpm engine speeds.

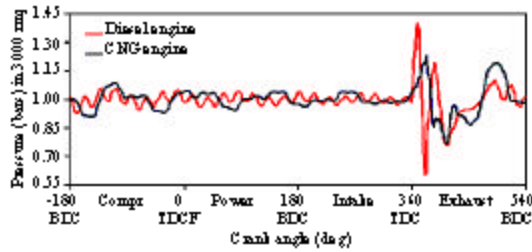

Fig. 8: CNG engine and diesel engine intake port static pressure in 3000 rpm

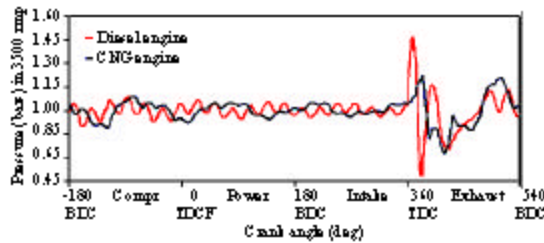

Fig. 9: CNG engine and diesel engine intake port static pressure in 3500 rpm

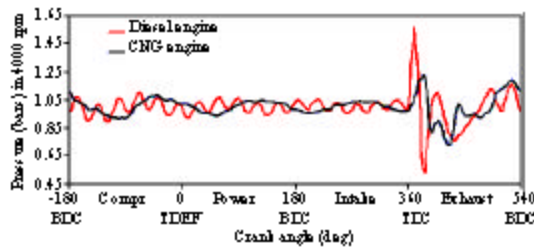

Fig. 10: CNG engine and diesel engine intake port static pressure in 4000 rpm

Figure 4-10 show the intake port static pressure profile versus crank angle profile in 1000-4000 rpm engine speeds of diesel engine and CNG engine. In this engine, speed for both of the CNG engine and diesel engine, nominal static pressure in the intake port is most extreme then in the compression stroke compare with power stroke and exhaust stroke. In the intake stroke is started from static pressure when the intake valve is start opened. In the intake valve is opened the static pressure is increase extremely because in the stroke the cylinder is needed suction air into the engine cylinder to mixture with fuel for engine combustion to product the power. In the intake valve closed processing until intake valve is closed the pressure static is very low because in this process the gas flow in the intake manifold is crass with back static pressure from intake valve closed. Then the static pressure is become lower and lower in compression stroke, power stroke and in the exhaust stroke is the lowest.

In the intake stroke of CNG engine, the intake port highest static pressure is 1.172 bar and declared in 4000 rpm engine speed and shown in Fig. 10, because in this engine speed the combustion is excellent dramatically so need most of air to combustion process. The minimum static pressure is 1.078 bar and declared in 1000 rpm engine speed and shown in Fig. 4. In the 1000 rpm engine speed investigation, the combustion and the intake valve lift and intake valve close moving is most slowly so the air flow back static pressure from the intake valve closing is lowest than the other.

In the intake stroke of diesel engine, the intake port highest static pressure is 1.335 bar and declared in 4000 rpm engine speed and shown in Fig. 10, because in this engine speed the combustion is excellent dramatically, so need most of intake air to combustion process. The minimum static pressure is 1.134 bar and declared in 1000 rpm engine speed and shown in Fig. 4, in this engine speed investigation the combustion and the intake valve lift and intake valve close moving is most slowly so the air flow back static pressure from the intake valve closing is lowest than the other engine.

CONCLUSION

The gas flow intake static pressure in intake port versus crank angle and engine speed data can be used to obtain quantitative information to predict the characteristics of the intake static pressure were needed on the progress of CNG engine combustion performance effect compare with base diesel engine. The performance results are shown that the static pressure versus crank angle of CNG engine is lower than base diesel engine and the highest intake port static pressure is in 4000 rpm both for CNG engine and diesel engine. The maximum and minimum pressure for inlet and outlet in intake port for CNG engine is lower than diesel engine. The average total pressure inlet and outlet in intake port of CNG engine model and developed is higher than the diesel engine, so the using of CNG fuel for engine will be increase the intake pressure at intake port of the engine. The model performance is higher than the other, because in model the ambient effect is zero, but the real have nominal. The increasing pressure in intake port is caused by the development of gas fuel sequential injector in the intake manifold of sequential injection CNG engine, where in the diesel engine is using direct injection, other that the combustion of diesel engine is quickly with the injection start but the CNG engine combustion is lately because the injection duration of sequential injection CNG fuel is more long time compare with direct injection diesel fuel.

REFERENCES

- Challen, B. and R. Baranescu, 2003. Diesel Engine Reference Book (Elsevier).
- Czerwinski, J., P. Comte and Y. Zimmerli, 2003. Investigations of the gas injection system on a HD CNG-Engine. SAE Paper. 2003-01-0625.
- Czerwinski, J., P. Comte, W. Janach and P. Zuber, 1999. Sequential multipoint trans-valve-injection for natural gas engines. SAE Paper. 1999-01-0565.
- Gamma Technologies, 2004. GT-power User's Manual Version 6.1. Gamma Technologies Inc.
- Hoekstra, R.L., K. Collier, N. Mulligan and L. Chew, 1995. Experimental study of a clean burning vehicle fuel. *Int. J. Hydrogen Energy*, 20 (9): 731-745.
- Hollnagel, C., J.A.M. Neto, M.E. Di Nardi, C. Wunderlich, W. Muraro, C. Miletovic and F. Bisetto, 2001. Application of the natural gas engines Mercedes-Benz in moving stage for the carnival 2001 in Salvador city. SAE Paper. 2001-01-3824.
- Hollnagel, C., L.H. Borges and W. Muraro, 1999. Combustion Development of the Mercedes-Benz MY1999 CNG-Engine M366LAG. SAE Paper. 1999-01-3519.
- Kawabata, Y. and D. Mori, 2004. Combustion diagnostics and improvement of a prechamber lean-burn natural gas engine. SAE Paper. 2004-01-0979.
- Narayanaswamy, K. and C.J. Rutland, 2004. Cycle Simulation Diesel HCCI Modelling Studies and Control. SAE Paper. 2004-01-2997.
- Parvate-Patil, G.B., H. Hong and B. Gordon, 2003. An Assessment of Intake and Exhaust Philosophies for Variable Valve Timing. SAE Paper. 2003-32-0078.
- Parvate-Patil, G.B., H. Hong and B. Gordon, 2004. Analysis of variable valve timing events and their effects on single-cylinder diesel engine. SAE Paper. 2004-01-2965.
- Poulton, M.L. 1994. Alternative Fuels for Road Vehicles Computational Mechanics Publication.
- Riegler, U.G. and M. Bargende, 2002. Direct coupled 1D/3D-CFD-computation (GT-Power/Star-CD) of the flow in the switch-over intake system of an 8-cylinder SI engine with external exhaust gas recirculation. SAE Paper. 2002-01-0901.
- Suga, T., T. Muraishi, T. Brachmann and F. Yatabe, 2003. Potential of a natural gas vehicle as EEV. SAE Paper. 2000-01-1863.
- Xu, B. Y., F.Y. Liang, S.L. Cai and Y.L. Qi, 2005. Numerical Analysis of Fuel Injection In Intake Manifold And Intake Process of A MPI Natural Gas Engine. *Int. J. Automotive Technol.*, 6 (6): 579-584.
- Zastavniouk, O., 1997. Study of Mixing Phenomena in a Dual Fuel Diesel Engine Air Intake Manifold, MSc Thesis, University of Alberta.