

## Volume Determination with Waves Scattered from Surfaces

<sup>1</sup>Ymer Halimi, <sup>1</sup>Albert Januzaj, <sup>1</sup>Besim Xhafa and <sup>2</sup>Ismet Ibishi

<sup>1</sup>Faculty of Medicine, University of Prishtina, Kosova

<sup>2</sup>Faculty of Applied Technical Sciences, University of Prishtina, Kosova

**Abstract:** Surfaces from which the ultrasound is reflected, very often are not flat. Therefore, in these surfaces there exist scatterers of ultrasound waves that prevent measurements. Nevertheless, on the other hand, scattered waves can be successfully used for measurements. For instance, obtained results from measurements with scattered waves, show that it is possible to make a comparison between the unknown volume with a given volume, taking the sum of the product of the squares of amplitudes of impulses of pressure or the sum of intensities and time increments of given volumes. The method of echo-systems of oriented waves is more complicated than the method with non-oriented waves (scattered waves). Therefore, here it will be shown the possibility of the use of the systems with non-oriented waves, in order to determine the volumes of systems with a regular or at least approximately regular geometry.

**Key words:** Scattering, interference, surface density, ultrasound probe, ultrasound impulse, volume, square of the impulses of the pressure

### INTRODUCTION

**The source of spherical waves:** The oscillation of a spherical surface is a wave source, which can be represented by the velocity function  $U(\vartheta)e^{-i\omega t}$ , where the amplitude of velocity  $U(\vartheta)$  is a function of the solid angle expressed by the terms of the Legendre's function (Morse and Ingard, 1968):

$$U(\vartheta) = \sum_{m=0}^{\infty} U_m P_m(\cos \vartheta) \quad (1)$$

where,  $U_m$  is:

$$U_m = (m + \frac{1}{2}) \int_0^{\pi} U(\vartheta) \times P_m(\cos \vartheta) \times \sin \vartheta d\vartheta \quad (2)$$

On the other hand, the pressure is expressed in the form:

$$p = \sum_{m=0}^{\infty} A_m \times P_m(\cos \vartheta) \times h_m(kr) \times e^{-i\omega t} \quad (3)$$

Radial velocity of the spherical wave surface in the distance  $a$  is:

$$u_a = \frac{1}{\rho c} \sum_{m=0}^{\infty} A_m \times B_m \times P_m(\cos \vartheta) \times e^{-i(\delta_m + \omega t)} \quad (4)$$

Where:

$$\frac{dh_m(\xi)}{d\xi} = iB_m(\xi) \times e^{i\delta_m(\xi)}, \quad \xi = ka = 2a\pi/\lambda \quad (5)$$

Using some properties of spherical Hankel's functions ( $h_m$ ) of the  $m$ th order (Abramowitz and Stegun, 1972), for the values  $ka \ll m + 1/2$  (very small), we obtain (Morse and Ingard, 1968):

$$B_0 \cong (\frac{1}{ka})^2; \quad \delta_0 \cong (ka)^3 / 3 \quad (6)$$

respectively, for  $m > 0$ , it is:

$$B_m \cong \frac{1 \times 2 \times 3 \times 5 \dots (2m-1) \times (m+1)}{(ka)^{m+2}}$$

and

$$\delta_m \cong \frac{-m(ka)^{2m+1}}{1^2 \times 3^2 \times 5^2 \dots (2m-1)^2 \times (2m+1) \times (m+1)} \quad (7)$$

Whereas, when  $ka \gg m + 1/2$ , we have:

$$B_m \cong 1/ka$$

and

$$\delta_m \cong ka - \pi(m+1)/2$$

The radial velocity in the distance  $r = a$  is equal with the velocity of the surface of the sphere.

Equalizing the coefficients of the same order, term by term, we obtain the equation for the coefficient  $A_m$ , expressed by the function  $U_m$  (Morse and Ingard, 1968):

$$A_m = \frac{\rho c U_m}{B_m} \times e^{-i\delta_m} \quad (8)$$

Pressure and the radial velocity for large distance from the sphere are:

$$p = \rho \times c \times u_r; U_r \cong \frac{U_0 \times a}{r} \times e^{ik(r-ct)} \psi(\vartheta) \quad (9)$$

where,  $\psi(\vartheta)$  is:

$$\psi(\vartheta) = \frac{1}{ka} \sum_{m=0}^{\infty} \frac{U_m}{U_0 B_m} \times P_m(\cos \vartheta) \times e^{-i[\delta_m + \pi(m+1)/2]} \quad (10)$$

$U_0$  = The mean velocity of the spherical surface of the wave

Velocity in the vicinity of the sphere which oscillates, is not in phase with the pressure and is not completely radial, but, going further away from the sphere, it becomes more radial and establishes a phase with the pressure. When the product  $kr$  is very large, then the wave intensity (I) and the total power (II) given from the source, in a point with coordinates  $(r, \vartheta)$ , is:

$$\Pi = \int_0^\pi d\varphi \int_0^\pi r^2 I_r \sin \vartheta d\vartheta = \frac{\rho \times c^3}{4\pi \nu} \sum_{m=0}^{\infty} \frac{U_m^2}{(2m+1)B_m^2} \quad (11)$$

**Theory of scattering in spherical bodies:** Scattering is a phenomenon of wave propagations and most of theories of scattering of different waves are similar, except in some relevant terms in certain wave equations.

Scattering in tissues is not possible to be investigated in an exact way, since the acoustic properties of tissues with dimensions smaller than the ultrasound wavelength are not known sufficiently. Therefore, only the usual tissue models are used and investigated.

The theory of scattering in spherical and cylindrical objects has been developed by Morse and Ingard (1968). There exist also other solutions for other types of scatterers, but for biology and medicine, the most important are spherical and cylindrical scatterers.

In most cases, the theory of wave scattering is realized with plane waves, whereas for ultrasound the most useful is pulsive echoscopy. In this research, we have performed the experiment with pulsive ultrasound waves. The multiple scattering is neglected, taking into account the Born's approximation.

When the obstacle is much larger than the wavelength, a shadow with defined borders is created (known from geometrical optics). Therefore, in the following, we will deal with scatterers with dimensions much smaller than the wavelength. In this study, the whole scattered wave, as well as the angular scattering of the wave is discussed.

The plane wave propagating through a medium without obstacles is represented by the equation:

$$p = A e^{ik(x-ct)} = A e^{ik(r \cos \vartheta - ct)} = A \sum_{m=0}^{\infty} (2m+1) \times i^m P_m(\cos \vartheta) j_m(kr) e^{-i\omega t} \quad (12)$$

Where:

$P_m$  = Legendre' function

$j_m$  = Bessel's function

$A = \sqrt{\rho c I}$  = The wave amplitude (Morse and Ingard, 1968)

The wave is propagated in the positive direction of the x-axis. This wave meets the sphere with radius  $a$  with the center at the origin of the polar coordinate system, where the scattering occurs. The equation for the scattered wave in the sphere is:

$$p_s = -A \sum_{m=0}^{\infty} \left( (2m+1) \times i^{m+1} \times e^{-i\delta_m} \times \sin \delta_m \right) \times \left( P_m(\cos \vartheta) \times [j_m(kr) + i n_m(kr)] \times e^{-i\omega t} \right) \quad (13)$$

whereas, the phase is given by the equation:

$$\delta_m = ka = \frac{2a\pi}{\lambda} - \frac{m+1}{2}; ka \gg \frac{m+1}{2} \quad (14)$$

and the intensity of the wave with frequency  $\nu$  is:

$$I_s = \frac{a^2 I}{r^2} \times \frac{1}{k^2 a^2} \sum_{m,n}^{\infty} \left( (2m+1)(2n+1) \sin \delta_m \sin \delta_n \right) \times \left( \cos(\delta_m - \delta_n) P_m(\cos \vartheta) P_n(\cos \vartheta) \right) \quad (15)$$

$$I_s = \frac{16\pi^4 \nu^4 a^6 I}{9c^4 r^2} (1 - 3\cos \vartheta)^2; ka \ll 1$$

$$I_s = I \left[ \frac{a^2}{4r^2} + \frac{1}{4r^2} \cot^2 \left( \frac{\vartheta}{2} \right) \times J_1^2(ka \times \sin \vartheta) \right]; ka \gg 1 \quad (16)$$

The energy of the scattered wave is expressed by the equation:

$$\Pi_s = 2\pi a^2 I \frac{2}{k^2 a^2} \sum_{m=0}^{\infty} (2m+1) \times \sin \delta_m$$

$$\lambda \gg 2\pi a = \frac{256\pi^5 a^6}{9\lambda^4} \quad (17)$$

$$\lambda \ll 2\pi a = 2\pi a^2 I \quad (18)$$

The orientation of the direction of the scattered waves is increased with the increase of frequency.

### MATERIALS AND METHODS

Let a model of a sphere and a parallelepiped are given, which change their volume with a radial pulsation (Fig. 1).

The question is: is it possible that this change in volume can be measured and controlled by the method of the non-oriented pulsive echoscopy. The concept of the solution of this problem is given:

**Ultrasound probe:** Piezoelectric probe is placed in the model (in this case, sphere and parallelepiped), in a certain distance. Experimental results are related to the distance of the probe from the walls of the model. The anisotropy of the ultrasound source is shown in Fig. 2, where we see that the intensity of the ultrasound is decreasing in the angular zones 0/30° and 150/180°.

Since, the probe is insensitive for waves arriving from these zones, then a special algorithm is used to evaluate the echoes of these zones, since these data complete the recording of the echo-system (Breyer, 1982).

**Ultrasound impulse:** Ultrasound probe emits an impulse of the shape given in Fig. 3a. The duration of this impulse is 1.5 μs. The speed of propagation is  $c = 1500 \text{ m sec}^{-1}$  (for liquids). The equation of the impulse of the pressure is:

$$p = p_0 (\lambda^2 t^2 / 2) \times e^{-\lambda t} \sin \omega t \quad (19)$$

- $\lambda$  = The attenuation coefficient of the order  $3 \cdot 10^6$
- $\nu$  = The frequency ( $\nu = \omega/2\pi$ ), taken 4 MHz
- $p_0$  = The initial amplitude of the pulse which must be small enough, in order that the linearity of the material is maintained. In practice, this is possible and is most widely used in medical practices

It is necessary that the composition of frequencies of the ultrasound impulse be determined (Husnia, 1982). This can be immediately performed using the Fourier transformations (Fast Fourier Transform, FFT) (Yang *et al.*, 2005) which is based in two conditions:

- Function must be discussed in a certain domain
- Values must be discussed only for a certain number of separate points, for a time interval  $\Delta t$

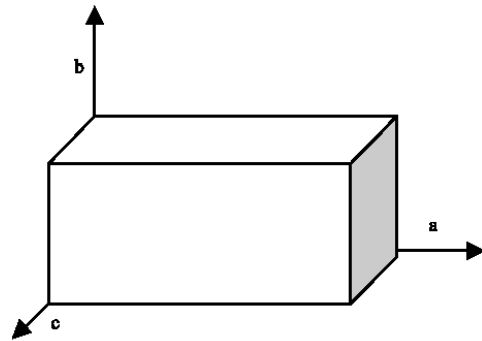

Fig. 1: A simplified model of structure with tissue walls

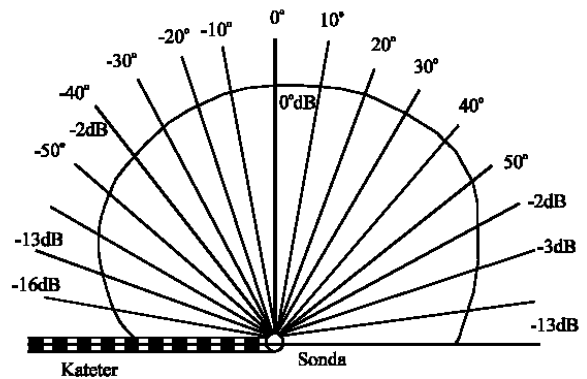

Fig. 2: Diagram of the intensity distribution of real ultrasound source

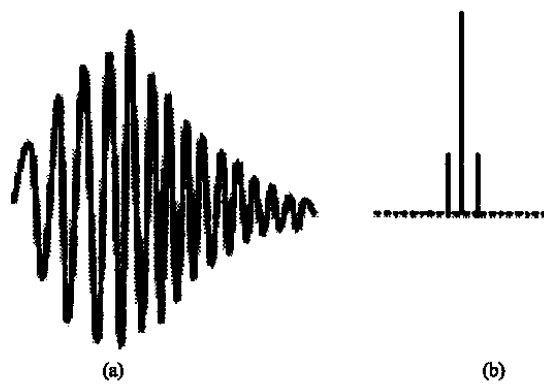

Fig. 3: a) The shape of the ultrasound impulse, b) Frequency analysis of the pulse

### RESULTS AND DISCUSSION

Scattered waves interfere in the probe, whereas the time process is given in graphs of Fig. 4a-c. The abscissa represents the time expressed in ms and the ordinate represents the square of the impulses of the pressure ( $p$ ) of the ultrasound.

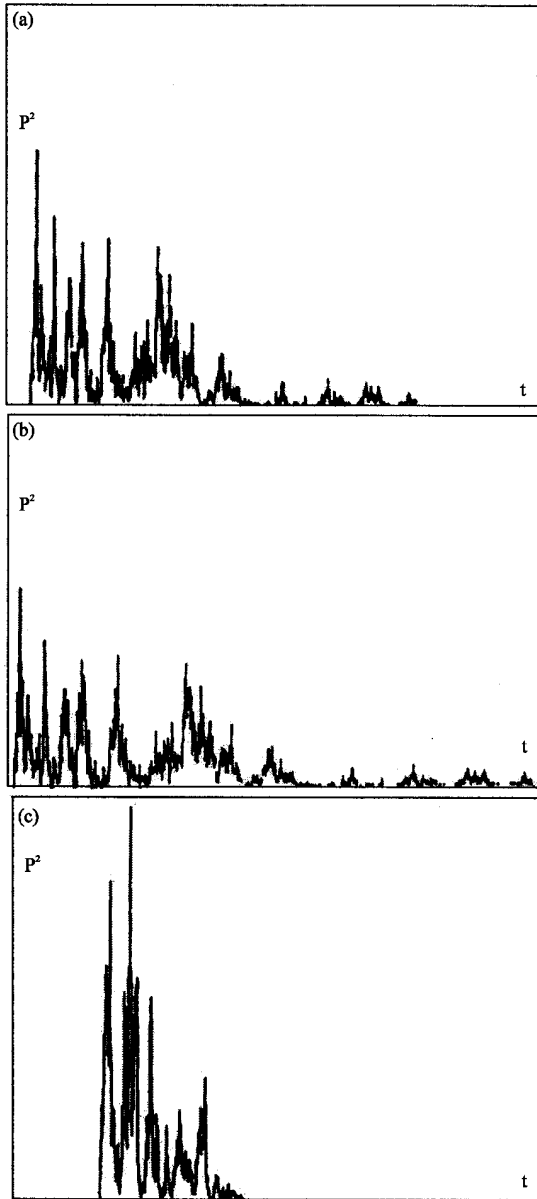

Fig. 4: Interference of ultrasound waves in the probe: a)  $P = 1.5$  cm,  $a = 11$  cm,  $\sigma = 10$  cm<sup>2</sup>, b)  $P = 1$  cm,  $a = 12$  cm,  $\sigma = 10$  cm<sup>2</sup> and c)  $P = 3$  cm,  $a = 12$  cm,  $\sigma = 10$  cm<sup>2</sup>

During the analysis, the surface density ( $\sigma$ ) is kept constant, whereas the distance of the probe from the walls of the parallelepiped has been changed. Increasing the volume for the unchanged position of the probe, the time duration of the signal is increased, whereas the shapes of the specter remained very similar.

If for the same volume, the probe is moved away from the walls of the parallelepiped, starting time of the specter

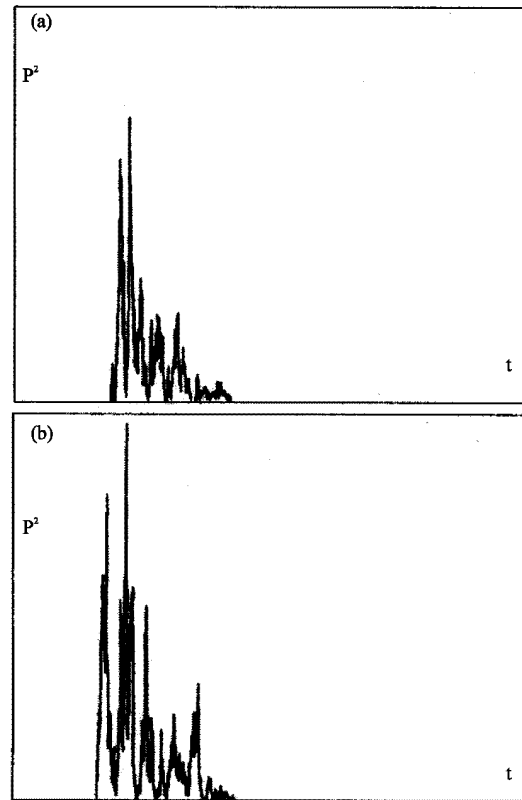

Fig. 5: Interference of ultrasound waves in the probe: a)  $P = 2.5$  cm,  $a = 6$  cm,  $\sigma = 18$  cm<sup>2</sup> and b)  $P = 2$  cm,  $a = 6$  cm,  $\sigma = 16$  cm<sup>2</sup>

is displaced on the right and its duration became shorter (Fig. 4c). In Fig. 5 is shown the interference in the probe when the surface density  $\sigma$  is increased. It can be observed that the amplitude of the signal has been increased in comparison with the amplitudes of the previous configurations shown in Fig. 4a-c.

In the numerical analysis performed, we have obtained the total number of the squares of amplitudes of the pressure, for the impulses recorded in the probe, for a certain time interval. These quantities are sensitive on volume change. We have determined the parameters that affect the responses: the position of the probe and the surface density of scatterers. Results are represented by numerical values and curves. All impulses that are received from the nearest scatterers have greater intensities than those from the farthest scatterers. For impulses that are received at the same time, their mean value is taken.

In Fig. 6, curves for four different cases of the position of the probe inside the parallelepiped are shown. Experimental results are processed with applicative programmes for statistical processing.

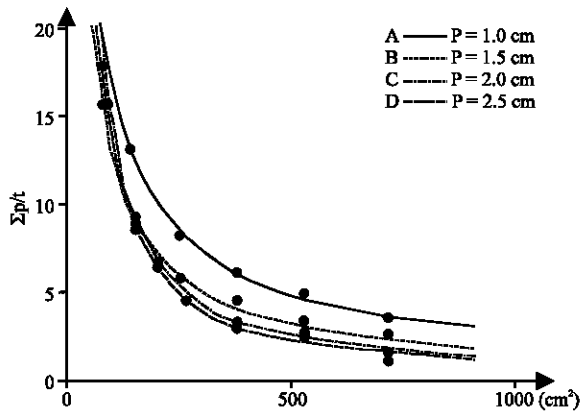

Fig. 6: Dependence of  $\Sigma p/t$  on volume for different positions of the probe inside the sphere

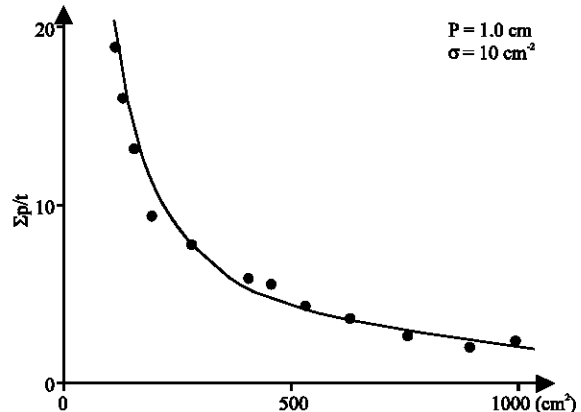

Fig. 8: Dependence of  $\Sigma p/t$  on volume and surface density for an optimal position of the probe

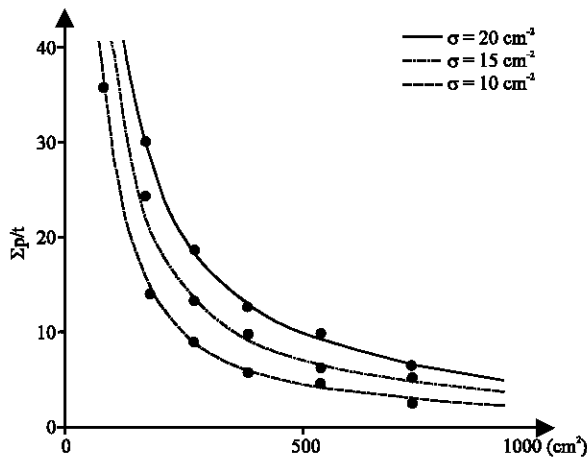

Fig. 7: Dependence of  $\Sigma p/t$  on volume for different surface densities

Correlation coefficients in obtained curves, are best fitted in the curve A. This curve corresponds to the position of the probe in the distance 1 cm from the walls of the parallelepiped.

This result shows that one must be careful where the probe should be placed, since its sensitivity is significant in the position 1.5 cm from the walls and this is the distance usually used in systems. For greater distances this sensitivity is irrelevant. In this analysis it is observed that numerical channel that belongs to the first recorded impulse, depends on the position of the probe.

For finding the best position of the probe, usually the calibrating graph is used. Another important parameter is the change of the surface density  $\sigma$  and in Fig. 7 results for three cases of surface density are shown. Curves are

very similar and have almost the same shape and are nearly equidistant. Therefore, whichever surface density is taken, the error is not significant.

Taking into account these two parameters, we find the relation between processes of  $(p^2/t)$ .

In Fig. 8, it is shown the dependence of the sum of the squares of impulses on the volume of parallelepiped with density  $\sigma = 10 \text{ cm}^2$  and for a distance of the probe from the walls of 1 cm. The curve shows a hyperbolic dependence of the time average of the squares of amplitudes of pressure on the volume of the parallelepiped. Therefore, this quantity can be used as a measure for changes in volume of the parallelepiped.

### CONCLUSION

The results that are obtained quantitatively describe energetical and temporal echo-system response in relation to the volume of a solid. The results are applicable in practice for approximately fixed geometrical conditions.

### REFERENCES

Abramowitz, M. and I. Stegun, 1972. Handbook of Mathematical Functions. Dover Publications, New York.  
 Breyer, B., 1982. Medicinski Dijagnosticki Ultrazvuk. 1st Edn. Skolska Knjiga, Zagreb.  
 Husnia, K., 1982. Osnovi Tehnicke Akustike. 2nd Edn. Nucna Kniga, Beograd.  
 Morse, P.H. and K. Ingard, 1968. Theoretical Acoustics. 1st Edn. McGraw-Hill, New York. ISBN: 86-42860.  
 Yang, W., W. Cao, T. Chung and J. Morris, 2005. Applied Numerical Methods Using MATLAB. John Wiley and Sons, New Jersey.