

Version of Switched Reluctance Generator Rotor at a Fixed Configuration of Stator

N. Grebennikov and A. Kireev
Closed Joint-Stock Company Scientific-Technical Center,
346428 Novochoerkass City, Krivoshlykovast, Rostov Region, Russia

Abstract: The investigation of the influence of the number of phases of Switched Reluctance Generator (SRG) to the pulse of electromagnetic torque was carried out. The computer model was created. The amplitude of torque ripples reduces to 6 times with increasing of the ripple frequency to 5 times that is more acceptable in terms of requirements.

Key words: Switched reluctance machines overlap factor, number of phases, computer model, pulse, torque

INTRODUCTION

Switched Reluctance Machines (SRM), designed as a high efficiency type of electromechanical energy converter (Voron *et al.*, 2009) can be applied on vehicles including railway rolling stocks.

Electrical machines used on vehicles operate in severe conditions. During operation they are affected by significant dynamic forces resulting from vibration and shock particularly at high running speeds. It can cause to various failures: wires and winding connection disruption, cracking and insulating materials damage. For this reason when choosing electrical machines design there is a tendency to use simple and reliable technical solutions.

From this point of view, the main advantage of SRM is the design simplicity. The rotor is passive without winding and the stator is equipped with winding consisting of centered type coils. In comparison with other types of electrical machines, SRM is more sophisticated has less specific consumption of cooper and insulating materials. In case of SRM application on the vehicles, it will allow to improve the reliability of energy supply system to achieve better energy and weight-size parameters to reduce the cost and operation expenses. The disadvantages of SRM are considerable electromagnetic torque ripple and higher noise level.

VERSIONS OF SWITCHED RELUCTANCE GENERATOR

Consider the possibility to reduce the torque ripple on the example of Switched Reluctance Generator (SRG) having classical configuration 18/12 (18 teeth at the stator and 12 at the rotor). The 18 coils located at the stator are divided into three phases and the angle between coils axes is 60°.

In Kuznetsov and Kuz'michev (2003), it is said that if the terms of SRM should ensure the high stability of rotation frequency and low torque ripple, the number of phases should be chosen as maximum possible. Increasing the number of SRM phases can be obtained by changing the number of teeth at the rotor while maintaining the same stator with 18 teeth, it is specified by economic considerations.

Consider the possible variants of SRG configuration, with stator having 18 teeth and coils disposed at each tooth, depending on number of teeth at the rotor (the number of teeth at the rotor is #18):

- С The 18/18; a single phase machine with strong torque
- С The 18/9; two-phase machine which torque ripple is higher than three-phase machine obtains (Kuznetsov and Kuz'michev, 2003) with account of the fact that this ripple is conceptually impossible to eliminate (Krasovskiy and Bychkov, 2001)
- С The 18/12; three-phase machine, the number of stator teeth was increased three fold compared to basic three-phase machine configuration 6/4. It allows to reduce the noise level (Kuznetsov and Kuz'michev, 2003)
- С The 18/16; nine-phase machine with alternating polarity of adjacent windings and strong mutual inductance of adjacent phases. Note that the number of Power Semiconductor Devices (PSD) in the converter is increased by three times compared to the converter of three-phase machine.

Based on analysis of SRG performance with different numbers of rotor teeth, six-phase machine with 18/15 configuration is proposed for application. The cost of the converter for this kind machine will be much lower than for nine-phase machine: the design of converter is known

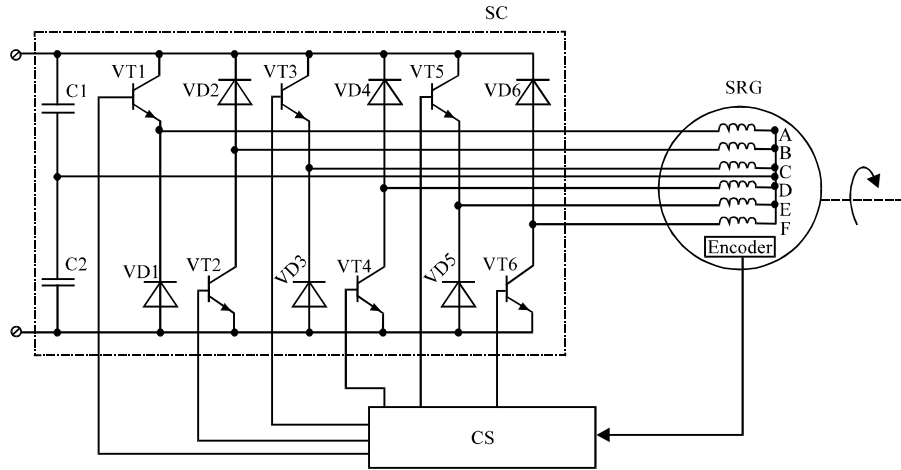

Fig. 1: Scheme of six-phase SRG and supply converter (SC: Static Converter; CS: Control System; Encoder-rotor position sensor)

Table 1: Versions of SRM configuration

Teeth at stator	Teeth at rotor	No. of phases	No. of coils in the single phase	No. of PSD	Absolute overlapping factor (D_A)	Effective overlapping factor (D_E)
18	18	1	18	4	0.5	-
18	9	2	9	8	1.0	0.5
18	12	3	6	12	1.5	1.0
18	15	6	3	24 (12)	3.0	2.5
18	16	9	2	36	4.5	4.0

for machine's supply (Fig. 1) having the same numbers of PSD as well as for three-phase machine (Miller, 1993).

The main condition for elimination of electromagnetic torque ripple in SRM is partial overlapping of machine's operation areas by adjacent phases. To estimate the possible overlapping of these areas, two factors are used (Krasovskiy and Bychkov, 2001; Miller, 1993):

Absolute overlapping factor:

$$\rho_A = \frac{m}{2}$$

Where:

m = Number of SRM phases

Effective overlapping factor:

$$\rho_E = \frac{N_R}{2(N_S - N_R)}$$

Where:

N_R = No. of rotor teeth

N_S = No. of stator teeth

From the formula analysis given earlier, it follows that the increase of absolute overlapping factor is possible under condition of increasing the number of phases and the increase of effective overlapping factor is provided

with increasing the number of rotor teeth. Versions of SRM configuration and the values of overlapping factors are given in Table 1.

Table 1 shows that the minimal torque ripples take place when maximum possible value of phase number but it increases significantly the quantity of PSD and the cost of converter becomes the highest. From the other hand, the lowest cost of the converter is achieved at the lowest possible value of phase number (a single phase) but this variant is not rational for vibroacoustic indicators. The low torque ripple of SRG and the cost of its control system are mutually conflicting criteria, so the proposed variant of 18/15 configuration is optimal (Grebennikov and Petrushin, 2012).

COMPUTER SIMULATION

To investigate different operation modes of SRG and to develop the optimal control of phase switching, the computer simulator of SRG electrical part has been developed in software package Matlab/Simulink (Fig. 2) with account of mutual phase inductance.

The management of keys VT1-VT6 switching is performed by unit Upravlenie, based on received signals: ω rad sec⁻¹ angular frequency of rotor rotation, pos: angular rotor position relative to stator, I(A): current value in SRG windings.

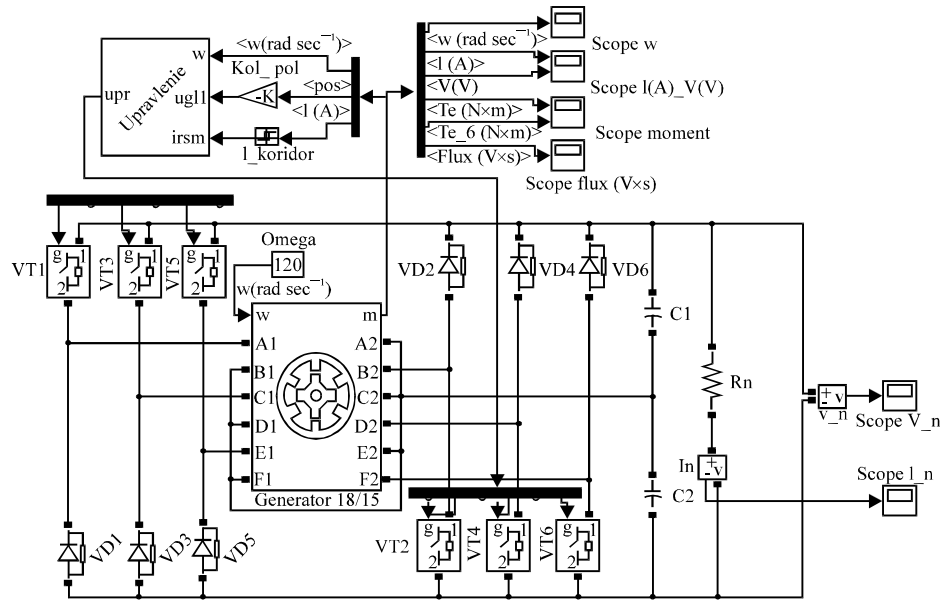

Fig. 2: Computer model of six-phase SRG 18/15 configuration

Table 2: Comparison of electromagnetic torques of SRG different configuration

SRG configuration	No. of SRG phase	Rotor rotation frequency T_p , (rad sec ⁻¹)	Torque ripple frequency (Hz)	Minimal torque value (M_{MIN} , oe)	Ripple amplitude (M_A , oe)	$M_A/ M_{MIN} $
18/12	3	100	573	-1.00	0.469	0.469
18/15	6	100	2860	-0.57	0.081	0.141

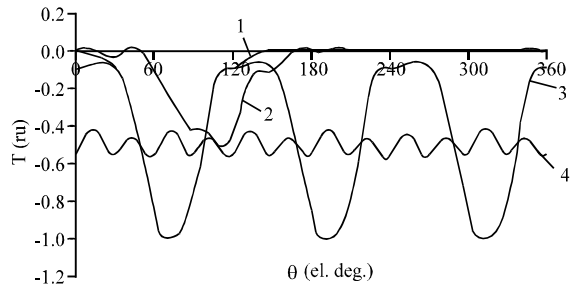

Fig. 3: Dependence of SRG electromagnetic torques (1-torque of single phase of SRG 18/12, 2-torque of single phase of SRG 18/15, 3-total torque of SRG 18/12, 4-total torque of SRG 18/15)

The initial supply impulse goes to generator from pre-charged capacitor N. Units scope w, scope I(A)_V(V), scope moment, scope flux (V*s), scope V_n and scope I_n are designed for oscillograms recording of the following: angular rotation frequency of current and voltage in stator windings of generator, electromagnetic torque, flux linkage, load voltage and load current.

As a result of simulation it was obtained current, voltage in SRG windings and electromagnetic torque

dependences on angular rotor position for three-phase and six-phase configuration of SRG. Figure 3 presents the diagrams of phase torques (curves 1 and 2) and total electromagnetic torques (curves 3 and 4) in relative units.

The comparison of electromagnetic torques is given in Table 2 which demonstrates that the frequency of electromagnetic torque ripples at six-phase SRG configuration increases by about five times and amplitude of torque ripples decreases approximately by six times.

CONCLUSION

Replacing the rotor having 12 teeth with the rotor having 15 teeth while maintaining the same stator and power converter allows us to reduce electromagnetic torque ripple approximately by 6 times.

ACKNOWLEDGEMENT

The presented research has been developed with support of Russian Ministry of Education, grant RFMEFI57614X0036.

REFERENCES

- Grebennikov, N.V. and A.D. Petrushin, 2012. Reactive switched electrical machine with rotation symmetry. Russian Patent 2450410, Rostov-na-Donu, Russian Federation Publication, Russia. <http://russianpatents.com/patent/245/2450410.html>.
- Krasovskiy, A.B. and M.G. Bychkov, 2001. Investigation of torque ripple in the switched reluctance electric drive. *Electricity*, 10: 33-43.
- Kuznetsov, V.A. and V.A. Kuz'michev, 2003. Switched Reluctance Motor. MEI Publisher, Lancaster, South Carolina, pp: 68.
- Miller, T.G.E., 1993. Switched Reluctance Motors and Their Control. Magna Physics Publishing, Oxford, ISBN: 9780198593874, Pages: 200.
- Voron, O.A., N.V. Grebennikov, A.A. Zarifian and A.D. Petrushin, 2009. Undercar switched reluctance generator. *Bull. Russian Res. Design Inst. Electric.*, 1: 132-143.