

Transformation of Signals in the Optic Systems of Differential-Type Fiber-Optic Transducers

T.I. Murashkina, E.A. Badeeva, O.V. Yurova, M.M. Savochkina and A.V. Motin
 Penza State University, 40 Krasnya Str., 440026 Penza, Russia

Abstract: The study offers to perform a differential transformation of optic signals directly in the measuring zone by developing the conic structure of luminous flux and dividing it into two fluxes (each of which is processed in a separate measuring channel) to improve metrological characteristics of fiber-optic sensors based on changing the intensity of luminous flux under the influence of measured physical quantity. The independence of two measuring channels and reduction of linear error are provided in a constructive way. The article gives the examples of structural implementation of differential fiber-optic sensors.

Key words: Fiber-optic transducer, optical signal, differential transformation, light flux, measurement channel, optical modulating element, linearization, sensitivity

INTRODUCTION

To reduce the superfluous errors in the sensors of physical quantities, which are influenced by various destabilizing factors, technologies use signal transformation differential circuits (Badeeva *et al.*, 2004; Kolominets *et al.*, 2007). Moreover, differential transformation of signals allows linearizing the transformation function of sensors and increase the signal transformation sensitivity (Badeeva *et al.*, 2008). The latter advantage is especially important in Fiber-Optic Sensors (FOS) where optical systems involve transformations of low-power optical signals. The task of optical signal differential transformation in FO sensors was solved directly in the zone of measured information perception, i.e., at the location of Fiber-Optic Transducers (FOT) (Murashkina *et al.*, 2008; Murashkina and Pivkin, 2005).

To implement the differential transformation of optic signals, the light flux Φ_0 of an Emitting Source (ES) should be divided into two equal fluxes $\Phi_1(X)$ and $\Phi_2(X)$; each of them is transformed further under a measured physical quantity X in the first or second FOS measurement channels (Fig. 1) (Badeeva *et al.*, 2008).

At the outlet of the Input Optic Fiber (IOF) it is necessary to form such light flux structure (Fig. 2) which can split it in two light fluxes (e.g., along the X axis) by Optical Modulating Elements (OME) and certain lay-outs of optic fibers at the ends of the fiber-optic cable. Each of them will be transformed further in the sensor's first or second measurement (or in the Measurement and Compensation) channels (MC).

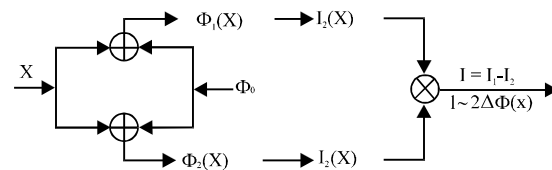

Fig. 1: FOS measurement channels

For instance, in attenuator-type micro displacement FOTs, the light flux is formed as a beam of parallel rays along the guiding lines of a hollow truncated cone, whose walls' thickness is equal to the width of the beam and is $0.5Z_{max} \dots Z_{max}$; the radius of the small base of the cone is Z_{max} , the radius of the greater base is $(X_0 \text{tg} \Theta_{NA} + Z_{max})$, where Θ_{NA} is the aperture angle of the optical fiber, Z_{max} is the maximal value of a micro displacement, $(90 - \Theta_{NA})$ is the angle at the base of the cone, X_0 is the distance from the IOF work end to the OME moving surface ($X_0 = dc/2\text{tg} \Theta_{NA}$, where dc is the diameter of the optic fiber core). The light flux is directed to the moving OME. A beam receiver fixes the optical power of the flux modulated in the measured physical quantity function (Fig. 3a).

There are two basic ways of FOS's light flux splitting: to attach an IOF (common for both MCs) to the ES and to separate the flux into two streams by means of an Optical Modulating Element (OME) (Fig. 3a and b), to attach the IOFs of the first and second MC to one ES; the light fluxes go to the measurement zone along the IOFs and further transformations are carried out in each MC separately (Fig. 3c).

There are also some obligatory conditions: uniformly distributed light intensity in the zone of the differential

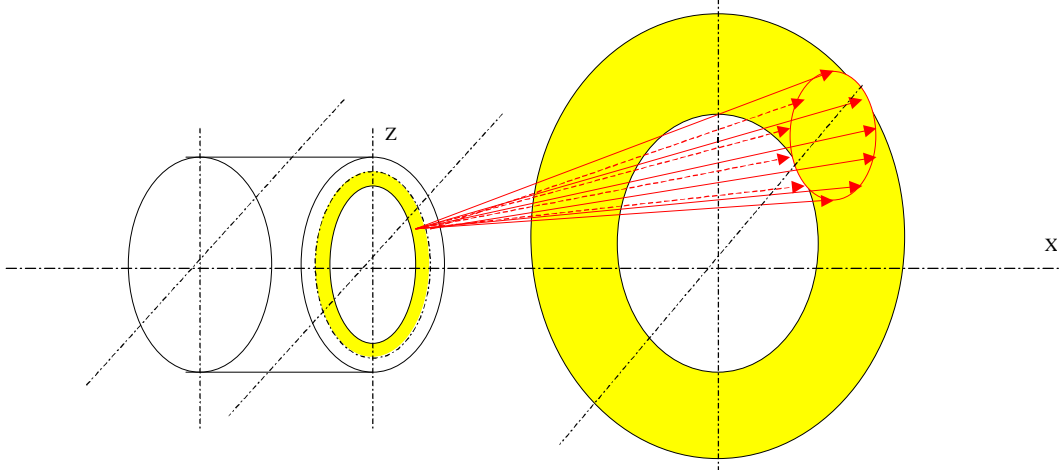

Fig. 2: Formation of an annular zone at the optical fiber outlet

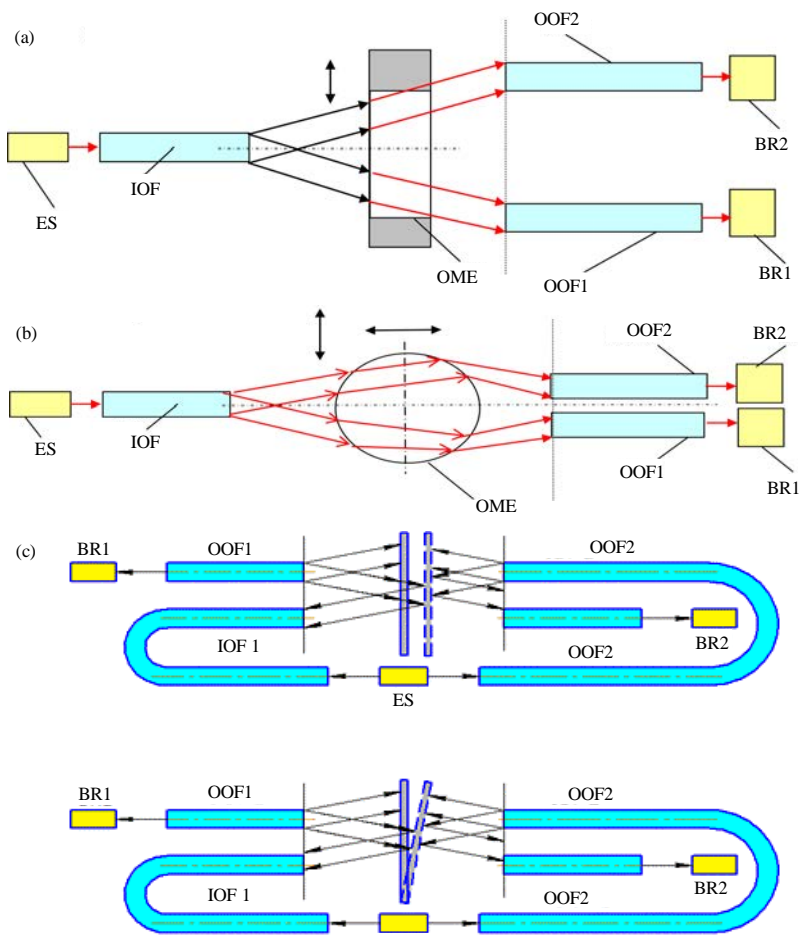

Fig. 3: Implementation of differential transformation circuit in a displacement differential FOT; a) with cutoff attenuators with a circular hole, b) with a cylindrical (or ball) lens; c) with reflecting surfaces

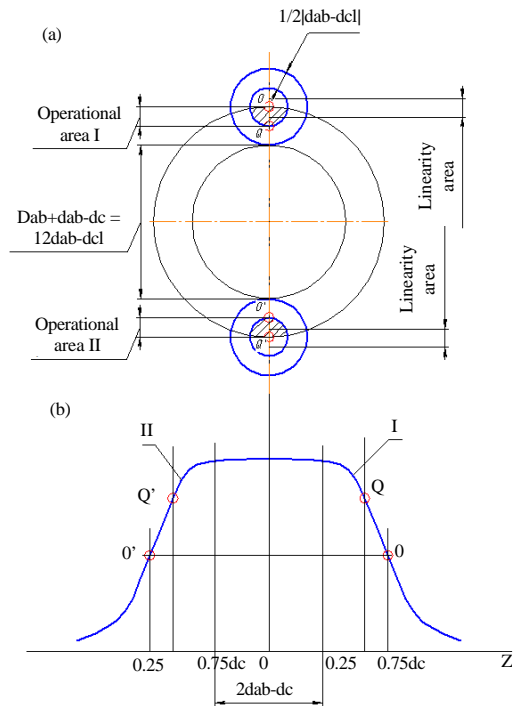

Fig. 4: a, b) Relative change of light flux intensity $\Phi_1/\Phi_0 = f(Z)$ in the area of OOF's receiving ends in the attenuator-type micro displacement FOT

OME and the Output Optic Fiber (OOF) receiving ends, the lay-out of OOFs at fiber-optic cable work ends and their position relative to the differential OME must ensure signal increase in one channel and its decrease in the other one (Fig. 4), the differential OME's structural and technological modification algorithm must ensure signal increase in one channel and its decrease in the other one (Fig. 4).

Many FOTs transform physical quantities into a linear or angular OME displacement and then to optical signal power ramping (Fig. 3). The facilities used as OMEs include surfaces (mostly mirror-like) with different reflection coefficients, radiuses of curvature (ball, cylindrical lenses), refraction coefficients and others (Murashkina *et al.*, 2008; Badeeva *et al.*, 2003; Yurova *et al.*, 2011).

Figure 4 shows the relative change of light flux's intensity for the first MC $\Phi_1/\Phi_0 = f(Z)$ (area I) and the second MC $\Phi_2/\Phi_0 = f(Z)$ (area II) within the measurement range of attenuator-type micro displacement FOTs (Fig. 3a). The function graph has non-linear parts in the initial and final intervals that is connected with a significant change of the illuminated surface area in the plane of the OOF. Linear differential transformation is carried out at the intervals OQ and $O'Q'$ if the upper and lower boundaries of the attenuator hole pass through internal cone generators.

Thus, it is possible to improve the linearity of the relation $\Phi_1/\Phi_0 = f(Z)$ and the optic signal modulation depth via clipping of transformation function non-linear intervals by varying the micro displacement FOT's design parameters:

- By changing the spacing between the optic fiber and the OEM
- By changing the OEM's design parameters (e.g., the attenuator hole radius)

An important part of differential circuit implementation is the requirement of independence of the two measurement channels. It becomes possible if the graph 'flat' line connecting the relations $\Phi_1/\Phi_0 = f(Z)$ and $\Phi_2/\Phi_0 = f(Z)$ is not less than $(2d_{OB}-dc)$. In this case, the light flux of the first MC does not get to the OOF of the second MC and the light flux of the second MC does not enter the OOF of the first MC.

Differential FO sensors can be divided into 2 types according to the type of input and output signals of the interface connecting the sensors with the external registering equipment: with an electrical and optical interface (Fig. 5).

On the first case, an FOS consists of an FOT and Optoelectronic Block (OEB) (Fig. 5a). The input and output signals of such sensor is electric. In the second case, an FOS is only an FOT, the input and output signals of which are optic.

An FOT consists of a Measurement Transducer (MT) and a Fiber-Optic Cable (FOC). An FOC has input (IOC) and Output (OOC) optic channels including one or several IOFs and OOFs. An OEB consists of an Emitting Source (ES) and Beam Receivers (BR) performing the functions of electro-optical and photoelectric transducers, respectively. For the efficient transmission of the light flux from the ES to IOF and from the OOF to the BR, there are alignment units AU1, AU2 and AU3. If the alignment units do not have movable elements for aligning, they serve as Optical Connectors (OC).

The general operating principle of a differential FOS is as follows. The optical signal Φ , the part of which Φ_0 goes to the FOC input through an alignment unit AU1. It is transmitted over IOC optical cables to the MT measurement zone where its intensity Φ_0 changes under the influence of a measured physical quantity X. One part of the light flux $\Phi_{1MT}(X)$ modulated in the function X goes to OOC1 optic fibers and the other part $\Phi_{2MT}(X)$ modulated in the function X to OOC2 optic fibers.

Through alignment units AU2 and AU3, the light fluxes are transferred to the BR1 and BR2 of the first

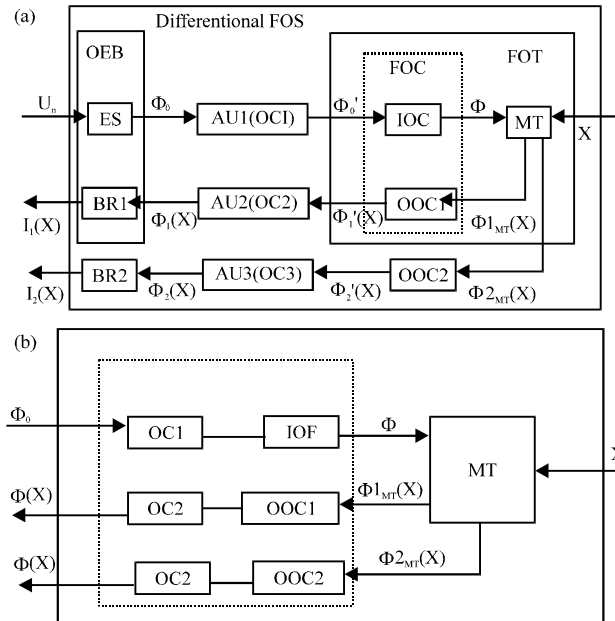

Fig. 5: Block diagram of differential fiber-optic sensors; a) with an electrical interface, b) with an optical interface

and second MC correspondingly, where photoelectric conversion occurs. Electric signals $I_1(X)$ and $I_2(X)$ are taken from the OEB outlet.

The electric signals at the BR1 and BR2 outputs are proportional to the intensity of the light fluxes coming at them from the measurement zone:

- $I(X)_{channel1} \sim \Phi(X)_{channel1}$
- $I(X)_{channel2} \sim \Phi(X)_{channel2}$
- $I(\alpha)_{channel1} \sim \Phi(\alpha)_{channel1}$
- $I(\alpha)_{channel2} \sim \Phi(\alpha)_{channel2}$

In order to improve accuracy characteristics, in processing a signal coming from a differential FOT, it is advisable to form the ratio of difference of the signals at the channel output to their sum:

$$\frac{I(X)_{channel1} - I(X)_{channel2}}{I(X)_{channel1} + I(X)_{channel2}},$$

$$\frac{I(\alpha)_{channel1} - I(\alpha)_{channel2}}{I(\alpha)_{channel1} + I(\alpha)_{channel2}}$$

In this case, there is a doubling of transformation sensitivity; the impact of radiation, uninformative FOC bends, changes in the ES emission power and BR sensitivity on the measurement accuracy is reduced, as these factors cause proportional variations of signals in the channels they do not lead to changes in the relations of signals.

Based on the generalized block diagram of a differential FOS, there are elaborated FOT structural models with various OEMs for measuring different physical quantities. As an example, Fig. 6 provides a block diagram of a differential Fiber-Optic Vibration sensor (FOVS) with a ball lens moving along the axis X (Murashkina *et al.*, 2008).

RESULTS AND DISCUSSION

The operating principle of the differential FOVS is the following. Electric signal U_i coming to the vibration sensor's OEB input is transformed into an optic signal Φ_0 by ES electro-optical transducer and is sent over IOF to the OME measurement zone. Under vibration, the ball lens moves in Z-direction between IOF and OOF and the conditions of light ray propagation in the lens body change (Badeeva *et al.*, 2003).

The light fluxes $\Phi_1(Z)$ and $\Phi_2(Z)$ go through the upper and lower halves of the ball lens, respectively. Then, over the OOFs of the corresponding first and second MCs and through the optical connectors OC1 and OC2, they arrive at the BR1 and BR2 of the corresponding first and second MCs, where they are converted to equivalent photocurrents $I_1(Z)$ and $I_2(Z)$. Later, the photocurrents are transformed to voltages $U_1(Z)$ and $U_2(Z)$ by photocurrent-voltage transducers PVT1 and PVT2 of the first and second MC correspondingly; here $U_1(Z)$ and $U_2(Z)$ are amplified to the required value (Fig. 6).

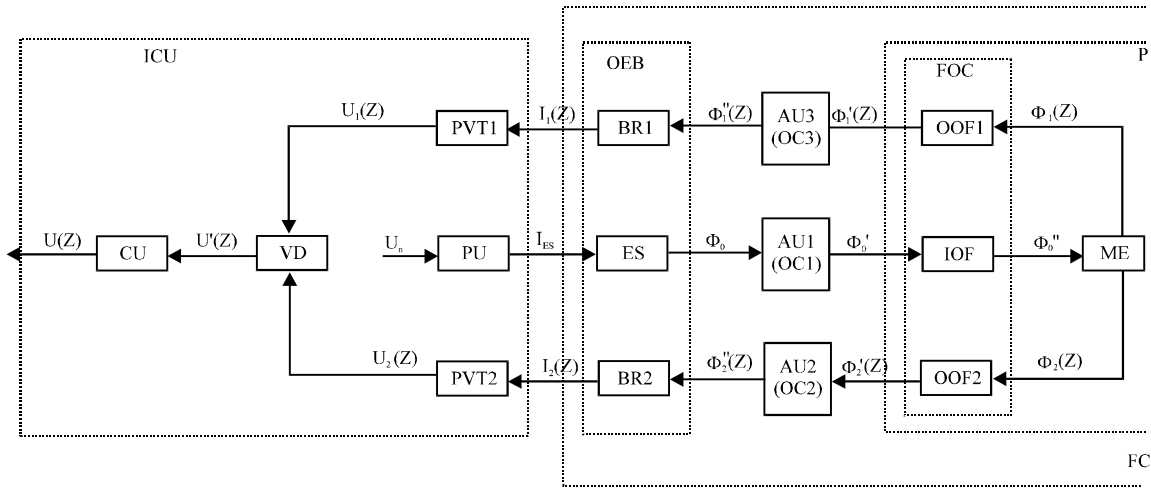

Fig. 6: Block diagram of a differential FOVS; PVT1, PVT2: Photocurrent-Voltage Transducers; VD: Voltage Divider; CU: Coefficient Unit; ICU: Information Conversion Unit; OEB: Optoelectronic Block; FOC: Fiber-Optic Cable; FOVS: Fiber-Optic Vibration Transducer; PU: Power Unit; ES: Emitting Source; AU1, AU 2, AU 3: Alignment Units; OC1, OC 2, OC 3: Optical Connectors; IOF: Input Optic Fiber; ME: Modulating Element; OOF1, OOF2: Output Optic Fibers; BR1, BR2: Beam Receivers

Then the signals $U_1(Z)$ and $U_2(Z)$ go the voltage divider VD, at the output of which the signal $U(Z)$ is measured. Its amplitude indicate the presence of vibration a in the measurement zone.

CONCLUSION

Differential transformation of optical signals significantly improves the metrological characteristics of the optical fiber sensors which operating principle is based on change in optic signal intensity under the influence of a measured physical quantity. This process makes them competitive in the conditions of radiation, high temperatures or strong electromagnetic fields and in intrinsically, explosion or fire unstable conditions as well.

ACKNOWLEDGEMENTS

This research has been performed with the financial support of the Russian Foundation for Basic Research (Grant 15-08-02675).

REFERENCES

Badeeva, E.A., A.V. Gorish, A.N. Kotov, T.I. Murashkina and A.G. Pivkin, 2004. Theoretical Bases of Designing an Amplitude Pressure FOS with an Open Optical Channel. Moscow State Forest University, Moscow, Russia.

Badeeva, E.A., L.N. Kolomiets, N.P. Krivulin, T.I. Murashkina and A.G. Pivkin, 2008. Development of Theory of Light Flux Distribution in the Optical System of Reflection-Type Fiber-Optic Transducers of Physical Quantities. Penza State University Information and Publishing Center, Penza, Russia.

Badeeva, E.A., V.A. Meshcheryakov, T.I. Murashkina and A.G. Pivkin, 2003. Attenuator-type pressure FOS for aircraft. Datchiki Sistemi, 4: 11-14.

Kolominets, L.N., E.A. Badeeva and T.I. Murashkina, 2007. On implementing differential transformation of signals in reflection-type fiber-optic pressure transducers. Datchiki Sistemi, 3: 26-28.

Murashkina, T.I. and A.G. Pivkin, 2005. Attenuator-Type Fiber-Optic Pressure Sensors for Rocket Engineering. Penza State University Publishing House, Penza, Russia.

Murashkina, T.I., V.D. Zuev and N.P. Krivulin, 2008. Displacement FOS with a spherical lens. Datchiki Sistemi, 5: 8-10.

Yurova, O.V., A.V. Arkhipov, I.T. Nazarova and T.I. Murashkina, 2011. Theoretical studies of a reflection-type angular displacement fiber-optic transducer. Ind. Automatic Control Syst. Controllers, 10: 48-51.