

## Processing of Ferromanganese Concretions with the Use of Sulfatizing Roasting

Alexey A. Darin and Nail M. Telyakov  
Saint Petersburg Mining University, 21 Line 2, 199106 St. Petersburg, Russia

**Abstract:** This study shows the possibility of processing of alternative manganese ore sources (Ferro Manganese Concretions (FMC) by applying leaching after preliminary sulfatizing roasting. The researches was carried out with tests of ferromanganese concretions from clarion-clipperton field (Pacific ocean). The results of the elemental analysis of the samples and results of researches of material structure of oceanic concretions and the results of large-scale researches of development of complex technology of processing are given. The results of researches of sulfatization and adsorption properties and the possibility of using in purify waste gases also shown. The study shows the possibility of achieving high levels of manganese and non-ferrous metals extraction in the application of the method and advanced research the possibility of using nodules as a sorbent for capturing sulfur dioxide in the flue gas.

**Key words:** Ferro manganese concretions, sulphatizing roasting, sulfatization, concretions of the pacific ocean, processing technology, manganese, pyritic concentrate, manganese ores, oceanic ores

---

### INTRODUCTION

Stocks of Ferro Manganese Concretions (FMC) in the oceans can solve the problem of shortage of manganese ore resources. The main field of deep-FMN is concentrated in the basins of the Pacific, Indian and Atlantic oceans at depths up to 5000 m. The clarion-clipperton field of greatest practical interest, its estimated reserves reach 600 mln. tonnes of dry ore mass. Concretions of this zone contain Mn, Ni, Co more than the entire global continental base stocks of these metals. A number of research and training institutions are recorded to have investigated technologies of ferromanganese concretion processing due to the practical needs in this field. There are research results of pyrometallurgical, bacterial, dithionic and sulphate and other methods of iron-manganese concretion processing as well as the evaluation of availability of net manganese concentrate in scientific literature. However, the technology based on sulphatizing roasting has a few obvious advantages. They are the following: a high rate change of manganese and non-ferrous metals into soluble state and unconstrained distilling of the obtained solutions from iron and other compounds. The most significant experimental observations in this field have been given close consideration in studies (Tseretelly, 1984; Telyakov *et al.*, 2016, 2003, 2015).

### MATERIALS AND METHODS

On the basis of these investigations, the technology capable of manganese sulphatization when roasting

pacific iron-manganese concretions using pyrite concentrates in the presence of steam-and-gas mixture containing 10% SO<sub>2</sub> vol. in fluidized bed has been developed. The analysis involved has covered the temperature range from 500-600°C during 60-120 min. The rate of steam-and-gas mixture consumption was about 1 dm<sup>3</sup> min g<sup>-1</sup> of iron-manganese concretions. Under these conditions manganese and non-ferrous metals (such as cobalt, nickel and copper) were sulphatized effectively.

If the steam-and-gas mixture had aforesaid composition, manganese would change into water-soluble sulphate. During the process of roasting the basic part of manganese (70-80%) changes into sulphate. The remaining part of manganese being the acid-soluble compounds which can be dissolved by sulphurous acid. The sulphurous acid is formed when it flows through furnace gases suspension. It is recommended to extract concentrates from manganese sulphate solutions by settling them down with ammonia solution (Telyakov, 1997).

### RESULTS AND DISCUSSION

Scaled-up tests of sulfatizing roasting were conducted on a fluidized-bed reactor at 500°C (Fig. 1). The raw materials were FMC from the clarion-clipperton field in the Pacific Ocean (Fig. 2). Results of researches of composition (Table 1) material structure of concretions obtained with application of thermogravimetric and x-ray diffraction analysis.

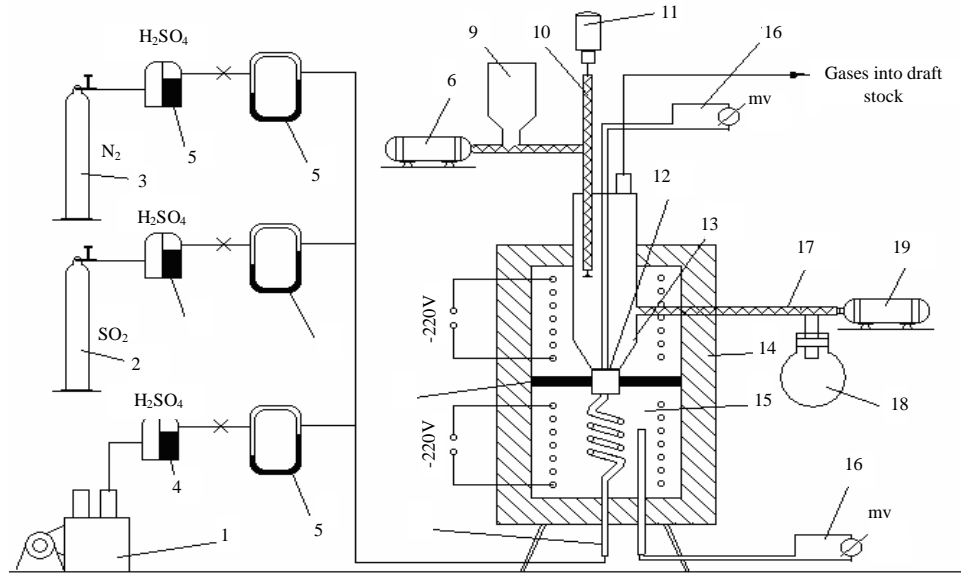

Fig. 1: Model of a continuous integrated laboratory-scale furnace: 1-Air-blast; 2-Balloon of SO<sub>2</sub>; 3-Balloon of nitrogen; 4-Tishchenko's flask of H<sub>2</sub>SO<sub>4</sub>; 5-Rheometer; 6-Feeder drive; 7-Heat insulating material; 8-Gas supply fitting; 9-Heating chamber; 10-Scroll feed; 11-Feeder drive; 12-Gas distribution breaker plate; 13-Reaction chamber; 14-Furnace mantle with heat insulation; 15-Feed bin; 16-Thermocouple complete with potentiometer; 17-Discharging device screw; 18-Outloading bunker; 19-Discharging device drive

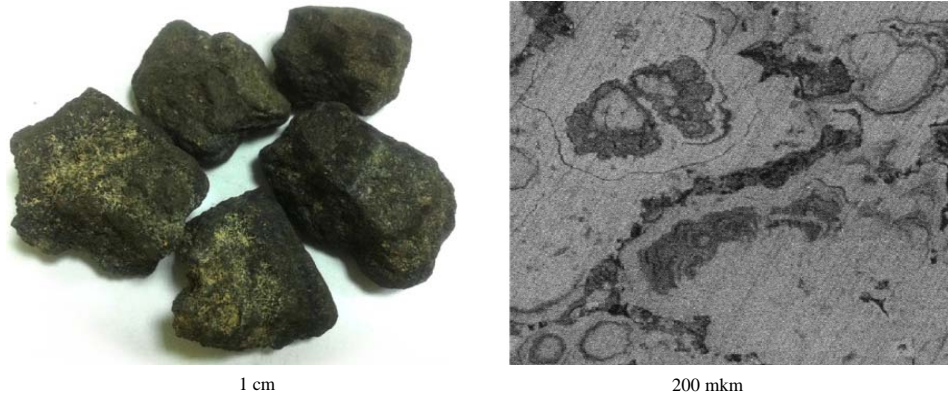

Fig. 2: Ferro manganese concretions of clarion-clipperton field

Table 1: Chemical composition sample ferromanganese concretions of the Pacific ocean

Variable	Mn	Fe	Ni	Cu	Co	Ti	Na	Mg	Al	Si	Cl	K	Ca
Wt.%	25.92	11.33	1.75	1.09	0.27	1.21	4.32	4.02	4.72	15.65	0.84	1.27	3.64

The concretions along with pyrite concentrates were treated with the gas mixture containing SO<sub>2</sub> and some air at the temperature range from 500°C. Due to the results of iron-manganese concretion sulphatizing roasting obtained during the research this method can be used to extract non-ferrous metals and manganese and change them into the aqueous phase from either the roasted product or

dust. The sulphatization ratio of nickel, copper, cobalt, manganese and ferrum is 95.2, 90.4, 99.6, 99.4 and 6.9%, respectively. Leaching was conducted in a single stage at a temperature of 60-80C, pH = 1, 3-1, 8 (Table 2). The adsorption properties of iron-manganese concretions and the hypothetical possibility of using for effectively reducing of the amount of sulfur dioxide in the waste gas

Table 2: Results of leaching

Variable	Ni	Co	Cu	Fe	Mn
Extraction (%)	90.80	97.92	80.11	26.38	99.52

during roasting have been investigated in the laboratory-scale furnace of fluidized bed in continuous mode. The initial moisture content of nodules was 16.5-16.7% which corresponds to the natural drying on an industrial scale. Aforementioned information indicates that the mechanism of SO<sub>2</sub> and iron-manganese concretion interaction is chemical sorption at the specific temperature range.

About 3 g shots of the iron-manganese concretions were treated with sulphur dioxide-and-gas mixture (10% of SO<sub>2</sub>). The material was disboarded and weighed after the experiment. Besides sulphur, manganese and non-ferrous metal content of the material was analysed. The adsorption properties of iron-manganese concretions was studied according to the increase of sulphur content in scoria after the process of roasting. The experiments were carried out with blast consumption that excluded the influence of outer diffusion medium. The sulphur content in the roasted product appeared to be increasing from 0.15-3, 1-3.5% in the initial test sample while there was a steady-state flow of iron-manganese concretions and gas mixture at the temperature range from 100-150°C and 5-6, 9% at the temperature range from 250-300°C. Adsorptive capacity of iron-manganese concretions were determined by means of their sulphatizing roasting during the trial research at SSGOK. The content of SO<sub>2</sub> in waste gases was noticed to be rather small (0.4-0%) (Telyakov *et al.*, 2003).

### CONCLUSION

In summary, the results of complex researches show the possibility of processing with application of

sulphatizing roasting in “boiling bed” and the leaching for oceanic concretions containing non-ferrous metals. Produced high levels of sulfatation of manganese and non-ferrous metals in the burning step and high recoveries in the leaching step. Furthermore, it ought to be remarked that the experimental analysis has shown that ferromanganese concretions can be efficiently used to purify waste gases of iron and steel industry due to their high adsorptive capacity.

### REFERENCES

- Telyakov, A.N., A.A. Petukhov, A.A. Darin and N.M. Telyakov, 2015. [Selective sedimentation of manganese during the processing of phosphorous-containing ferromanganese concretions (In Russian)]. Metall. Metallurgist, 6: 29-32.
- Telyakov, N.M., 1997. Energy-saving technology of iron-manganese concretion processing. Mining J., 3: 15-19.
- Telyakov, N.M., A.A. Darin, A.N. Telyakov and A.A. Petukhov, 2016. Influence of the specific character of the content of iron-manganese concretions of the Pacific Ocean and Baltic Sea on technological indicators of valuable component extraction. Non Ferrous Metals, 2: 16-21.
- Telyakov, N.M., G.F. Rezvanov, L.M. Shalygin, M.V. Klementev and A.A. Darin, 2003. [Semi-industrial investigations of energy-saving technology for the processing of iron-manganese concretions (In Russian)]. Non Ferrous Metals, 7: 96-97.
- Tseretelly, A.V., 1984. Ways of low-phosphorus manganese raw material use. Manganese Min. Dressing Process., 6: 18-20.