

Capacitance Analysis of Tesla Coil Based on System Energy Method

Young Sun Kim

Department of Electrical and Electronic Engineering, Joongbu University, 10279 Goyang, South Korea

Abstract: Tesla coil is one of transformer with an air-core that generates a high voltage of several million volts by the principle of L-C resonant. Inductance of Tesla coil is determined by the shape and the number of turns of the coil. It occurs resonance phenomena when the inductance is same with capacitance. Therefore, it is necessary to calculate capacitance according to shape variable such as radius, diameter and height of toroid for the suitable use. In this study, we performed the electrostatic field analysis for the axis-symmetric model of Tesla coil to calculate capacitance using electrostatic energy relation. The capacitance of the Tesla coils was analyzed for single and double design variables. This study will be of great help in determining the dimensions and capacity for your application when designing Tesla coils.

Key word: Capacitance, electrostatic energy, energy method, L-C resonance, Tesla coil, axisymmetric

INTRODUCTION

A Tesla coil is one of the most renowned inventions in the world and was invented by Nikola Tesla around 1891. It is an air-core transformer which is composed of primary and secondary coils with an extremely high turn ratio and can generate a high voltage ranging from tens to millions of volts through the principle of resonance. The Tesla coil is used for the generation of high-voltage, low-current and high-frequency alternating-current electricity and can generate a high-voltage discharge and higher currents than other power supplies of an electrostatic generator (Plesca, 2013; Ranade *et al.*, 2016; Mehta and Patel, 2015). A Tesla coil is composed of two or three coupled resonant electric circuits. The coil can be used for electric lighting, phosphorescence, X-ray generation, high-frequency alternating current phenomena, electrotherapy, wireless electric energy transmission, etc. Tesla coil circuits were used commercially in spark-gap radio transmitters for wireless telegraphy until the 1920's and in medical equipment such as electrotherapy and violet ray devices. Today, Tesla coils are widely used for entertainment and educational displays as well. Although, the Tesla coil has not been commercialized in direct application, numerous studies have been conducted based on its theory and principle. Tesla coils are classified into the Spark-Gap Tesla Coil (SGTC), Solid State Tesla Coil (SSTC), Vacuum Tube Tesla Coil (VTTC), etc., according to the circuit compositions and elements used. In the spark-gap type, it is difficult to control the level of current induced in the secondary circuit (Tilbury, 2008; Craven, 2014). To convert an uncertain power output into the required form,

a debugging process of a completely manufactured Tesla coil is required (Johnson, 1990). This requires a significant investment of time.

A Tesla coil is a transformer that generates a high voltage of millions of volts using the principle of L-C resonance. Therefore, the inductance is calculated once the radius and number of turns of an inductor coil are determined and a resonance phenomenon occurs as the corresponding capacitance is determined. Therefore, in order to design a Tesla coil for a specific usage, the electrostatic capacity must be calculated in accordance with variables such as the size of the coil, position of the secondary coil, radius and the distance from the grounding electrodes (Kolchanova, 2002; Craven *et al.*, 2014). In this thesis, a Tesla coil was set as an axisymmetric model of an electrostatic field and an electromagnetic field analysis was conducted to calculate the electrostatic capacity. The electrostatic capacity for each variable was calculated based on the relations between the total electrostatic field energy and the electrostatic capacity. Thus, the optimal dimensions of a Tesla coil were determined.

MATERIALS AND METHODS

Tesla coil

Basic circuit and composition: A Tesla coil is a device that generates a high voltage ranging from tens to millions of volts. It is composed of six basic components: a high voltage transformer, high voltage capacitor, spark-gap, primary coil, secondary coil and toroid. When the Tesla coil is activated, the primary high-voltage transformer converts a domestic Alternating-Current Voltage, (ACV = 220 V) into tens of thousands of volts (40,000 V

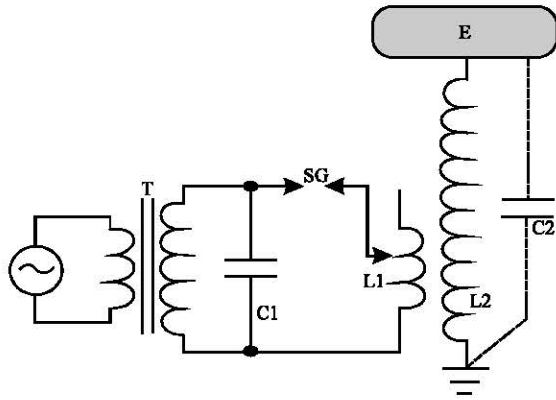

Fig. 1: Composition of L-C resonance circuit

in the case of Tesla coil at the Gwacheon National Science Museum). The converted energy charges a high-voltage condenser. When the charge reaches a level sufficient to flow across a spark gap, a spark is produced between the gaps and a closed circuit is established between the condenser and the primary coil. Here, the energy stored in the condenser is transferred to the primary coil and an electromagnetic field is formed between the primary and secondary coils. This process is repeated with the spark discharge rotating rapidly from a hundred to a thousand times per second in the spark gap. The secondary coil absorbs the energy through the electromagnetic field formed between the primary and secondary coils, resulting in an amplified voltage. Figure 1 shows the L-C resonant circuit of the Tesla coil.

The primary and secondary coil of Tesla coil: The composition and characteristics of a Tesla coil are described in this section. The primary coil is an inductor component of the primary circuit and forms a resonance circuit in combination with the primary capacitor. In general, a copper tube or thick wire is used because all energy stored in the primary capacitor is consumed and it has to withstand a high-current pulse. It is designed in a structure that allows for adjusting the inductance according to the resonance frequency. The primary capacitor stores energy from the power supply to enable spark production in the spark gap. An insulator that can withstand the voltage of the primary circuit which ranges between 1-22 kV is generally, required. The spark gap is used to switch a low frequency of the supplied power to a high frequency and a rotary type is also used to control the switching speed. The secondary coil is used to increase the voltage. This is an air-core inductor with a winding that is generally wound for 500-2,500 turns.

Table 1: Primary circuit parameters

Part/Parameter	Values
Inductor	
Wire diameter	12 mm
Turn spacing	10 mm
Inner diameter	225 mm
Capacitor	
No. of primary coil	6.25 turn
Primary inductance	17.05 μ H
Primary capacitance	0.33 μ F

The size of the winding is determined in accordance with the structure of the required Tesla coil. In general, a PVC tube is used, along with thick paper, glass, polypropylene, etc. Multiple layers of varnish are coated as well in order to prevent insulation or corona discharge. The top load is a capacitor of the secondary circuit which forms a resonance circuit with the secondary coil at the same frequency as the primary circuit. The secondary capacitance decreases because the size of the inductor of the secondary circuit is significantly larger than that of the primary circuit. The design of the coil needs to be in a smooth form such as a plate, sphere, toroid, etc., to allow for the storage of energy. The high level of energy stored in the metal body through a discharge needle is discharged into the atmosphere. Table 1 shows the design variables of the primary circuit of a manufactured Tesla coil.

According to the circuit diagram of a Tesla coil, the coil is composed of two L-C circuits. The L-C circuit consists of a condenser and a coil and it has the characteristic of producing resonance under certain conditions. The primary L-C circuit of the Tesla coil functions as an oscillator composed of a condenser, spark gap and the primary coil. The secondary L-C circuit functions as a resonance circuit composed of the secondary coil and a toroid. Together, the toroid connected to the top and the ground connected to the bottom of the secondary coil function as a condenser. Strong discharge sparks in the toroid are caused by the voltage which is amplified when the secondary L-C circuit is at its resonant frequency. In this process, an extremely loud noise is generated owing to the expansion of the air.

The discharge voltage of a Tesla coil is proportional to the size of the top load of the secondary circuit and is generally determined by Eq. 1. In this thesis, a top load with a diameter of 250 mm was applied for discharge voltages of 350 kV or higher. Table 2 lists the design variables of the secondary circuit of a manufactured Tesla coil and Fig. 2 shows the manufactured Tesla coil.

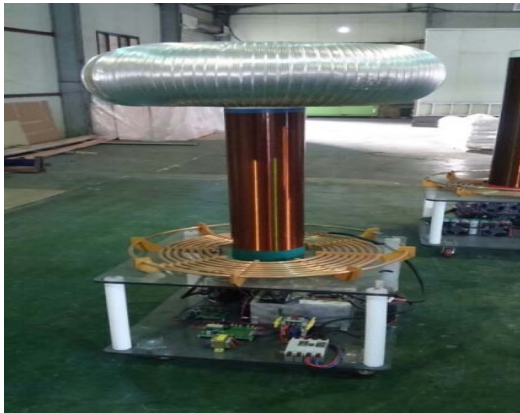

Fig. 2: Manufactured Tesla coil

Table 2: Secondary circuit parameters

Parts/Parameter	Values
Inductor	
Radius of secondary coil	108.5 mm
Height of secondary coil	790 mm
Number of turns for secondary coil	1760 turn
Secondary inductance	161.74 mH
Capacitor	
Diameter of top load	900 mm
Height of top load	250 mm
Secondary capacitance	39.39 pF

Table 3: Electrical specifications

Part	Values
Input voltage	220 V/60 Hz
Rectified voltage	420 V
Primary circuit	
Capacitance	0.33 uF
Inductance	17.05 uH
Resonant frequency	66 kHz
Secondary circuit	
Capacitance	39.39 pF
Inductance	161.74 mH
Resonant frequency	63 kHz

$$V [kV] = 1.5(kV) \times D[mm] \quad (1)$$

Where:

V = The maximum discharge voltage

D = The diameter of a top load

To determine the physical size of the primary coil, the inductance of the primary circuit was calculated using the expression above and a capacitor was determined to have the same resonant frequency as that of the secondary circuit. Table 3 lists the electrical specifications of a Tesla coil.

RESULTS AND DISCUSSION

Numerical analysis: In this study, the calculation method for the capacitance using an energy relation and an analytical method of the electromagnetic field for a Tesla coil system are explained.

Relations of electrostatic energy and capacitance: A capacitor is a device that can store electric potential energy in an electric circuit. In general, the inside of a capacitor is composed of two conductive plates located separately with an insulator between them. The charge is stored on the surface of each plate. The boundary of an insulator and the amount of charge accumulated is the same on both sides while the signs are opposite. When voltage is applied between the two conductive plates, a (-) charge is induced at the cathode and a (+) charge is induced at the anode. This produces electrical attraction. Such an electrical attraction between charges enables the storage of energy.

A certain process is required when transferring electrons from one plate to another in an uncharged capacitor. However, an electric field is formed whenever charges are transferred and this leads to a requirement for more processing. If the amount of charge (q) is to be transferred from one plate to another at a certain time, the difference in voltage between the two plates is as follows:

$$v = \frac{q}{C} \quad (2)$$

The power generated by a capacitor can be calculated as follows:

$$P_c(t) = v(t) i(t) = C v(t) \frac{dv(t)}{dt} = \frac{d}{dt} \left(\frac{1}{2} C v^2 \right) \quad (3)$$

Where:

v = The voltage at both ends of the capacitor

C = Capacitance

If both ends are integrated, the energy W stored in the capacitor is as follows:

$$W = \int P(t) dt = \frac{1}{2} C v^2 \quad (4)$$

The electrostatic capacity can be obtained through the expression:

$$C = \frac{2 W}{v^2} \quad (5)$$

The energy can be calculated by integrating the multiplied values of the electric flux density and electric field as the area of analysis using the result of the electric field analysis:

$$W = \frac{1}{2} \int_v D \times E dv \quad (6)$$

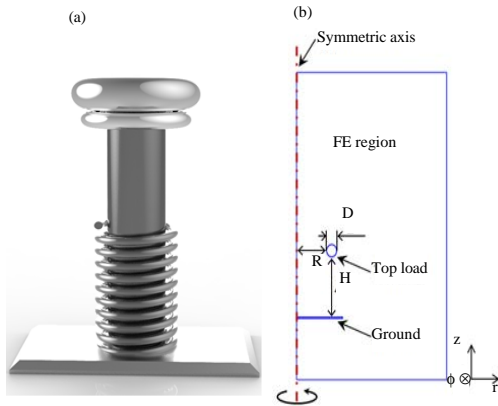

Fig. 3: Modeling for electric field analysis of Tesla coil; a) Analysis model and b) Axis-symmetric model

Analysis of electrostatic field: To calculate the capacitance of a Tesla coil, a finite element analysis of the electromagnetic field must be conducted first. COMSOL’s Multiphysics Software was used for this analysis. An axisymmetric 3D Model was applied because the Tesla coil has a structure in which the primary and secondary coils and a bobbin are symmetrical around the central axis. An analysis of the electrostatic field was conducted using electric scalar potential.

The governing equation for the analysis of an electrostatic field is Poisson’s equation and the electric field is formed by charges and boundary conditions. The equation is expressed as follows:

$$\nabla^2 V = -\frac{\rho_v}{\epsilon_0} \quad (7)$$

Where:

- V = Electric scalar potential (V)
- ρ_v = Volume charge density (C/m³)
- ϵ_0 = Permittivity of the air

Figure 3 shows the axisymmetric 3D Model used to analyze the structure and geometry for numerical analysis. This information is used in an analysis of the electric field of a Tesla coil. In this study, the forcing term was absent owing to charge does not exist and 300,000 V was applied to the top load as the boundary condition for electrostatic field analysis.

In the finite element analysis, the design input, boundary condition setting, region definition and element division are used in pre-processing. Figure 4a shows an element division chart (number of nodal

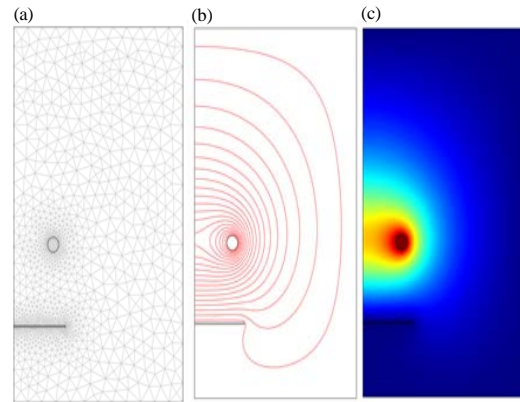

Fig. 4: Results of electric field analysis for Tesla coil; a) Mesh; b) Equi-potential line and c) Electric field intensity

Table 4: Range of design variables and reference values

Design variable	Range (mm)	Displacement value (mm)	Reference value (mm)
R (Radius)	210-390	20	310
D (Diameter)	30-210	20	110
H (Height)	100-1000	100	500

points: 1,344; number of elements: 2,610) of the analysis subject. Figure 4b which indicates the distribution of equi-potential lines and Fig. 4c which indicates the distribution of the electric field intensity are part of post-processing.

Capacitance analysis: The capacitance according to the design variables of the analysis subject was analyzed to study the resonant frequency of a Tesla coil. The obtained value can be used to design a secondary Tesla coil using an L-C resonant circuit. The design variables of the coil were set as the Radius (R), cross-sectional Diameter (D) and Height (H) of a toroid as shown in Fig. 3b. Table 4 lists the range, displacement value and reference value of the design variables. The range of dimensions was calculated by adjusting to approximately ±30% based on the reference value.

Figure 5 shows the calculation results for the capacitance when one of the design variables is changed (radius, cross-sectional diameter or height) for the toroid located at the top part of the Tesla coil. Figure 5a and b indicate that the capacitance increased when the radius and cross-sectional diameter of the toroid increased. Figure 5c shows that the capacitance decreased when the height of the toroid increased. In addition, the change in capacitance in relation to the design variable p was

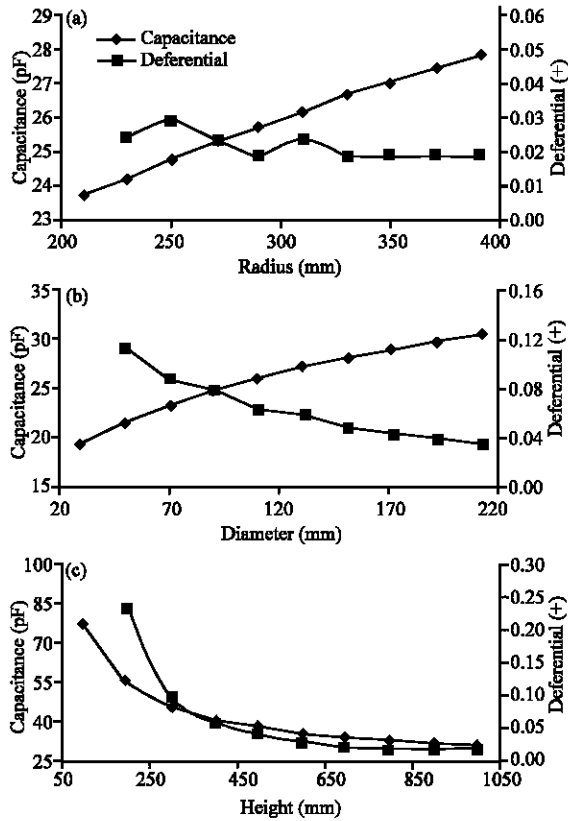

Fig. 5: Capacitance analysis according to single design variable; a) Design variable: Diameter of toroid (D: 110 mm, H: 500 mm); b) Design variable: Diameter of cross section of toroid (R: 310 mm, H: 500 mm) and c) Design variable: Height of toroid (R: 310 mm, D: 110 mm)

expressed as a differential value ($|dC/dp|$) to indicate the sensitivity of the capacitance to the changes in the design variables. The differential values for changes in capacitance for the radius of the toroid were relatively consistent, indicating that the capacitance showed a linear change in relation to the design variables. The sensitivity of the toroid to changes in the cross-sectional diameter decreased as the design variables increased, indicating that the capacitance showed a linear change once the variables increased to a certain level. The sensitivity to height showed a drastic change in the early stage and the characteristic of saturation was observed after a certain time point. Figure 6 changes were applied to multiple variables. Figure 6 shows the changes in capacitance in relation to the radius and cross-sectional diameter of the toroid, cross-sectional diameter and height of the toroid and radius and height of the toroid.

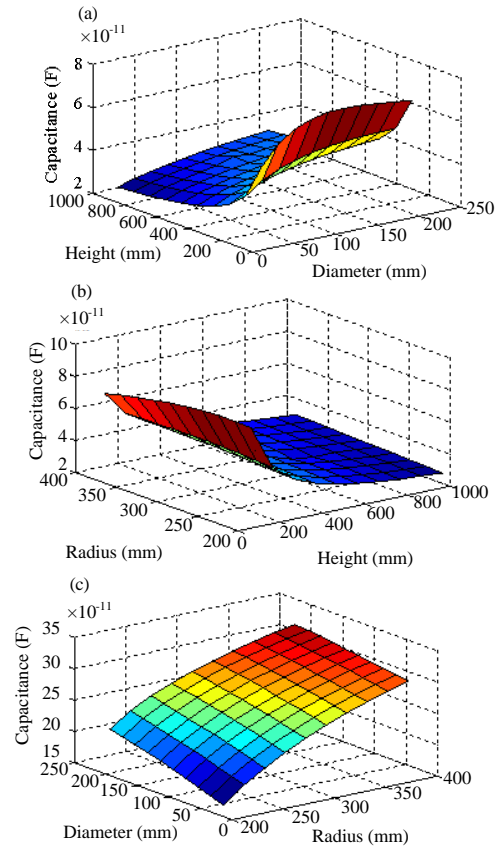

Fig. 6: Capacitance analysis according to dual design variables; a) Design variable: Diameter of cross section and height of toroid (R: 310 mm); b) Design variable: Diameter and height of toroid (D: 110 mm) and c) Design variable: Height and diameter of cross section of toroid (H: 500 mm)

CONCLUSION

A Tesla coil is a device that generates a high voltage ranging from tens to millions of volts as an air-core transformer circuit. The term resonance refers to an equilibrium state of the process in which the reactance and capacitance store, discharge and exchange energy through electric and magnetic fields in series and parallel L-C circuits. Therefore, calculating the capacity of inductance and capacitance is critical in the design of a Tesla coil. In this study, the capacitance was analyzed by applying changes to design variables of the toroid at the top of the coil. COMSOL's Multiphysics Software was used to analyze the electric field and the energy relationship expression was used to calculate the capacitance. The changes in the capacitance with regard to the radius, cross-sectional diameter and height of the toroid were analyzed.

RECOMMENDATIONS

The data obtained from the analysis are expected to be useful for the design of a Tesla coil for an intended use. It is also expected that additional studies for test-based validation and optimal design will be required in the future.

ACKNOWLEDGEMENTS

This research was supported by the Korea Institute of Energy Technology Evaluation and Planning (KETEP) and the Ministry of Trade, Industry and Energy (MOTIE) of the Republic of Korea (No. 2 0151220200010).

REFERENCES

- Craven, R.M., 2014. A study of secondary winding designs for the two-coil Tesla transformer. Ph.D Thesis, Loughborough University, Loughborough, England.
- Craven, R.M., I.R. Smith and B.M. Novac, 2014. Optimizing the secondary coil of a tesla transformer to improve spectral purity. IEEE. Trans. Plasma Sci., 42: 143-148.
- Johnson, G.L., 1990. Building the world's largest Tesla coil-history and theory. Proceedings of the 22nd Annual Symposium on North American Power 1990, October 15-16, 1990, IEEE, Auburn, Alabama, ISBN:0-8186-2115-X, pp: 128-135.
- Kolchanova, V.A., 2002. Computational modeling of the Tesla coil parameters. Proceedings of the 8th International Scientific and Practical Conference on Students, Post-graduates and Young Scientists Modern Technique and Technologies (MTT 2002), April 12, 2002, IEEE, Tomsk, Russia, ISBN:0-7803-7373-1, pp: 32-33.
- Mehta, H.D. and R. Patel, 2015. Optimal design of transformer using tournament selection based elitist genetic algorithms. Indian J. Sci. Technol., 8: 1-9.
- Plesca, A.T., 2013. Thermal analysis of overload protection relays using finite element method. Indian J. Sci. Technol., 6: 5120-5125.
- Ranade, A., E. Rajkumar and S. Gaikwad, 2016. Transformer tank optimization using design of experiments. Indian J. Sci. Technol., 9: 1-7.
- Tilbury, M., 2008. The Ultimate Tesla Coil Design and Construction Guide. McGraw-Hill Education, New York, USA., Pages: 412.