

## Design and Implementation of Automatic Underwater Multi-target Detection based on RESAN

R. Rajendr Prasad

Department of Marine Engineering, AMET University, Chennai, India

**Abstract:** Programmed ocean surface protest identification and following for safe self-sufficient submerged vehicle and submarine surfacing is a basic issue in connection to the mischance announced in the most recent decades. Here, we propose an effective device to identify and track ocean surface impediments by preparing forward-looking sonar pictures. The proposed technique can identify either still or moving items with and without wake. Recognition and following stages trade data keeping in mind the end goal to diminish the quantity of false alerts. Promising outcomes are gotten utilizing genuine information gathered adrift with different items and situations. This study goes for planning an underground question discovery on Raspberry Pi in view of Linux stage.

**Key words:** Raspberry Pi, multi target, RESAN 7125, ultra sound, items, information

---

### INTRODUCTION

**Existing system:** A strong obstacle identification and evasion framework is basic for long haul self-governance of self-ruling submerged vehicles (AUVs). Forward looking sonars are generally used to recognize and restrict deterrents. Be that as it may, high measures of foundation clamor and mess display in submerged conditions makes it hard to recognize deterrents dependably. Additionally, absence of GPS flags in submerged situations prompts poor confinement of the AUV. This means instability in the position of the snag with respect to a worldwide casing of reference.

Impediment avoidance of sonar frameworks are typically utilized as a part of a forward-looking mode to distinguish and maintain a strategic distance from object either gliding in the ocean segment or lying on the ocean floor. Programmed location and following of ocean surface impediments from forward sonar pictures is without a doubt an intriguing application that may help empower safe submarine and self-governing submerged vehicle (AUV) surfacing (Quidu *et al.*, 2007). Truth be told in the most recent decades, numerous mischance's have happened. A celebrated mishap was the impact between the Japanese vessel Ehime Maru and the submarine USS Greenville in 2001. Close to the impact, Ehime Maru sank. Nine of her crewmembers were slaughtered including four secondary school understudies. As far as anyone is concerned, no previous research has been distributed on safe AUV surfacing at any rate in open writing. In any case, some surface question discovery and

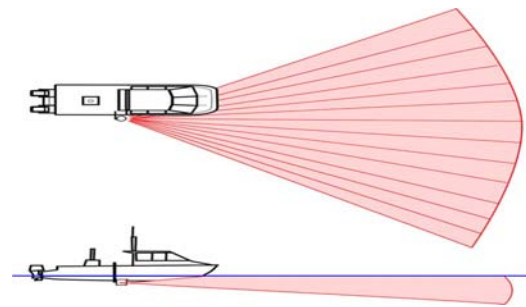

Fig. 1: Sonar configuration

characterization techniques exist for harbour observation. In any case, the greater part of these strategies depends on detached acoustic recognition (Trevorrow *et al.*, 1994). Dynamic sonar frameworks committed to the sea surface portrayal for the most part concentrate on test and hypothetical investigation of ship wake structure through the investigation of air pocket flow and backscattering and just a couple of late strategies have been proposed for programmed deliver recognition utilizing dynamic sonar pictures (Jones and Peterson, 2011). These techniques are fundamentally suited to a static arrangement for harbour surveillance purposes and they concern single ship identification. Here, we propose an example investigation method for programmed recognition and following of numerous surface items from forward-looking sonar pictures. The proposed strategy can distinguish still and moving vessels with or without self-commotion and wake (Fig. 1).

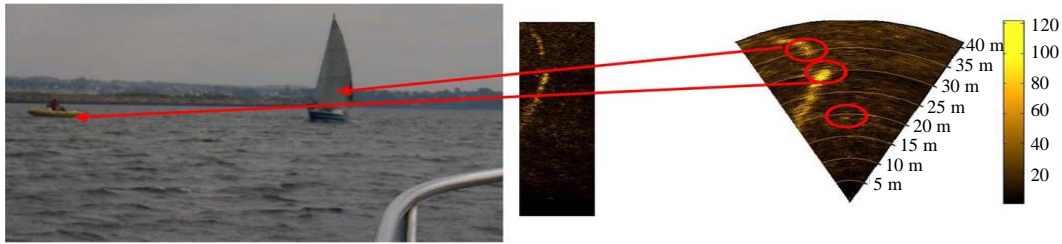

Fig. 2: Known surface objects

## MATERIALS AND METHODS

**Working principle:** Obstacle recognition is typically accomplished based on forward looking sonar. Such a framework is dynamic sonar that radiates a short acoustic heartbeat forward on a substantial flat area and a medium vertical segment. Acoustic echoes are recorded on a flat straight exhibit of transducers. A bar shaping procedure is connected on the recorded information to sort the acoustic vitality in time and point of entry. The envelope of the subsequent signs is then shown as a picture. That picture could be spoken to in polar directions or Cartesian directions. Here, we utilize the RESON 7125 sonar with the picture part mode. The sonar looks forward yet blocks the ocean surface. This sonar works at a focal recurrence of 240 kHz and a transfer speed of around 15 kHz (Lane, 2002). The even transmitting gap is wide and covers 150° on a level plane. The vertical opening is around 15°. Be that as it may, the recorded information just covers a vast area in the broadside bearing because of electronic data transfer capacity requirements. The shaft width for each of the got bars is 1.5° and the range determination is around 0.05 m. The overview vessel was moving gradually in the zone under scrutiny and information were recorded by different situations with various ocean surface articles: static man-made items laid on the ocean surface and moving ships and sailboats landing at or leaving the military harbour adjacent (Sedunoy, 2011). A location and following technique is proposed whatever the mark (Fig. 2).

## RESULTS AND DISCUSSION

The underwater acoustic images are often of low contrast and hence need to be enhanced in order to make the image suitable for effective segmentation. The Contrast Limited Adaptive Histogram Equalisation (CLAHE) has been exercised upon the filtered sonar images for segmentation process. Figure 3 shows the surface water autonomous navigator.



Fig. 3: Surface water autonomous navigator

## CONCLUSION

Ocean surface location and following by methods for forward looking sonar is a helpful application for safe AUV and submarine surfacing. In this study, we have proposed a programmed strategy for distinguishing and following different ocean surface targets: still and moving items with or without wake and cavitations commotion. Promising outcomes have been acquired with genuine information accumulated adrift.

## REFERENCES

- Jones, M.E. and M.E. Peterson, 2011. Extraction of boat harmonic signatures from passive sonar. *Acoust. Soc. Amer.*, 125: 3768-3776.
- Lane, D.M., 2002. Underwater obstacle avoidance and path planning using a multi-beam forward looking sonar. *IEEE. J. Eng.*, 27: 1194-1199.
- Quidu, I., A. Hetet, Y. Dupas and S. Lefevre, 2007. AUV redormor obstacle detection and avoidance experimental evaluation. *Proceedings of the IEEE International Conference on Oceans*, June 18-21, 2007, IEEE, Aberdeen, Scotland, ISBN:978-1-4244-0634-0, pp: 1-6.
- Sedunoy, A., 2011. Acoustic ship signature measurements by correlation method. *Acoust. Soc. Amer.*, 127: 774-778.
- Trevorrow, M.V., S. Vagle and D.M. Farmer, 1994. Acoustical measurements of microbubble with in ship wakes. *J. Acoust. Soc. Amer.*, 94: 1922-1930.