

Adaptive Variable Gain Based Fuzzy Proportional Plus Integral Current Control for Shunt Active Power Filter Operation

¹Harsha Vanjani, ¹Meha Sharma and ²U.K. Choudhry

¹Department of EEE-ECE, Ansal University, Gurgaon, India

²Department of EEE, HMR Institute of Technology and Management, Delhi, India

Abstract: Shunt Active Filter (SAF) has been used since last decade for power quality improvement. This study gives variable gain based fuzzy PI controller to control SAF to reduce total harmonic distortion factor whose level goes high when power electronic based non-linear loads are connected with the supply. Three phase voltage source inverter is designed to provide 180° shifted waveforms of the harmonics generated in the system. Performance of the SAF depends on DC link voltage control. The results of DC link voltages are compared with PI controller. This is all simulated with non-linear loads like bridge rectifier in continuation with unbalanced loads. The inferences prove that the SAF together with variable gain based fuzzy PI controller work effectively for different firing angles of non-linear load.

Key words: Active power filters, Fuzzy Logic Controller (FLC), PI, Total Harmonic Distortion (THD), Voltage Source Inverter (VSI), link

INTRODUCTION

Harmonics present in the power system are major concern in this modern era. All industries and house hold appliances are stocked with power electronic based devices which are very helpful and easy to handle. These power electronic based devices insert harmonics in the power system which deteriorates wave shape of the supply current. This in turn affects the power factor and voltage for the consumers at the end point (Singh *et al.*, 2014).

Initially passive filters were used to abolish the harmonics from the power system. Their size is large and provides fixed compensation. SAF are capable to eliminate harmonics generated by variable non-linear load. SAFs are quite effective in eliminating harmonics from the power systems. These filters when connected in series compensate for voltage harmonics and in parallel they compensate for current harmonics. Here, the current harmonic problem is corrected as it is more severe and quite complicated. The SAF is capable of improving the sinusoidal nature of supply current and balances it despite a non-linear load connected to it.

Usage of fuzzy logic controllers to control SAF has been increased in the last few years because of its advantages like it particular mathematical model is not required, the linguistic terms are natural (Jain *et al.*, 2002; Anjana and Maya, 2016). Conventional controllers based on PID gives quick response in steady state but in transient state it overshoots. In addition to that if load fluctuates, it is required to change values of PID

controller's constants for better performance (Vanjani and Choudhry, 2014; Chaoui *et al.*, 2007). Here, fuzzy logic based PID controller has been designed which varies values of constants automatically. So, the system works as variable gain fuzzy logic controller. Here, gain of the PI controller is varied using fuzzy logic control which in effect sets the K_p , K_i , K_d depending on the variable load of bridge rectifier. The PI controller along with Reactive Power Theory (RPT) extracts the fundamental component of load current and fixes the DC-link capacitive voltage of the voltage source inverter to a required constant level.

MATERIALS AND METHODS

Reference source current generation theory: The theory behind the generation of reference current for SAF depends on compensation principle. It compensates the current such that the supply current becomes pure sinusoidal again which was distorted by non-linear load. Figure 1 shows SAF working as compensator. Kirchoff's law can be applied at point of common coupling to calculate source current in terms of compensating current:

$$i_a(t) = i_b(t) - i_c(t) \quad (1)$$

Source current is $i_s(t)$ and load current $i_b(t)$, $i_c(t)$ is compensating current generated by SAF. So, compensating current in terms of source current is written as:

$$i_c(t) = i_b(t) - i_a(t) \quad (2)$$

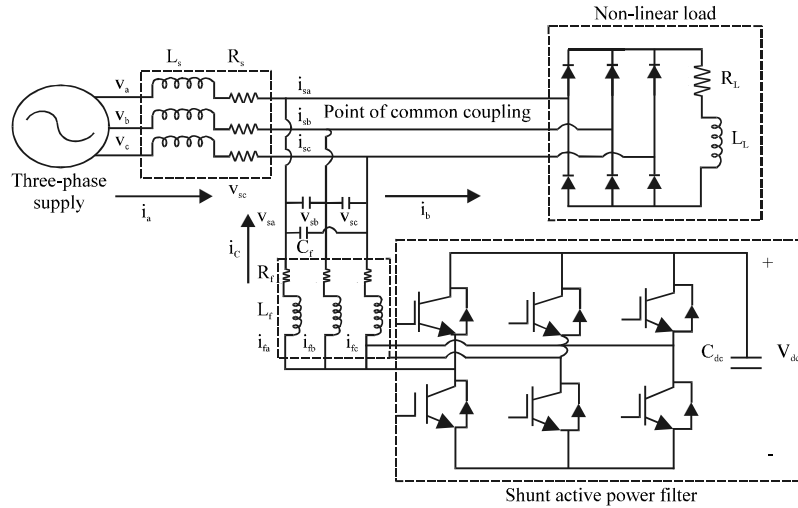

Fig. 1: SAF as compensator

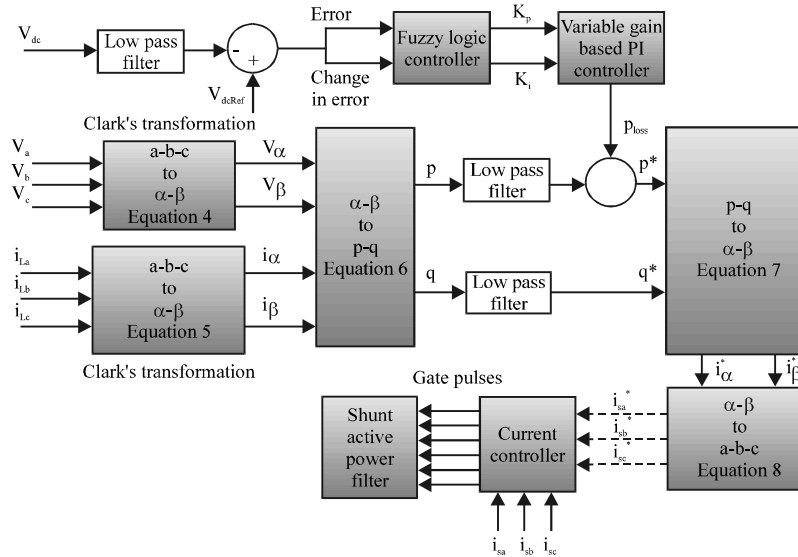

Fig. 2: Block diagram of proposed technique

The productivity of the controller is on calculation of reference current:

$$i_a(t) = i_m \sin(\omega t) \quad (3)$$

i_m can be valued by comparing the DC link voltage with its reference value. Here, the Clarke transformation is used to calculate the results. In the Clarke transformation, three-phase load voltages V_{sa} , V_{sb} , V_{sc} and load currents I_{La} , I_{Lb} , I_{Lc} is used to generate active power p and reactive power q according to following equations (Akagi *et al.*, 2007):

$$\begin{bmatrix} V_\alpha \\ V_\beta \end{bmatrix} = \sqrt{\frac{2}{3}} \begin{bmatrix} 1 & -\frac{1}{2} & -\frac{1}{2} \\ 0 & \frac{\sqrt{3}}{2} & -\frac{\sqrt{3}}{2} \end{bmatrix} \begin{bmatrix} V_{sa} \\ V_{sb} \\ V_{sc} \end{bmatrix} \quad (4)$$

$$\begin{bmatrix} i_\alpha \\ i_\beta \end{bmatrix} = \sqrt{\frac{2}{3}} \begin{bmatrix} 1 & -\frac{1}{2} & -\frac{1}{2} \\ 0 & \frac{\sqrt{3}}{2} & -\frac{\sqrt{3}}{2} \end{bmatrix} \begin{bmatrix} i_{La} \\ i_{Lb} \\ i_{Lc} \end{bmatrix} \quad (5)$$

$$\begin{bmatrix} p \\ q \end{bmatrix} = \begin{bmatrix} V_\alpha & V_\beta \\ V_\beta & -V_\alpha \end{bmatrix} \begin{bmatrix} i_{L\alpha} \\ i_{L\beta} \end{bmatrix} \quad (6)$$

Figure 2 shows block diagram of proposed algorithm. Values of k_p and k_i are determined through FLC. A low pass filter is used to separate DC components p^* and q^* from p and q . The total active power loss in the is referred as p_{loss} . This component is produced by PI controller

hose gains are fixed by FLC. The reference currents i_{s2}^* , i_{sb}^* , i_{sc}^* are calculated using p^* and q^* from following equations:

$$\begin{bmatrix} i_{\alpha} \\ i_{\beta} \end{bmatrix} = \frac{1}{V_{\alpha}^2 + V_{\beta}^2} \begin{bmatrix} V_{\alpha} & V_{\beta} \\ V_{\beta} & -V_{\alpha} \end{bmatrix} \begin{bmatrix} p^* \\ q^* \end{bmatrix} \quad (7)$$

$$\begin{bmatrix} i_{sa}^* \\ i_{sb}^* \\ i_{sc}^* \end{bmatrix} = \sqrt{\frac{2}{3}} \begin{bmatrix} 1 & -\frac{1}{2} & -\frac{1}{2} \\ 0 & \frac{\sqrt{3}}{2} & -\frac{\sqrt{3}}{2} \end{bmatrix} \begin{bmatrix} V_{\alpha} & V_{\beta} \\ -V_{\beta} & V_{\alpha} \end{bmatrix}^{-1} \begin{bmatrix} p^* \\ q^* \end{bmatrix} \quad (8)$$

These are the reference currents which are used to produce gate signals for VSI by comparing them with currents taken by non-linear load. The signals of gate which are given to the IGBTs are generated via hysteresis current controller.

Control algorithms

PID controller: For reference, current generation calculation depends on the total power loss which is combination of switching and conduction loss denoted by ploss. Researchers have worked on control schemes such as dead-beat control, wavelet, sliding mode, delta-sigma modulation, etc. Here, performance of PI and variable gain based fuzzy logic controller is verified to set a general result for three-phase four-wire system. The PI controller is a combination of the P plus I controller. Its transfer function can be represented as given by:

$$H(s) = K_p + \frac{K_i}{s} \quad (9)$$

Where:

K_p = The proportional constant that determines the dynamic response of the DC-side voltage control

K_i = The integration constant that determines its settling time

The controller is tuned with proper gain parameters for estimating the magnitude of peak reference current I_m and to control the DC-link capacitor voltage of voltage source inverter. PI controller estimates I_m , this I_m is multiplied with RPT output determines the desired reference current.

Fuzzy logic controller: Fuzzy logic control was invented from fuzzy set theory in 1965. Therefore, the limitations of fuzzy sets can be undefined and often ambiguous; FLC's are most appropriate in application when accurate mathematical calculations are impossible. Figure 3 shows block diagram of FLC. The variable gain based

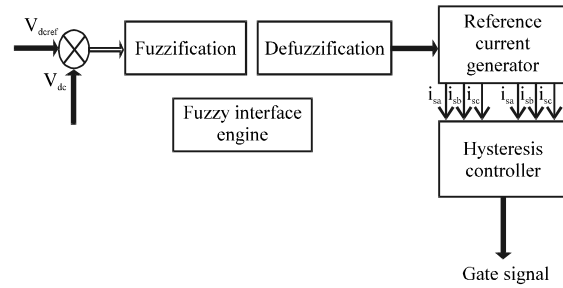

Fig. 3: Block diagram of combination of PI and fuzzy logic controller

Table 1: Fuzzy rules

V_{dc}	V_{dc}^{ref}						
	NB	NM	NS	Z	PS	PM	PB
NB	NB	NB	NB	NB	NM	NS	ZE
NM	NB	NB	NB	NM	NS	ZE	PS
NS	NB	NB	NM	NS	ZE	PS	PM
Z	NB	NM	NS	ZE	PS	PM	PB
PS	NM	NS	ZE	PS	PM	PB	PB
PM	NS	ZE	PS	PM	PB	PB	PB
PB	ZE	PS	PM	PB	PB	PB	PB

FLC is implemented using symmetrical triangular membership functions with 49 fuzzy rules and the centroid method.

Fuzzification: Fuzzification process uses linguistic variables in place of numerical variables. In a control system, the error observed between the reference DC voltage signal and the actual DC voltage signal can be denoted as Negative Big (NB), Negative Medium (NM), Negative Small (NS), Zero (ZE), Positive small (PS), Positive Medium (PM), Positive Big (PB). A triangular membership function is used for fuzzification. The process of fuzzification involves converting numerical variables (real number) into linguistic variables (fuzzy number).

Defuzzification: The rules of fuzzy logic controller generate required output as a new linguistic variable (fuzzy number), set according to real world requirements. Linguistic variables received from the system should be transformed to interpretable useful output which is a real number. The selection of strategy for this interpretation is copout between accuracy and computational intensity. The database stores the ranges of the triangular membership function demanded by fuzzifier and defuzzifier.

Rules: The linguistic rules are denoted as Negative Big (NB) to Positive Big (PB) are given in Table 1.

RESULTS AND DISCUSSION

Three phase SAF system is connected in parallel with the distribution network at the point of common coupling through filter inductances. The three-phase source is connected to the non-linear load having Total Harmonic Distortion (THD) of 16.76% as shown in Fig. 4. The parameters used in simulation are shown in Table 2.

The SAF estimates the fundamental component of the load current and thus compensates the harmonic current and reactive power; the source current will be in phase with the utility voltage and sinusoidal. The pursuance of the proposed PI and variable gain based FLC is evaluated by means of a simulation using Matlab/Simulink toolbox.

The source current without filter is shown in Fig. 4. The source current with filter is shown in Fig. 5 that indicates that the current becomes sinusoidal. In Fig. 5, the source current after introducing PI controller based SAF which reduces the THD to 3.43%, compared to the source current without PI based SAF is shown in Fig. 4 where the THD is 16.76%, the compensation current produced by the SAF to nullify the harmonic effect (The non-linear load considered is diode bridge rectifier). The performance of Variable gain based fuzzy PI controller is shown in Fig. 6.

Table 2: The parameters used in simulation

System parameter	Values
Source Voltage (V_s)	440 V
System frequency (f)	50 Hz
Switching frequency (f_s)	10 kHz
Source impedance (R_s, L_s)	1 Ω , 1.2 mH
Filter impedance (R_f, L_f)	2 Ω , 0.75 mH
Load impedance (R_L, L_L)	4 Ω , 20 mH
Reference DC link (voltage (V_{dc}))	650 V

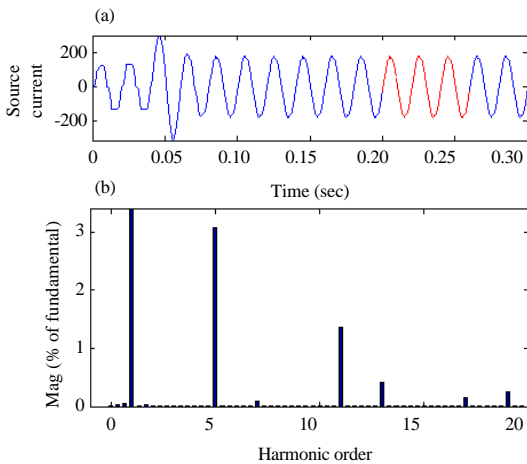

Fig. 4: Load current wave when SAF is connected: a) Selected signal: 15 cycles. FFT window (in red): 3 cycles (signal to analyze) and b) Fundamental (50 Hz) = 164.2, THD = 16.76% (FFT analysis)

Figure 6 shows that SAF better than to PI based SAF for change in load condition and %THD reduced to 2.32% with variable gain. The both PI and variable gain based FLC are able to control DC link voltage with sinusoidal source and load currents. But variable gain based FLC gives better result in transient condition with simple rule base.

The DC side capacitance current which is controlled by PI controller is shown in Fig. 7. From the results, it is clear that when SAF works with PI controller DC link voltage overshoots and takes more time to settle compared to Variable gain based fuzzy PI controller.

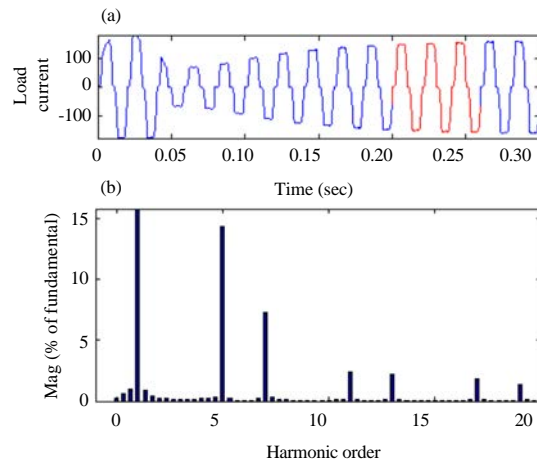

Fig. 5: Source current with SAF controlled with PI: a) Selected signal: 15 cycles. FFT window (in red): 3 cycles (signal to analyze) and b) Fundamental (50 Hz) = 180, THD = 3.43% (FFT analysis)

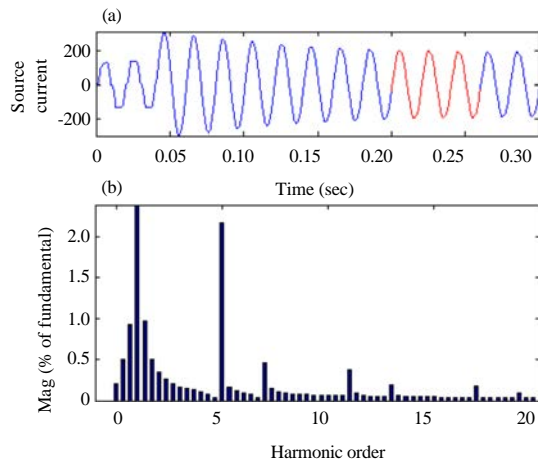

Fig. 6: Source current with SAF controlled by variable gain based Fuzzy PI controller: a) Selected signal: 15 cycles. FFT window (in red): 3 cycles (signal to analyze) and b) Fundamental (50 Hz) = 186, THD = 2.32% (FFT analysis)

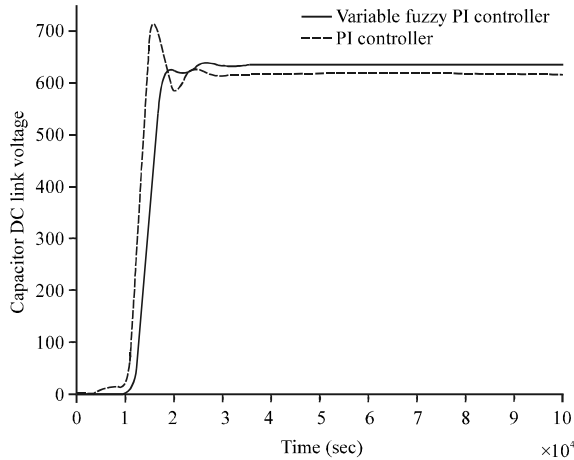

Fig. 7: DC link voltage of PI and variable fuzzy PI controller

The simulation is done for various non-linear and unbalanced load conditions. Variable gain based PI controller with RPT technique based compensator filter makes the source current balanced and sinusoidal after compensation. FFT analysis of the SAF confirms that the THD of the source current is compliance with IEEE-519 and IEC 61000-3 harmonic standards (IEEE Standards 519-1992, 1993; IEC., 1998).

CONCLUSION

The simulation study identified that variable gain based PI controller in conjunction with RPT technique based SAF facilitates improving power quality relative to PI. This controller ensures that the DC side capacitor voltage is highly stable (nearly constant) with small ripple besides extracting fundamental reference currents for any load condition. The performance of a variable gain based fuzzy PI controlled SAF system is verified and compared under non-linear and unbalanced loads with various parameters that are presented graphically. This approach brings down the harmonics described by international standards.

REFERENCES

- Akagi, H., E.H. Watanabe and M. Aredes, 2007. Instantaneous Power Theory and Applications to Power Conditioning. Wiley-IEEE Press, USA., ISBN-13: 978-0470107614, Pages: 379.
- Anjana, S. and P. Maya, 2016. Fuzzy logic control of shunt active power filter for power quality improvement. Proceedings of the International Conference on Soft Computing Systems, December, 29, 2016, Springer, Berlin, Germany, pp: 975-985.
- Chaoui, A., J.P. Gaubert, F. Krim and G. Champenois, 2007. PI controlled three-phase shunt active power filter for power quality improvement. Electr. Power Compon. Syst., 35: 1331-1344.
- IEC., 1998. Electromagnetic Compatibility (EMC)-Part 3-4: Limits-Limitation of emission of harmonic currents in low-voltage power supply systems for equipment with rated current greater than 16 A. IEC. International Electrotechnical Commission, Geneva, Switzerland.
- IEEE Standards 519-1992, 1993. IEEE recommended practices and requirements for harmonic control in electric power systems. IEEE Industry Applications Society, <http://ieeexplore.ieee.org/servlet/opac?punumber=2227>.
- Jain, S.K., P. Agrawal and H.O. Gupta, 2002. Fuzzy logic controlled shunt active power filter for power quality improvement. Proc. Electr. Power Appl., 149: 317-328.
- Singh, B., A. Chandra and K. Al-Haddad, 2014. Power Quality: Problems and Mitigation Techniques. John Wiley & Sons, Hoboken, New Jersey, ISBN:9781118922071, Pages: 600.
- Vanjani, H. and U.K. Choudhury, 2014. Performance analysis of three-phase four-wire shunt active power filter. Proceedings of the 2014 International Conference on Optimization, Reliability and Information Technology (ICROIT), February 6-8, 2014, IEEE, Faridabad, India, ISBN:978-1-4799-2995-5, pp: 496-500.