

“Parameter Identification of a Lithium-Ion Battery Model Using Levenberg-Marquardt Algorithm”

¹El Mehdi Laadissi, ¹El Filali Anas, ¹Malika Zazi and ²Khalfi Jaouad

¹Laboratory LM2PI, ENSET, Mohamed V University, Rabat, Morocco

²Department of Physics, Laboratory of Electrical Systems and Telecommunications, FST, Cadi Ayyad University Marrakech, Morocco”

Abstract: Now a days, lithium-ion batteries are the most used to power electronic devices and electric vehicles. Lithium-based electrochemical accumulators have better energy density and reliability than any other energy storage method. To use a battery effectively, it is necessary to understand its operation, its dynamics and to know the parameters that can affect its performance. In this study, we propose a model of a lithium-ion battery, the parameters of this model are identified by a Levenberg-Marquardt nonlinear algorithm. The parameter output is a lookup-table of element values that depends on the state of charge of the battery. A pulses discharge test is performed on a commercial 16 Ah lithium-ion battery in order to identify the parameters and validate the model, results are presented and validated.

Key words: Lithium-ion battery, battery modelling, parameter identification, Levenberg-Marquardt, simscape, model

INTRODUCTION

Due to technological progress and the rapid evolution of mobile systems, many habits are changing. The individual demands more and more portable applications. This new trend creates a strong demand for power supply that must be as efficient as possible whether in terms of reliability, charging time or discharge time and especially, the volume occupied. With respect to all these points, the lithium-ion battery appears to be the most suitable solution. After the bad start of lithium metal batteries in the early nineties, lithium-ion batteries, known as the safest batteries, quickly recovered the delay. Today, this technology is competitive with high-demand areas such as military and space applications.

In our new area, the storage and conversion of energy is a major challenge because the world's oil reserves will not be able to meet the needs of humanity for a long time. Hence, the interest of doing research to find new sources of energy less polluting and which respect our environment which is changing in a rather fast way.

One of the key components of the new generation of vehicles aimed at reducing emissions and conserving energy is the storage battery. The function of a storage battery in an application may vary. For example, in the case of the automotive industry, the storage battery may be the main source of power as the case of an electric vehicle or a secondary source used in conjunction with

another power source such as the electric engine and the combustion engine in the case of a hybrid electric vehicle (Lu *et al.*, 2013; Fotouhi *et al.*, 2017).

A Li-ion battery consists of several cells connected in series and in parallel depending on the voltage and the requirements of the device. Three different types of Li-ion battery cells are commonly used: cylindrical, prismatic and polymer, used in laptops, tablets and phones. In addition, lithium is the lightest metal. Lithium ion batteries are widely used in the notebook industry, cell phones and embedded systems because of their high energy density. Moreover, this type of storage battery has a good performance at high temperature and low self-discharge especially as they have no memory effect. The first accumulator batteries of this kind had relatively short lifetimes.

The first generation of rechargeable lithium batteries used a lithium anode in its metallic form. This technology has however, been abandoned because of the difficulty of reconstituting the anode during successive recharges. This once damaged could accidentally reach its melting point (180°C) and come into contact with the cathode which produced a violent reaction and the emission of hot gases. Abandoned for more than 10 years, lithium metal could make a comeback in a few years, if current research to find a solution to the security problem is successful.

To overcome the problems encountered in lithium metal batteries, the radical solution of abandoning lithium in metallic form at the level of the anode has been

adopted in favor of an insertion compound. Graphite appears as the best candidate for this role. Indeed, the carbon insertion properties have been demonstrated up to a Lithium ion for 6 Carbon atoms (LiC_6). During the first insertion of lithium into the graphite, a part is totally consumed irreversibly. This phenomenon is due to the decomposition of the electrolyte and the formation of a passivating film on the Surface of the Electrode (SEI film). Unlike the metal lithium anode, this phenomenon is essential for the good operation of the cell. SEI prevents the reduction of the electrolyte by retaining Li^+ ions in the carbon. However, this layer must be sufficiently porous to allow the Li^+ ions to pass during charge/discharge cycles. This passivation layer may have disadvantages, since, it increases the internal resistance of the element which causes a drop in voltage during use. SEI is not a major problem but it will become a problem at the end of cell life, reducing its ability to restore or accept ions (Bartlett *et al.*, 2017; Gao *et al.*, 2002).

MATERIALS AND METHODS

Lithium battery models

Simple model of a battery: The simplest and most common model consists of an ideal voltage source V_0 (no-load voltage) in series with an internal resistor. V_1 is the terminal voltage at the terminals of the accumulator (Xiong *et al.*, 2011; Yao *et al.*, 2013; Laadissi *et al.*, 2016) (Fig. 1).

In this simple model R_i and V_0 are considered constant. This model does not take into account the variation of the internal resistance of the accumulator as a function of the state of charge or the temperature. This model can be applied if we can neglect the dependence of the parameters of the state of charge and the temperature (Li *et al.*, 2017; Menard *et al.*, 2010; Shen and Li, 2017).

Thevenin model (first order): This model shown in Fig. 2 is often used. It consists of an ideal source U_{oc} , an internal Resistance R_0 , a Capacitor C_{th} which represents the polarization of the metal plates of the accumulator and an over-voltage Resistor R_{th} which is due to the contact of the plates with the electrolyte. In this model, all elements of the equivalent circuit are assumed to be constant and different in charge and discharge. But in reality these parameters also vary depending on the state of charge and the discharge rate:

$$U_{th} = \frac{U_{th}}{R_{th}C_{th}} + I_L \frac{1}{C_{th}} \quad (1)$$

$$U_L = U_{oc} - U_{th} - I_L R_0 \quad (2)$$

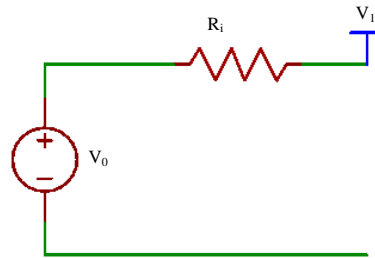

Fig. 1: Simple Model of a battery

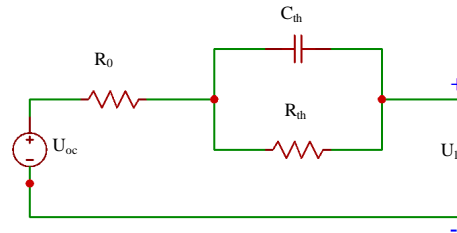

Fig. 2: Thevenin model (first order)

Thevenin model (second order): This model is represented by the following diagram: This model is characterized by the following Eq. 3-5:

$$\dot{U}_{pa} = \frac{dU_{pa}}{dt} = -\frac{U_{pa}}{R_{pa}C_{pa}} + i_L \frac{1}{C_{pa}} \quad (3)$$

$$\dot{U}_{pc} = \frac{dU_{pc}}{dt} = -\frac{U_{pc}}{R_{pc}C_{pc}} + i_L \frac{1}{C_{pc}} \quad (4)$$

The model above, gives the evolution of the voltage (U_L) the transient response related to the phenomenon of the double layer of electric polarization and the dynamic polarization. The two networks ($R_{pa}, C_{pa}, R_{pc}, C_{pc}$) make the assembly react to two different time constants, τ_{pa} (fast) and τ_{pc} (slow). It consists of an ideal source U_{oc} of open circuit voltage, Ohmic Resistance R_0 and two polarization Resistors, R_{pa} and R_{pc} which successively represent the resistance of the electrochemical polarization and the concentration polarization resistance and two Capacitors C_{pa} and C_{pc} which respectively, represent the electrochemical polarization capacity and the concentration capacity.

In the context of the development of estimation parameter algorithms and the necessary simulations, modeling by equivalent electrical circuits has been chosen, thanks to their precision and ability to reproduce the phenomena that dominate the operation of accumulators as well as to describe the dynamic behavior of the battery.

The most used model is Thevenin first order Fig. 2, thanks to the simplicity of implementation, this simplicity has the price of the reduction of precision because the

elements of the model are considered constant which is not true in reality as they vary depending on the state of charge, the temperature and the charging and discharging cycle.

To solve the problem of precision, the second order model of Thevenin, Fig. 3 was chosen this model which brings to the evolution of the voltage U_L , the transient response related to the phenomenon of the double layer of electric polarization and dynamic polarization. The two networks (E_{tp} , R_0 , R_{pa} , C_{pa} , R_{pc} , C_{pc}) make the set react to two different time constants, τ_{pa} (fast) and τ_{pc} (slow).

In this study, we considered that the components of this model only depend on the state of charge, we neglected the effect of the temperature and the cycle of charge and discharge.

To model the variation of the battery components (E_{tp} , R_0 , R_{pa} , C_{pa} , R_{pc} , C_{pc}) according to the SOC, we used under MATLAB, look-up tables which correspond to each value of SOC, given values of (E_{tp} , R_0 , R_{pa} , C_{pa} , R_{pc} , C_{pc}). A step of 0.05 (5%) was considered for SOC variation.

Due to the dependency of the parameters to the state of charge, the use of Simscape library resistors and capacity for the model is not optimal, new components need to be created that model this dependency which is possible using the Simscape language that allows us to create any component (electrical, mechanical, hydraulic, ...) which can vary in a non-linear way and also depend on one or more input variables which is our case. Using the Simscape language, the model given in Fig. 4 has been realized, the components of which vary according to the SOC which is the output of the block that models the open-circuit voltage of which the Columbus count method was used. Metric to calculate the state of charge which is in turn injected into the blocks of resistances and capabilities.

Using the Simscape language we have realized the model given in Fig. 4, the components vary according to the SOC which is the output of the block which models the voltage in open circuit, we used the method of counting Columbus to compute the state of charge which is injected into the blocks of resistors and capacitors.

It is this model that, we use during all simulations under MATLAB, now, we must identify the internal parameters of this model.

Parameters identification: The Levenberg-Marquardt algorithm was chosen for parameters identification, thanks to its high performance and its simplicity of implementation (Yu *et al.*, 2017; Zhang *et al.*, 2017; Lei *et al.*, 2017; Huang *et al.*, 2017).

The Levenberg-Marquardt algorithm is similar to one of the least-squares nonlinear algorithms that seeks to minimize the function 6. The principle of this algorithm is as follows:

Algorithm 1; Least-squares nonlinear algorithm:

Input: F differentiable function, x_0 starting point, $\epsilon > 0$ precision required
Output: an approximation of the solution of the least squares problem

$$\text{Min}(r(x)) = \frac{1}{2} \sum_{i=1}^m (Zr(i) - Zest(i))^2 = \sum_{i=1}^m f_i(x)^2 \quad (5)$$

- 1: $K = 0$
- 2: As long as stop criterion is not reached:
 - a: Calculation of a search direction, calculate a solution of d_k

$$JF(x_k)^T JF(x_k) + \lambda I = - JF(x_k)^T F(x_k) \quad (6)$$

- b: $x_{k+1} = x_k + d_k$
 - c: Update of the λ parameter
 - d: $k = k + 1$
- 3: Return x_k

The parameter $\lambda \geq 0$ can be chosen fixed or heuristically adjusted: increased or decreased by a factor depending on the quality of the step proposed.

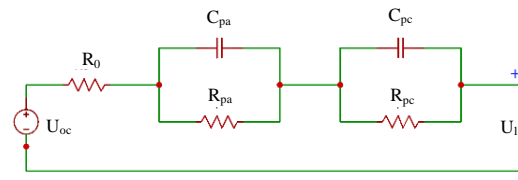

Fig. 3: Thevenin model (second order)

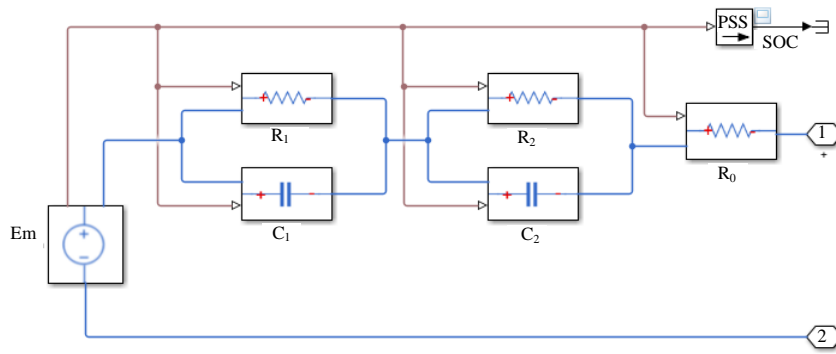

Fig. 4: Second order Thevenin Model with variable components

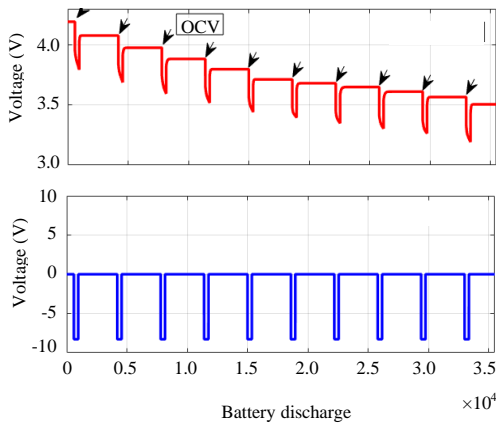

Fig. 5: Battery discharge curve; a) Voltage discharge curve and b) Current discharge pulse

Experimental data: First, we will use the discharge curve to extract the open circuit voltage U_{oc} as well as an approximation of the values of the internal Resistance of the battery (R_0) in order to impose them on the Levenberg-Marquardt algorithm to minimize the identification time.

A commercial Lithium-ion battery (3.8 V, 16 Ah), having an initial state of charge of 100% is completely discharged with current pulses of value $-C/2$ (-8A). This discharge is decomposed in several intervals, each interval consists of a duration of application of the current is equal to 6 min, followed by a relaxation time which lasts 1 h. This relaxation time allows the convergence of the voltage of the battery to the value of OCV corresponding to the current state of charge of the battery.

Values of voltages, currents and times are recorded throughout the battery discharge process. These values will be used later as data for the parameter identification method.

Open circuit voltage approximation: The open circuit voltage which corresponds to each state of charge at each interval is the last voltage measured before the application of a new current pulse. In other words, it is the voltage that reaches the battery at the end of the relaxation phase. The following Fig. 5 shows the open-circuit voltage values U_{oc} of each interval on the voltage curve during the discharge.

Approximation of R_0 : In this study, we are looking for an approximation of the values of the internal resistance R_0 of the battery. When applying the current, the battery

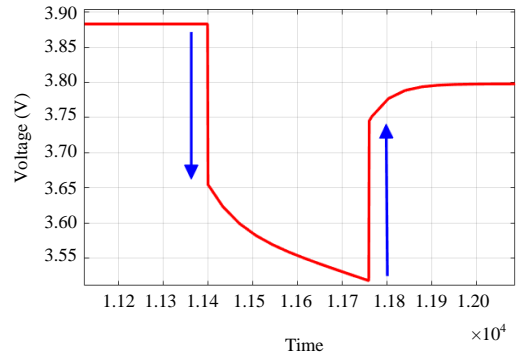

Fig. 6: Voltage drop due to R_0

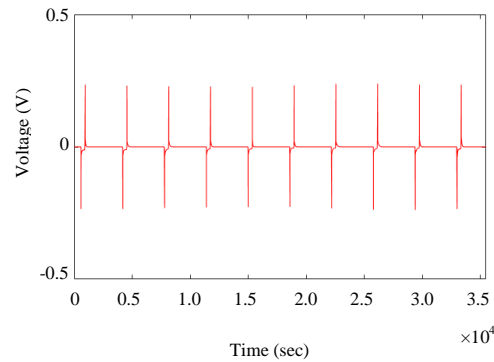

Fig. 7: Voltage drop for all intervals

voltage has an instantaneous drop due to R_0 , negative in the case of discharge (current <0) (Fig. 6). This fall disappears in the relaxation phase because of the absence of the current. By detecting this voltage difference, R_0 is obtained by dividing the voltage by the value of the applied current.

To calculate this voltage drop, we use, under MATLAB, the voltage gradient vector shown in Fig. 7. The negative and positive voltage peaks represent this instantaneous voltage variation at the beginning and at the end of the current pulse interval.

The value of the voltage drop obtained will be divided by the value of the current applied and we obtain an approximation of the resistance R_0 which corresponds to the value of SOC in this interval.

By carrying out the same study on all the intervals, we deduce an approximation of the value of R_0 corresponding to each interval (5% of state of charge).

RESULTS AND DISCUSSION

The parameter identification (E_{mp} , R_0 , R_{pa} , C_{pa} , R_{pc} , C_{pc}) was performed using the optimization MATLAB tool (Control and estimation tools manager) in which is

integrated the Levenberg-Marquardt algorithm: The interface (Control and estimation tools manager) takes as parameters:

- The discharge current
- Voltage at the battery terminals during discharge
- The capacity of the battery
- The initial values of the lock-up tables of $E_m, R_0, R_{pa}, C_{pa}, R_{pc}, C_{pc}$.

This algorithm gives as output parameters the new identified values of ($E_m, R_0, R_{pa}, C_{pa}, R_{pc}, C_{pc}$) such that the model best reproduces the dynamics of the battery.

The voltage variation across the battery as well as the discharge current values are obtained by discharge and charge tests by pulses on a commercial power battery of 16 Ah and rated voltage 3.8 V. As part of this procedure, the battery was fully charged, then subjected to 10-C/2 discharge pulses interspersed with a resting phase of one hour until the cell was completely discharged. Then, the battery was charged with 10 C/2 charging pulses interspersed with a one-hour resting phase until the battery was fully charged.

The initial values of the lock-up tables of $R_{pa}, C_{pa}, R_{pc}, C_{pc}$ are taken intuitively. The results obtained are as follows in Fig. 8:

At the beginning of the identification the response of our model and the experimental data of the battery are different which is normal because the initial parameters are chosen intuitively and as the identification progresses, these values change in order to make the estimated curve (response of our model) similar to that of the battery.

Identification result: Note from Fig. 9 that the two responses (estimated and measured) are similar with an error <0.5% which means that the set of parameters that minimize the term 6 are those found by the identification process. The variation of the parameters ($E_m, R_0, R_{pa}, C_{pa}, R_{pc}, C_{pc}$) is given by Fig. 10:

As shown in the figures, the values of the internal parameters of the battery vary according to the State of Charge (SOC), Fig. 10 shows the variation of internal Resistances (R_0), we note that at the beginning of the discharge (area between 100% and 85% of the state of charge) the value of R_0 increases, to simulate the voltage drop seen at the output of the battery. During the same phase the values of the Capacitances C_{pa} and C_{pc} vary to simulate the exponential decay of the voltage, Fig. 10 also show that from 0% of the SOC up to 15%, we notice that

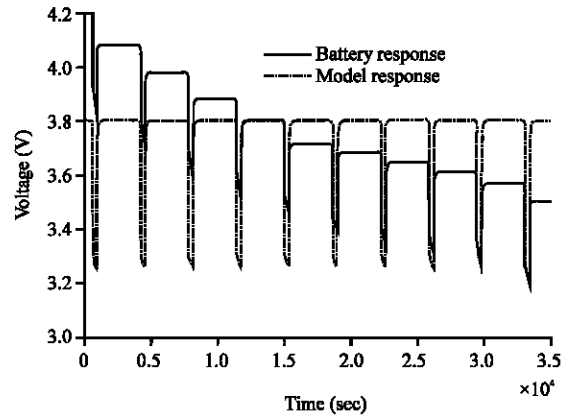

Fig. 8: Measured vs. estimated response

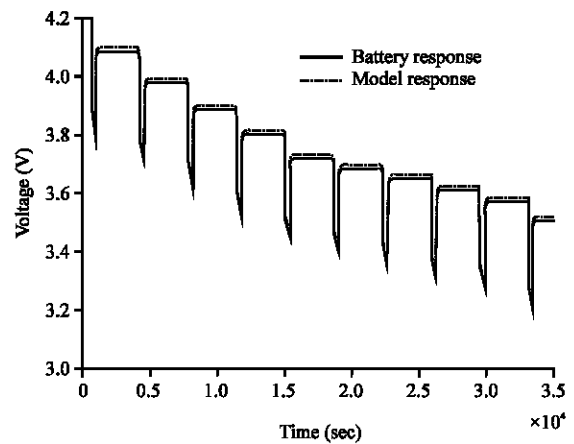

Fig. 9: Measured vs. estimated response after parameters identification

the values of the Resistances (R_0, R_{pa}, R_{pc}) change dramatically which verifies the sudden voltage drop at the output of the battery.

Validation of the model: An equivalent electrical circuit has been used to model the battery, the internal parameters of this model have been identified using the Levenberg-Marquardt algorithm.

For the validation of these parameters, the model is discharged by a succession of current pulses of amplitude -12 A in order to compare its response to that of the commercial battery for the same discharge current profile: discharge by a sequence of amplitude pulses -12 A

According to the two graphs Fig. 11 the responses of the model and that of the actual battery are almost similar which implies that the parameters obtained by the identification, model well the behavior of our battery in the transient and permanent regime which validates the parameters found and the model chosen.

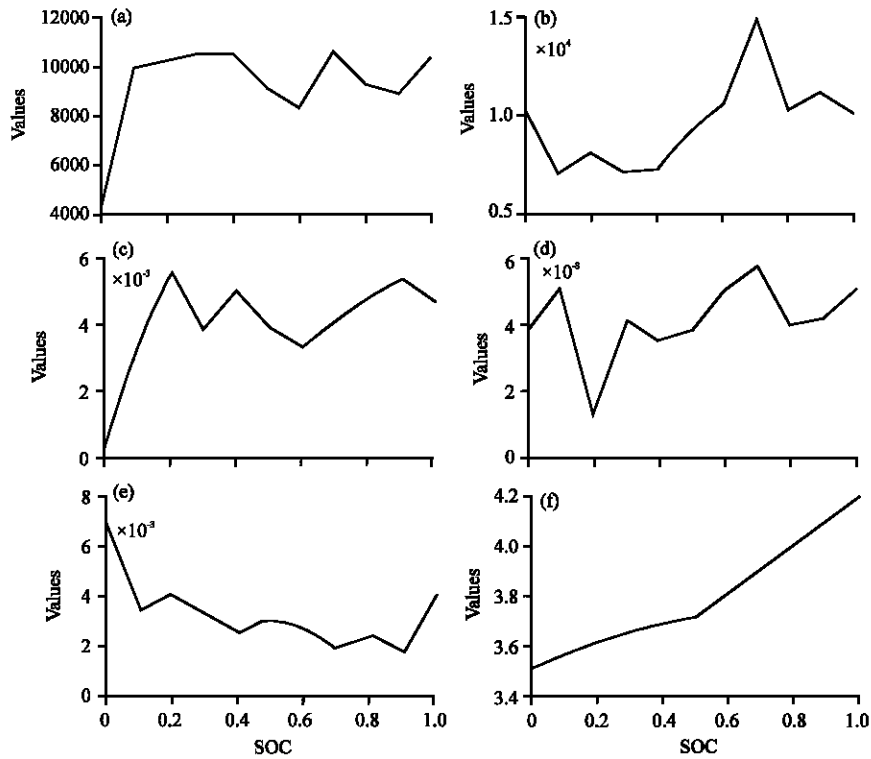

Fig. 10: Parameters variation according to the state of charge; a) $C_{pa}(F)$; b) $C_{pc}(F)$; c) $R_{pa}(\Omega)$; d) $R_{pc}(\Omega)$; e) $R_o(\Omega)$ and $E_m (v)$

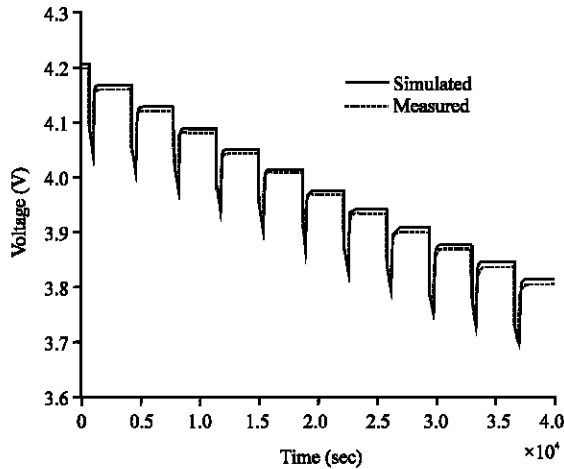

Fig. 11: Measured vs. estimated response for -12 A pulses

CONCLUSION

After having specified the different phenomena that take place within the lithium-ion battery an equivalent electrical model has been established using the Simscape MATLAB language. At the model level, the parameters are considered variable just according to the state of charge in order to simplify the study. The parameters of the chosen model were identified by the least-squares

**Levenberg-Marquardt algorithm. The model chosen and the parameters obtained were validated by different discharge current profiles by comparing the response of the model with that of the actual battery studied.

REFERENCES

- Bartlett, D., T. Herman and A. Klinkman, 2017. Business models for extracting more useful life from lithium ion battery systems. Master's Thesis, Duke University, Durham, North Carolina.
- Fotouhi, A., D.J. Auger, K. Propp and S. Longo, 2017. Electric vehicle battery parameter identification and SOC observability analysis: NiMH and Li-S case studies. IET. Power Electron., 10: 1289-1297.
- Gao, L., S. Liu and R.A. Dougal, 2002. Dynamic lithium-ion battery model for system simulation. IEEE. Trans. Com. Packag. Technol., 25: 495-505.
- Huang, C.S., T.W.S. Chow and M.Y. Chow, 2017. Li-ion battery parameter identification with low pass filter for measurement noise rejection. Proceedings of the 2017 IEEE 26th International Symposium on Industrial Electronics (ISIE), June 19-21, 2017, IEEE, Edinburgh, UK., ISBN:978-1-5090-1413-2, pp: 2075-2080.

- Laadissi, E.M., E.F. Anas and M. Zazi, 2016. Nonlinear black box modeling of a lead acid battery using hammerstein-wiener model. *J. Theor. Appl. Inf. Technol.*, 89: 476-480.
- Lei, B., G. Xu, M. Feng, F. Van der Heijden and Y. Zou *et al.*, 2017. Classification, Parameter Estimation and State Estimation: An Engineering Approach using MATLAB. 2nd Edn., John Wiley & Sons, Hoboken, New Jersey, USA., ISBN:9781119152453, Pages: 480.
- Li, Y., D.M. Vilathgamuwa, T.W. Farrell, S.S. Choi and N.T. Tran, 2017. An equivalent circuit model of Li-ion battery based on electrochemical principles used in grid-connected energy storage applications. Proceedings of the 2017 IEEE 3rd International Conference on Future Energy Electronics and ECCE Asia (IFEEC 2017-ECCE Asia), June 3-7, 2017, IEEE, Kaohsiung, Taiwan, ISBN:978-1-5090-5158-8, pp: 959-964.
- Lu, L., X. Han, J. Li, J. Hua and M. Ouyang, 2013. A review on the key issues for lithium-ion battery management in electric vehicles. *J. Power Sour.*, 226: 272-288.
- Menard, L., G. Fontes and S. Astier, 2010. Dynamic energy model of a lithium-ion battery. *Math. Comput. Simul.*, 81: 327-339.
- Shen, W.J. and H.X. Li, 2017. Multi-scale parameter identification of lithium-ion battery electric models using a PSO-LM algorithm. *Energies*, 10: 1-18.
- Xiong, R., H. He, H. Guo and Y. Ding, 2011. Modeling for lithium-ion battery used in electric vehicles. *Proc. Eng.*, 15: 2869-2874.
- Yao, L.W., J.A. Aziz, P.Y. Kong and N.R.N. Idris, 2013. Modeling of lithium-ion battery using MATLAB/simulink. Proceedings of the IEEE 39th International Annual Conference on Industrial Electronics Society (IECON 2013), November 10-13, 2013, IEEE, Vienna, Austria, ISBN:978-1-4799-0224-8, pp: 1729-1734.
- Yu, Z., L. Xiao, H. Li, X. Zhu and R. Huai, 2017. Model parameter identification for lithium batteries using the coevolutionary particle swarm optimization method. *IEEE. Trans. Ind. Electron.*, 64: 5690-5700.
- Zhang, Y., R. Xiong, H. He and W. Shen, 2017. A lithium-ion battery pack state of charge and state of energy estimation algorithms using a hardware-in-the-loop validation. *IEEE. Trans. Power Electron.*, 32: 4421-4431.