

## Review on Influence of Infilled on the Seismic Behavior of Frame Structures

Sanaa Elmalyh, Azzeddine Bouyahyaoui and Taoufik Cherradi  
Department of Civil Engineering, Mohammadia School of Engineers,  
Mohammed V University of Rabat, Morocco

---

**Abstract:** Earthquakes prove that infill walls have a negative significant effect on concrete frame, e.g., soft-storey, short column due to partial infills, torsional effects due to irregular and unsystematic placement infills and out-of-plane collapse. However, their influence still not taken in consideration, therefore, it is very important to define the behavior of the infill panels in the seismic response. Steel or reinforced concrete frames are currently used in buildings with infill panels which are generally ignored when analyzing the seismic effects, the fact that infill panels were not covered in the design stage and also in analyzes had led to a significant damage, e.g.: Al-Hoceima in Morocco-L'Asnam in Algeria and Pam in Iran. The interaction between frames and masonry infill panels in the seismic analysis becomes imperative to avoid such damage, indeed, these infill panels are not considered as structural elements in structural analysis even if they have a significant contribution on the structures properties (stiffness, strength, ductility, energy dissipation capacity).

**Key words:** Infilled panels, ductility, reinforced concrete, frames, hysteretic behavior, base shear forces, seismic response, fundamental period

---

### INTRODUCTION

Nonlinear studies on structures ignore the strength and stiffness of infill panels which considered as non-structural elements even if they have a considerable effect on the seismic behavior of structures, this result is due to their important stiffness and strength that alter the overall resistance of structures during an earthquake. The influence of infill panels has been defined by many researchers. After earthquakes, many cracks were observed in walls which have direct effects on the seismic response of reinforced concrete frames, furthermore, they can affect the seismic behavior of frames. Many researchers concluded that the infill panels increase the initial stiffness of reinforced concrete frames, moreover, most of the seismic shear forces are attracted by infilled walls. So, it becomes crucial to define the influence of infill walls on frames. The aim of this study is to review the approach used for the analysis of infilled frame structures and to present a literature review and give a summary of different researches, especially, those working on evaluating the diverse results associated with modeling different types of structures, reasons of fissure appearance in structural element caused by infill walls, the evaluation of results and the study of the effect of dynamic load on structures. Our research will focus on the modeling of panels in order to predict a more realistic response of buildings to seismic actions. This research

will include an experimental part and a numerical part, resulting in the modeling of masonry panels. This study compares and review analysis and different results related to infilled frames.

### MATERIALS AND METHODS

**General description:** Micro and macro-models had been proposed by researchers to define the behavior of infill panels and frames subjected to seismic forces. Different results observed from the experiments on the two types of models. Table 1 presents a summary of different type of damages which occurs during seismic loading in structural and non-structural elements.

It was observed that the presence of infill masonry walls in structures can have a positive contribution to the lateral stiffness and strength of the structure but they could have disadvantageous effects which depend on a direct way on the type of infill provisions (partial infilled frames, fully infilled frames, bare frame without infill, infilled frames with opening) that can affect the seismic response of structures. It was observed that structures with partial infill walls can cause captive columns, also, the horizontal structural elements, affect the height of a column and create short columns that cause remarkable damage in structures, consequently, the behavior of columns changes.

Table 1: Different type of damages of different elements subjected to seismic force

| Seismic response type of damage | Infill pannel                                            | Bar frame                                  | Infill pannel and frame interaction |
|---------------------------------|----------------------------------------------------------|--------------------------------------------|-------------------------------------|
| 1                               | Flexure                                                  | No damages                                 | Not separated                       |
| 2                               | Mid height crack                                         | Plastic hinges and cracks in frame members | Not separated                       |
| 3                               | Diagonal cracks                                          | Plastic hinges and cracks in frame members | Not separated                       |
| 4                               | Horizontal slip                                          | Plastic hinges and cracks in frame members | Not separated                       |
| 5                               | Diagonal cracks and crushing in the two diagonal corners | Plastic hinges                             | Partially separated                 |

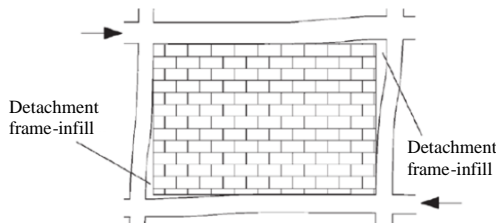

Fig. 1: Detachment frame-infill

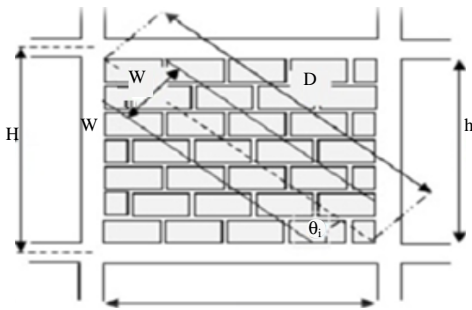

Fig. 2: Parameters characterizing the equivalent strut

**Equivalent diagonal Strut Model:** Researchers have proposed several models for treating infill walls, after (Ghosh and Amde, 2002) analysis, Holmes (1961) has used a steel frame, the results of many experiments have proven that when infilled frames subjected to cyclic or dynamic loading the infill panels were detached from the frame (Fig. 1 and 2).

An experiment on square infill with lateral and diagonal loads has been done by Smith (1962a, b); He developed the model of Holmes and proposed a numerical procedure to determine geometrical grandeur. Also, he did many tests, to define the width of the equivalent strut.

When the infill walls in frames subjected to lateral loads, the effect of the infill panels is equivalent to diagonal strut. Therefore, the researchers modeled infill panels by a diagonal strut approach. The simplified models have been proposed as solution for complicated study of structures. The diagonal strut model with their simple geometry, presented in a direct way the effect of infill panels but it couldn't define the interaction between infill panels and bar frames. As a consequence, the shear forces, the bending moments, the plastic hinges, the frame crack don't present the real influence of infill panels on bar frames. Holmes proposed to replace the infill walls by

two equivalent diagonal bars with the same material as that of the frame and which have a width equal to 1/3 of the diagonal length:

$$W = \frac{d_m}{3}$$

Many results were based on Smith (1962a, b, 1967), Smith and Carter (1969) method. Which use the same parameters but with different calibrations depending on the country. The general relation of the thickness of the bar modeling the infill walls presented by the following equations:

$$w = \alpha \times \beta^{\gamma} D$$

With:

$$\beta = \lambda \times h$$

And:

$$\lambda = \left( \frac{E_m t \sin 2\theta}{4E_c I_c h} \right)^{\frac{1}{4}}$$

The following formulas has ben proposed by Mainstone (1971) to calculate the width of the bars:

$$w = 0.175 \times \beta^{-0.4} \times D$$

Based on analytical and experimental data Liauw and Kwan (1984) suggested the following approximation:

$$w = 0.16 \lambda_h^{-0.3} d_m$$

After Dawe and Seah (1989) had calculated the diagonal width by the following equations:

$$w = \frac{\pi}{1.5 \times \lambda_h} \cos \theta + \frac{\pi}{1.5 \times \lambda_t} \sin \theta$$

And:

$$\lambda_t = \left( \frac{E_m \times t_i \times \sin(2\theta)}{4 \times E_c \times I_b \times h_i} \right)^{\frac{1}{4}}$$

$$\lambda_h = \left( \frac{E_m \times t_i \times \sin(2\theta)}{4 \times E_c \times I_b \times h_i} \right)^{\frac{1}{4}}$$

The width of the diagonal presented by Durrani and Luo (1994):

$$w = \gamma \times \sin(2\theta) \times D$$

And:

$$\gamma = 0.32 \times \sqrt{\sin(2\theta)} \times \left( \frac{h^4 \times E_m \times t_i}{m \times E_c \times I_c \times h_i} \right)^{-0.1}$$

$$m = 6 \times \left( 1 + \frac{6 \times E_b \times I_b \times h}{\pi \times E_c \times I_c \times L} \right)$$

The Moroccan Model based on Smith (1996), results and the experimental tests carried out by Elouali gives values of the coefficients  $\alpha$  and  $\lambda$  to use the simplified model with diagonal, the thickness with the following formulas must be calculated:

$$w = 0.135 \times \beta^{0.4} \times D$$

D is the length of the strut,  $E_c$ ,  $I_c$  and H are the elastic modulus, the modulus of inertia and the height of the column panel respectively.  $\theta$ , t,  $H_i$  are the angle defining diagonal strut with the horizontal, the thickness and the height of the infill panel, respectively. The elastic in-plane stiffness of a masonry infill panel is represented with a compression strut of width W. The initial lateral stiffness  $K_i$  of a diagonal strut is given by the following expression:

$$K_i = \frac{E_i w t \cos^2 \theta}{D}$$

A detailed study had been performed by El-Dakhkhni on the model of three bars which had been developed. The bar in the middle attached to the columns extremities, for the two lateral bars, they are connected at the plastic hinges levels. When the central bar crashed, the horizontal force was taken by the other eccentric two bars, causing a valuable shear force in the bare frame at the plastic hinges. The aim of the three bares model was to define the influence of masonry walls on beams and columns, therefore, the investigations carried out by El-Dkhakhni Fig. 3 have indicated the effect of masonry walls.

From the above results, ductility can be used for spectrum analysis response. However, for the best results, the ductility should be generated with a hysteretic model which reflects the behavior of infilled frames.

**Response of diverse type of strut models:** A model of 2.5 m high masonry panel with a length of 3.6 or 5.0 m and the elastic modulus for masonry of 2500 or 10,000 MPa, dimensions of frame members were 200×200 mm and the elastic modulus of concrete was 25000 MPa had been

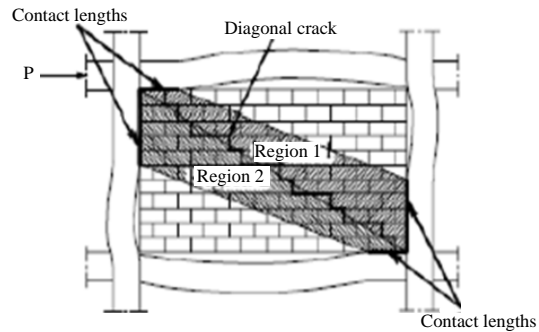

Fig. 3: The two diagonals behavior regions

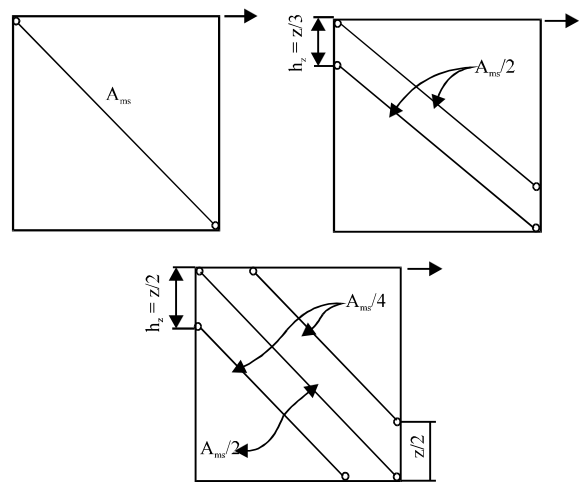

Fig. 4: Different strut models considered: a) Model A; b) Model B and c) Model C

used by Crisafulli (1997). The model was subjected to static lateral loading assuming the linear behavior. The stiffness of the infilled frame was similar for Model B and C. For multi strut-models were presented in the Model C in this case the stiffness depends on the distance  $h_p$  when it increases the stiffness of the infilled frame reduces (Fig. 4).

Figure 5 compared bending moment diagrams obtained from the test on aforementioned models. The bending moment was underestimated in the mode A for the reason that the lateral forces are resisted by truss mechanism. For the Model B leads to a much larger value than those corresponding to the finite element model but the best approximation was obtained from Model C.

Based on the experimental results, Zarnic and Tomazevic (1988) suggested the model in Fig. 6, this model is the result of the disruption caused by the devices utilized to apply the lateral and vertical loads in the corners of bare frames, this is why in the suggested model the upper part of the diagonal strut is not associated to the beam column joint.

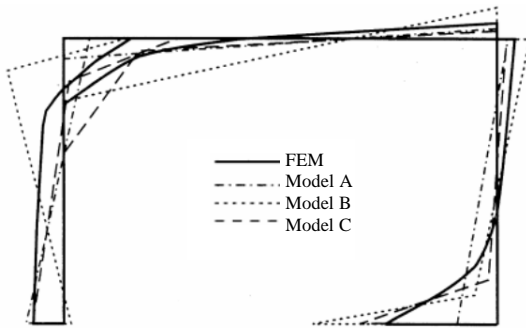

Fig. 5: Comparison of the bending moments diagrams of different strut models

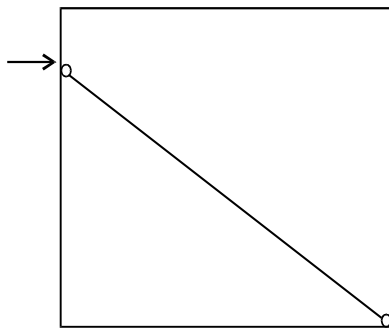

Fig. 6: Modification of the diagonal strut

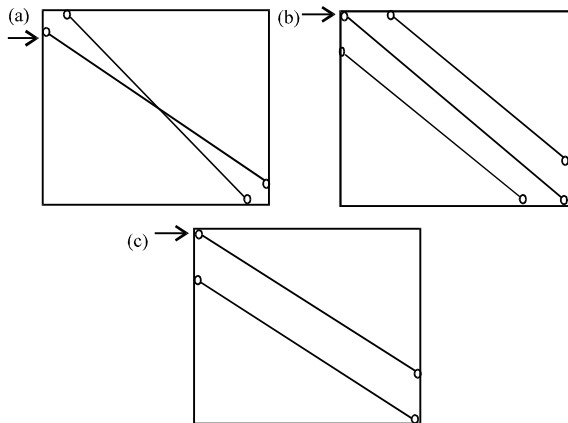

Fig. 7a-c: Multiple struts models

For more accurate and closer presentation of infill wall behavior in the frame, multiple struts models had been proposed by Chrysostomou (1991) and Crisafulli (1997) (Fig. 7).

## RESULTS AND DISCUSSION

**Stiffness strength ductility and energy dissipation:** Nonlinear structural analysis was carried out on different

models of various configurations with different patterns of infill walls to define the seismic response of the structural systems; The pushover curves and the effect of irregular configuration of infill masonry walls on the performance of the structure were studied. For those analyses the SAP 2000 analysis, commercial software used. Due to pushover curves, the relative storey displacement, storey displacement and maximum plastic rotations are determined. The analysis of the results shows the effects of irregularities on the comportment of structure under earthquake. The irregular distribution of masonry infill walls in elevation provoked an unacceptably elastic displacement in the soft storey frame. The analysis results show that the presence of infill masonry walls affects considerably and positively the seismic comportment of the structure also, negative effects, including soft storey phenomenon were caused by the irregular vertical distribution (Korkmaz *et al.*, 2007). Also, Murty and Jain (2000), worded to prove the positive effects of masonry walls on the bare frame.

Diverse types of infilled bars were used to evaluate the behavior of bare frames; Infill walls had been tested under different loads to deduce the influence of infilled on the stiffness, strength and energy dissipation. Also, in India, the reinforced concrete frame buildings with brick masonry infills presented a good performance even if the most of the buildings which had a uniform configuration and small panel size were not designed for seismic response (Jain *et al.*, 1997).

According to Murty and Nagar (1996), the initial stiffness and strength of infill panels modify considerably the general behavior of the frame, indeed, a high energy dissipation caused by progressive cracking in infill panels. The experimental results of the clay brick masonry show a considerable large of scatter. Also, the presence of the infill in the frames affects the displacement of the bare frames because the maximum bare frame displacement was 20 mm when the infilled frame maximum displacement was 4 mm and the behavior of the frame still almost elastic even if the infill walls were cracked. Afterward, two types of infill panels which were made from hollow concrete blocks and hollow clay tile blocks, realized by Elouali have been tested by using a quasi-static alternate loading. Loads were increased to crack masonry infill panel without yielding the steel frame. The initial stiffness for small strains increases, it can reach 7 times that of bare frame. The experimental data show that after the first shear cracking, stiffness of the infill frame is higher than that of the bare frame even after the collapse of the masonry panel as illustrated in Fig. 8. As shown in the Fig. 9 and 10, the infill panels increase the stiffness of the infilled bare frame.

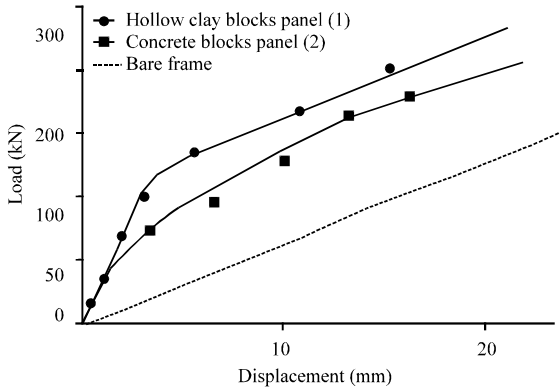

Fig. 8: Experimental strength envelopes vs. displacement curves

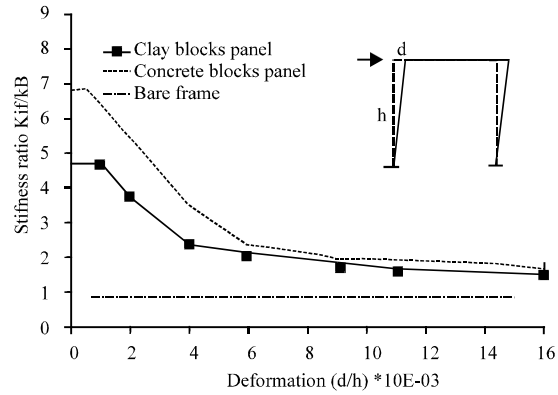

Fig. 10: Degradation of panel stiffness ( $K_b$  stiffness of bare frame,  $K_{if}$  stiffness of infilled frame)

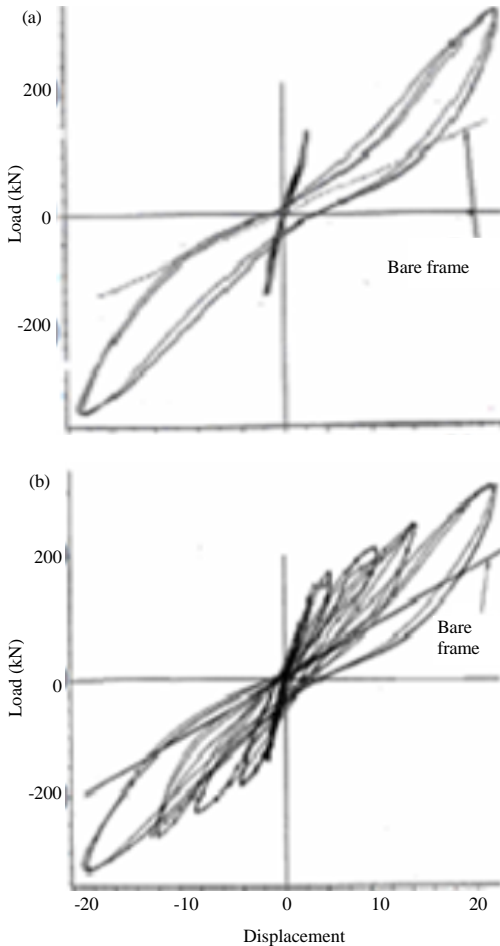

Fig. 9a, b: Load versus displacement curves

According to Elouali the presence of the infill panels increase the strength of the frame, it can reach 1.9 times that of the bare frame Fig. 10, even after the collapse of panels, the strength of the infill frame still

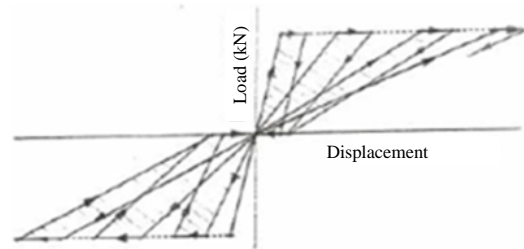

Fig. 11: Hysteretic model of clay blocks; Hollow clay blocks

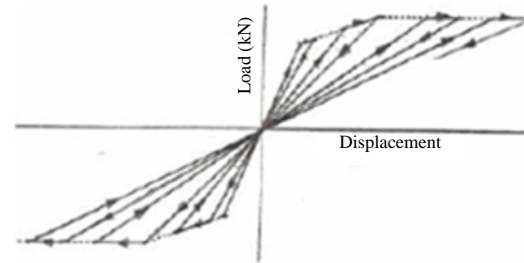

Fig. 12: Hysteretic model of concrete blocks; Hollow concrete blocks

without any reduction even after degradation of the infill panel. Furthermore, a hysteretic model for diagonal strut for each type of infill was proposed from the test results to simulate the initial stiffness, strength and degradation (Fig. 11 and 12).

Also, Klinger and Bertero (1978) had proposed the first diagonal equivalent model with hysteretic behavior. This model contains two equivalent diagonals connecting to the column and the beam to simulate the softening in the masonry panel and the stiffness degradation observed under cyclic loading. The axial stiffness of the equivalent strut presented by the following equation:

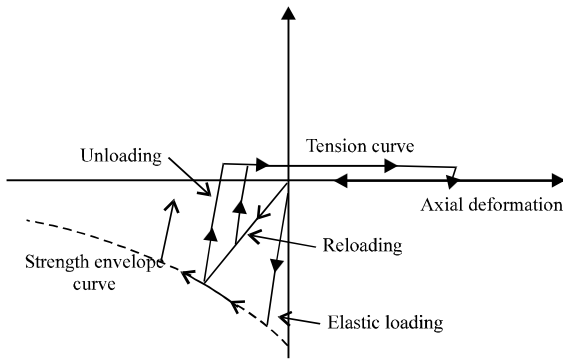

Fig. 13: Hysteretic behavior of the equivalent strut proposed by Klingner and Bertro (1976)

$$K_1 = \frac{E_w A_p}{l_p} = \frac{E_w (t_w) (d_p)}{\Sigma l_p}$$

Also, the peak strength of the equivalent strut was proposed by using the failure compression stress  $f_{kd}$ :

$$R_p = A_p f_{kd} = t_w d_p f_{kd}$$

Where:

$E_w$  = Young's modulus of the masonry

$l_p$  = The length of the equivalent strut which is calculated by  $l_p = \sqrt{h_w^2 + l_w^2}$

$d_p$  = The width of equivalent strut deduced by Mainstone and Weeks (1970)

Moreover, three hysteretic models had been developed by Klingner and Bertro (1976) to analyze the characteristics of the behavior of the equivalent diagonal strut Fig. 13 present the characteristic of the third model. Also, the strength envelope had been utilized for the nonlinear static analysis to define the influence of strength degradation.

Doudoumis and Mitsopoulou (1986) had proposed a hysteretic model (Fig. 14) which was developed for non-integral infilled frames, a gap developed between the masonry panel and the bare frame. The strength degradation was presented and the behavior of the structure had been precisely described on the hysteresis model.

Also, the relation between the force and the displacement was presented by Andreaus *et al.* (1985) in Fig. 15 that define the mechanical behavior of the equivalent diagonal struts. The strength degradation related to the strength of the equivalent strut which begin when the strength of the equivalent strut had been reached.

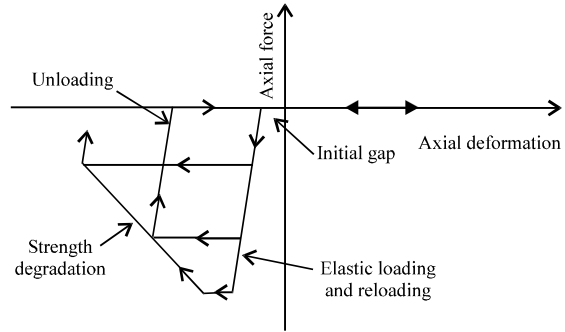

Fig. 14: Hysteretic model presented by Doudoumis and Mitsopoulou (1986)

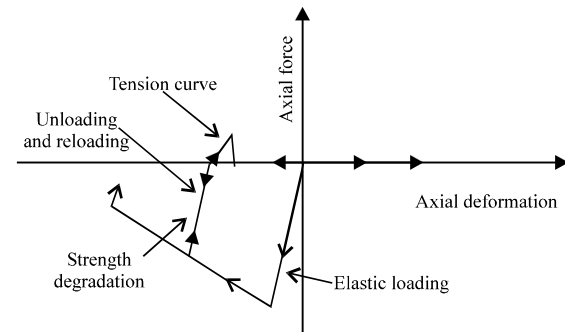

Fig. 15: Hysteretic model proposed by Andreaus *et al.* (1985)

For the numerical investigation, it has been based on the experimental results to determine the effect of infill panels on the overall seismic response of structures as a consequence, the fundamental periods of the structures reduces because of the presence of infill panels, moreover, the horizontal base shear forces increase when the fundamental period decreases. The expression used for dimension the equivalent diagonal strut was developed by Smith (1996). The equivalent diagonal used to replace the confined panels change the rigid frame into trussed frame, so, the frame will resist to lateral loads also, the flexural effects will decrease significantly.

To have an analytical explanation of the almost linear performance of a building during the earthquake, a 3-dimension nonlinear analysis (time history analyses) of a beam telephone center reinforced concrete building with divers type of infilled frame and bare frame, submit to the horizontal components of the recorded strong motion were applied, thus, the response simulations were carried out for those frames. Through the damage evaluation of the post-earthquake, almost no residual deformations or cracks remarked in the structural elements of the building.

So, an approach was developed for modeling infill walls with or without openings. A significant effect of infill walls was observed on the structural response of the building. The comparison of analysis results with the damage and residual cracks observed on the masonry panels. It could be concluded that the building without infill panels could suffer from large nonlinear deformations and damage during an earthquake. The maximum overall storey drifts ratio of 0.8% was obtained for the ground floor of the building, which is less than a limit yielding a drift ratio of 1%. It was concluded that the presence of masonry infill walls is the principal cause of the nearly linear response of the Bam telephone center building during the earthquake.

The effect of different parameters on energy dissipation on a plastic hinge length and on general ductility of masonry shear walls, was studied by six fully grouted reinforced masonry walls which were tested under fully reversed cyclic lateral loading. Walls were designed to test ductile flexural failure. The experience purpose is to evaluate the influence of the amount and distribution of vertical reinforcement and the level of applied axial load on the lateral loading response and ductility of reinforced shear walls. For a cyclic loading, the results indicate a high ductile capability in the plastic hinge area and very little degradation of strength in the reinforced concrete masonry walls, a high level of energy dissipation was reached via. flexural yielding of the vertical reinforcement. All walls showed increasing hysteretic damping ratios with increase in displacement. The energy dissipation and displacement ductility were highly sensitive to increase in amount of vertical reinforcement but were less dependent on the level of applied axial stress. As a consequence, the plastic zone length decreases with the increase of the amount reinforcement. The results of this experience show that reinforced concrete masonry shear walls can be used in high intensity seismic zones (Shedid, 2006).

Furthermore, six full-scale walls were tested to failure under reversed cyclic lateral loading to analyze the influence of different amounts of flexural reinforcement, axial compression and the inelastic behavior of reinforced concrete walls. Results show that the top wall displacement in the beginning of yielding of the vertical reinforcement was extremely dependent on the amount of reinforcement and minimally affected by the level of axial compressive load. However, displacements of the walls were less sensitive to the amount of vertical reinforcement and to the level of axial compression in the maximum lateral loads. The displacement ductility was influenced by the amount of vertical reinforcement compared to the level of axial compression. Overall, as a consequence of

the test, the increase of ductility accompanied with relatively small strength degradation (about 20% of degradation in strength when the ductility achieves the maximum load), thus, when the vertical reinforcement ration and the axial compressive stress increase, the yield displacement increase. Furthermore, it was observed that all the test walls (with an aspect ratio of 2.0%) reached their maximum capacity at a top displacement close to 30 mm (0.83% drift) regardless of the test parameters (Shedid *et al.*, 2008).

An in situ diagonal compression test on a masonry brick walls specimen with displacement control on two experimental layers had been made to establish the ductility post peak load and to evaluate the diverse mechanical behavior on those specimens, it was concluded that the original masonry and the same masonry injected with mortar have shown an increment of strength and ductility with a factor in the range (3-4) (Franchi *et al.*, 2014).

**Failure mode:** To diagnostic the interaction of building members many experimental tests had been performed to analyze and describe the response of infilled reinforced concrete frames. Therefore, eight-scale models subjected to cyclic lateral loading and in some cases, vertical loads carried out on masonry infilled frames were realized. Through these experimental tests, the interactions between the geometric, material properties of reinforced concrete frame resistance and the resistance mechanism and the failure modes were determined. Moreover, the influence of the resistance to lateral loads was described. After experimental tests, the response of masonry infilled reinforced concrete frames subjected to static lateral loads was studied as a consequence, five principal failure mechanisms of infilled frames had been observed (Fig. 16).

The mode A (flexural mode), appeared in a low load level, the infill and the framework like an integral flexural element, they are not separated. It's not the same case for the tall, slender frames which have a very low ratio of flexural reinforcement in the columns. An early yielding of the flexural steel provides in the windward columns which are submitted to an uplift force. Also, at a moderate load level, the infill panels are usually partially separate from the bounding frame and especially, this behavior appears when the infill panels are not securely attached to the frame and particularly in the case where the infill panels are considered as nonstructural elements (Fiorato *et al.*, 1970).

The mode B (Midheight crack), the failure mechanism, a horizontal sliding crack appeared in the middle height, of the infill panel which evolves into a short column

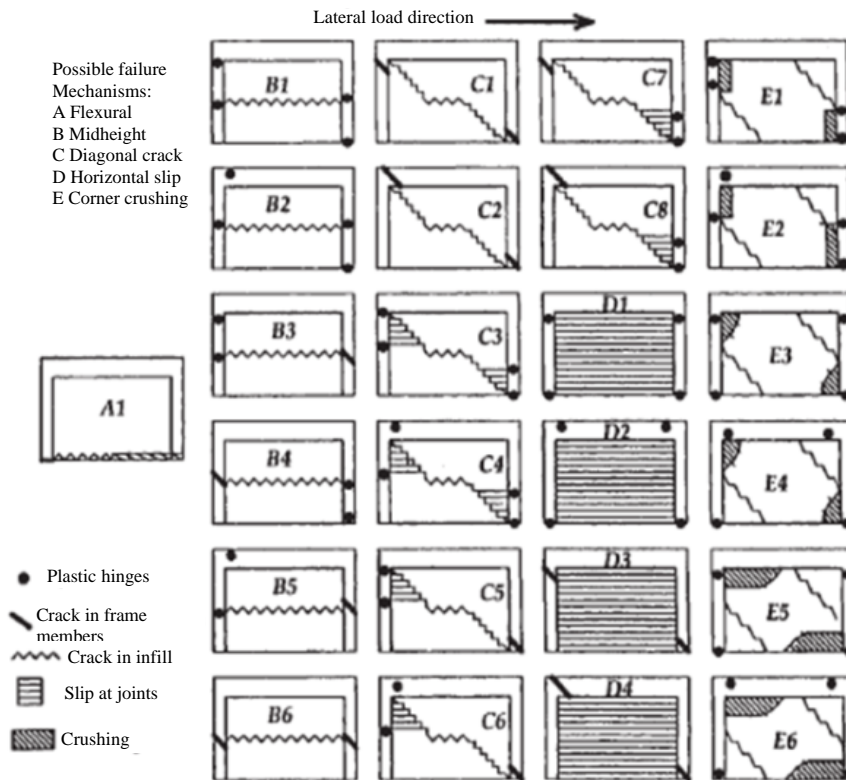

Fig. 16: Failure mechanisms of infilled frames

behavior. As a result, plastic hinge occurs in the middle height of frames (Fiorato *et al.*, 1970; Zarnic and Tomazevic, 1985).

The mode C (Diagonal crack), characterized by a diagonal cracks started from the loaded corner to the other one. As illustrated in Fig. 6, the diagonal cracks were accompanied by a horizontal crack in the midst of the infill panels which provide a corner crush and plastic hinge in the bare frames (Mehrabi *et al.*, 1994; Angel *et al.*, 1994; Mosalam *et al.*, 1997; Flanagan and Bennett, 1999).

The mode D (Horizontal slip) in this case a multiple slip appears at joints in the infill panels with weak mortar joints, hence, a ductile behavior comes with the possibility of eluding the brittle shear failure of the columns (Mehrabi *et al.*, 1994; Buonopane and White, 1999).

The mode E (Corner crushing), characterized by two diagonal parallel cracks usually jointed by corner crushing in the infill. Furthermore, the plastic hinge occurs in the middle of the frame. The crush can be produced in the center of the infill panels (Mehrabi *et al.*, 1994).

The limit analysis methods of Fiorato *et al.* (1970), Liauw and Kwan (1985) have been extended by

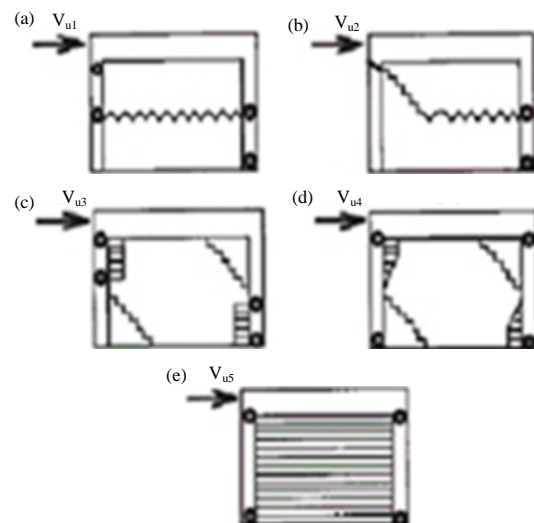

Fig. 17a-e: Most probable failure modes (Mehrabi and Shing, 1994)

Mehrabi *et al.* (1996) to obtain a more general approach that can be applied to the infilled masonry reinforced concrete. Figure 17 presents 5 failure mechanisms which had been chosen from Fig. 16 as the most probable failure mechanisms of infilled masonry reinforced



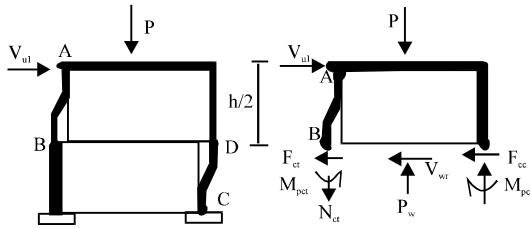

Fig. 18: Mechanism 1

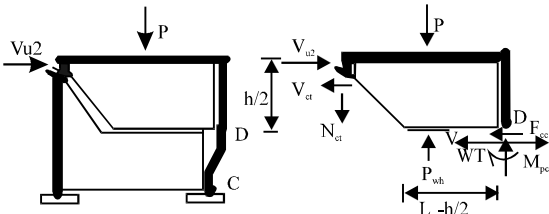

Fig. 19: Mechanism 2

concrete frames. The lateral resistance for the five failure mechanisms can be calculated by the equations proposed by Shing *et al.* (1992).

As shown in Fig. 18, the first failure mechanism is similar to the model of a knee-braced frame proposed by Fiorato *et al.* (1970) used to calculate the lateral resistance. Figure 18 shows that the lateral resistance is equivalent to the sum of the shear resistance of the wall and the shear force which is situated in the columns. Thus, the plastic hinges evolve in middle height, of the columns; Those hinges are often formed in a relatively large displacement. In this step the infill panel is considered cracked, indeed, the residual shear force of the cracked infill should be considered as the shear resistance of the infill panel.

The second failure mechanism illustrated in Fig. 19 is the development of the shear failure at one or more locations in the columns. The mechanism 2 causes a lateral resistance  $V_{U2}$  which is the sum of the ultimate shear resistance of the windward column, the shear force in the leeward column and the residual shear resistance along the horizontal crack in the wall.

In the third mechanism Fig. 20, the masonry is supposed reaching the crushing strength along the length at the wall-to-frame interface, furthermore, the plastic hinges are supposed have been developed in the columns near the beam to column joints and at B points in the columns. The mechanism is based on the plastic analysis method proposed by Liauw and Kwan (1982) which supposed that there is no significant shear transfer between the beam and the infill. Thus, the B points in the windward column, it's the place where the shear is zero and the moment is at its maximum.

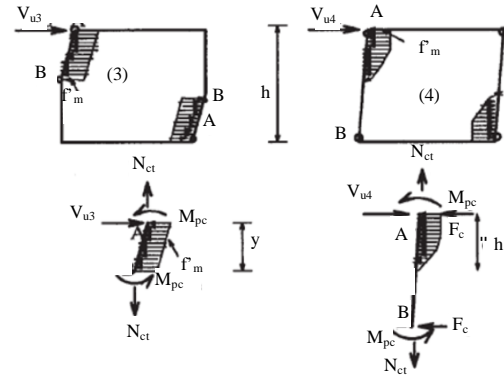

Fig. 20: Mechanism 3 and 4

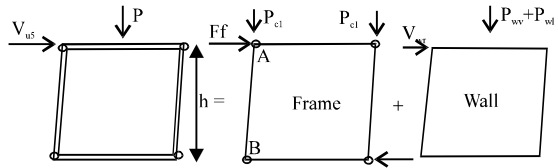

Fig. 21: Mechanism 5

In the 4th mechanism Fig. 20, the plastic hinges are considered have been developed at both ends of the columns, so there is no short column formed, this mechanism is based on the plastic analysis method proposed by Liauw and Kwan (1985). The masonry is considered to reach crushing at the compression corners. Furthermore, no valuable shear transfer is supposed between the infill panels and the beam. It is assumed that the contact stress at the wall-to column interface has a parabolic distribution along the contact length  $\alpha h$ . This distribution of the compressive stress is constructed from the assumption that the rotation of the column induces a linear variation of compressive strain in the masonry infill.

The fifth mechanism Fig. 21, two parallel systems formed by the frame and infill are assumed with the displacement compatibility at the compression corners. So, the sum of the residual shear resistance of the fractured wall and the flexural resistance of the frame is equal to the lateral resistance.

Thus, as concluded by Shing *et al.* (1992) that this approach provides better correlations with their experimental results. Hence, the analytical results show that the 5th mechanism is the dominant one for the specimens that had weak infills. In this mechanism, large slips along the bed-joints and the plastic hinges in the columns govern. But for the specimens that had strong infills, the results show that the mechanism 2 dominates.

This mechanism is governed by the diagonal/sliding shear failure of the infill and the shear failure of the windward column.

Other researchers had studied the criteria failure of unreinforced masonry submitted to in plane loading. An orthotropic failure surface of masonry panel submitted to biaxial stress state by applying a cubic tensor polynomial to describe the surface failure and to compare it with test data (Syrmakezis and Asteris, 2001).

A description of the formulation of failure and strength criterion for in plane loaded masonry of micro-structure has been studied by using a lower bound analysis to determine the stress fields constructed in masonry periodic cell critical load which is obtained as a solution to a constrained optimization problem (Kawa *et al.*, 2008).

**Finite element modelling:** To investigate the behavior of infilled frames, the finite element has been used. This approach becomes widely used for modeling and especially after the first finite element approach to analyze infilled frames developed by Mallick and Severn (1967).

Because of different characteristic of the infilled frames, diverse elements must be introduced in the model either in the bare frames or in the infilled panel or in the interaction between them. Finite element modeling had been widely used by researchers to investigate the behavior of infilled frames. The finite element advantage is the precise description of the influence of the interaction panel-frame, cracks and crushing. So, to achieve this objective, the interaction and the propriety of different element constitutive must be specified also the nonlinear comportment must be taken into consideration. As a consequence, the input data needed will facilitate the model analysis. Also, the composite behavior of infilled frames makes the analysis of structures not reflecting the nearest behavior of the infilled frames. Many factors participate to the nonlinear behavior of the infilled frames occurs from nonlinear properties of materials, like the stiffness, strength and ductility degradation which is related to infilled panel behavior, surrounding frame and the interaction between panel and frame. Different models of frames, infilled panels and panel-frame interfaces with finite element will be presented in this part.

**Infill panels modelling:** The infilled panels were ignored when analyzing the structure because of their neglected stiffness, strength and ductility when it's compared to the frame. Taking into account infill walls in mathematical modelling can produce results which are closer to the stiffness, ductility and strength of the structure. There are

many approaches for analyzing the infilled frames in the literature two types of models were suggested to idealize the composite structure, micro models that contain several elements that permit to take precisely into consideration the local effects and macro models.

In the infill panel, the mortar is weaker than the masonry as a consequence the failure of masonry caused the crushing and fracturing of masonry units and the mortar joints. Also, when the masonry is under compression the lateral expansion of the mortar provides a lateral tensile stress on the brick that cause a confining stress on the mortar which cause tensile splitting of the brick in a plane perpendicular to the bed joints. As a result of mortar and brick interaction, the stiffness and compressive strength of brick are higher than the masonry assembly which is higher than the results of the mortar (Hilsdorf, 1969).

Also, three different types of elements had been used by Liaum and Kwan (1982) to study the comportment of infilled frames submitted to monotonic loading. The infill panel modeled by triangular plane stress elements, the material was idealized in tension as a linear elastic brittle material. The material was considered isotropic before cracking but after cracking the material becomes anisotropic by the presence of the cracks. The frame-panel modeled by using a bar type element to simulate separation and slip (Liauw and Kwan, 1985).

A continuum approach was proposed by Lotfi and Shing (1991) that participate in the stress locking problem a smeared cracked model cannot capture the sliding failure of a mortar joint. Consequently, a more accurate simulation of the failure behavior needs a precise model of each brick and mortar joints with continuum elements and their interconnection with cohesive interface elements.

After Shing *et al.* (1992) have given special importance to the interaction between infilled panels and bare frames. Several approaches have been proposed to present the infill panels based on the technique modelling proposed for concrete and rock mechanics.

The presence of mortar joints which increase the weakness of infill panels in the unreinforced masonry structures subjected to lateral loads make the comportment of masonry more difficult. The failure of unreinforced masonry influenced by the crack of mortar joints and crushing of masonry units. The finite element approach had been used for modelling the mortar joints and the masonry with the interface elements were modeled with the smeared crack elements. So, a model with dilatant interface has been used to simulate the initiation and propagation of interface fracture under combined normal and shear stresses (Lotfi and Shing, 1994).

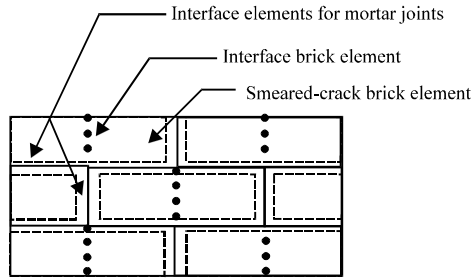

Fig. 22: Finite-element discretization of masonry infill

The analytical modeling of infilled panels can be represented by refined discretization with continuum elements (Mosalam *et al.*, 1997; Mehrabi and Shing, 1994).

For the development and the calibration of nonlinear finite element, the evaluation of the seismic performance of masonry-infilled reinforced concrete frames has been treated. A modelization combines the smeared and discrete crack approaches was considered to capture different failure modes of infilled frames with the mixed mode fracture of mortar joints and the shear failure. A discretization had been proposed Fig. 22 in which the masonry unit is modeled by two rectangular continuum elements that are interconnected with a vertical interface element which permit to the tensile splitting of each brick and the relative sliding motion in a cracked unit (Stavridis and Shing, 2010).

To simulate the fracture of the brick units and mortar joints (Lotfi, 1992; Attard *et al.*, 2007), modeled masonry panels by a series of continuum elements and interface line elements, based on this approach (Al-Chaar and Mehrabi, 2008), the behavior of masonry infilled reinforced concrete frames had been simulated.

**Frame modelling:** Beams elements which have a simple geometry and limited degree of freedom had been used by Mallick and Garg (1971), King and Pandey (1978) and Dawe and Yong (1985) to represent the analytical model of the surrounding frame.

Tie-link elements for connecting boundary nodes of the panel with the surrounding frame had been used by several researchers (Fig. 23), every node of elements characterized by two translational degrees of freedom. The element is capable to transmit the bond and compressive forces and unable of resisting to tensile forces (King and Pandey, 1978; Dawe and Yong, 1985).

**Modeling of interfaces:** The analytical representation of the interaction between the infill panel and the frame has

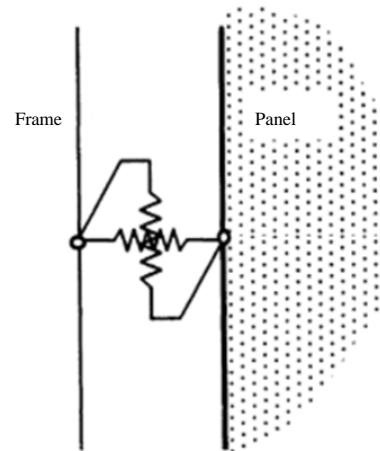

Fig. 23: The behavior of the panel-frame interface using tie-link element

been represented by interface elements or tie-link which gives the effects produced in the interfaces between the surrounding frame and the infill panel.

Mallick and Severn (1967) developed an iterative scheme using a finite element model which have in the interface between frame and panel zone an additional contact force. Researchers, König (1991) and Mosalam *et al.* (1997) give a more precise description of the panel-frame interfaces. A modified interface element had been developed by King and Pandey (1978) in which one of the surfaces presents two perpendicular, rigid links to represent the depth of the frame member, the nodes related to the rigid links have a rotational degree of freedom. Mosalam *et al.* (1997), Liauw and Kwan (1985), developed a similar approach but they remark that the interface elements can be sensitive to the mesh implemented in the analysis.

To model the interface between the frame and the infill and the mortar joints surrounding the blocks of masonry a non-associated interface model is formulated using the test data on masonry joints (Polyakov, 1957).

**The behavior of building:** The presence of infill panels in reinforced concrete frames, modify the lateral-loads transfer mechanism of buildings from one of predominantly frame action (Fig. 24a) to one of predominantly shear action (Fig. 24b), besides, they can transform the lateral seismic force to compression axial loads along their diagonals (Murty *et al.*, 2002).

Two types of testing schemes usually utilized by researchers, the first one was an in plane, diagonal and compressive loading of a single frame unit and the second was in-plane racking test in which the frame had been

subjected to a top lateral load (Hakam, 2000). Holmes (1961), Smith (1962a, b, 1967), Mainstone and Weeks (1970), Dawe and Seah (1989), Flangan *et al.* (1992) and Mander *et al.* (1993) have studied the behavior of masonry infilled steel frames under lateral loads (Mehrabi *et al.*, 1996).

Nine steel frames with different infill properties under reversed cycling loading were investigated experimentally. Different span/height ( $l/h$ ) ratios frames of one storey with various infill panel properties were assembled to simulate the seismic load. After, the displacement occurring at the specimens was measured. Also, the strength envelopes, rigidity decreases and energy dissipation of the infilled frames were determined and the results obtained were compared (Table 1 and Fig. 25). After these experimental investigations, the following results were obtained. The lateral load bearing capacity, lateral rigidity and energy dissipation capacity were depending on the characteristic of the infill wall.

The ratio of the infill walls span/height ( $l/h > 1$ ) increases considerably the lateral load bearing capacity and it decreases when the ratio of wall span/height ( $l/h < 1$ ). As a results of brick walls with plaster, the lateral failure load, lateral rigidity and energy dissipation capacity of the infilled frame system increase. For this reason, special care should be given to using plaster in applications (Kaltakci *et al.*, 2008) (Table 2-7).

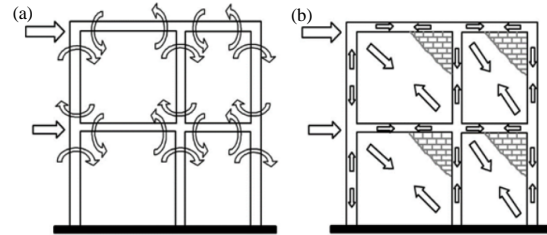

Fig. 24: Change in lateral-load transfer mechanism due to masonry infills

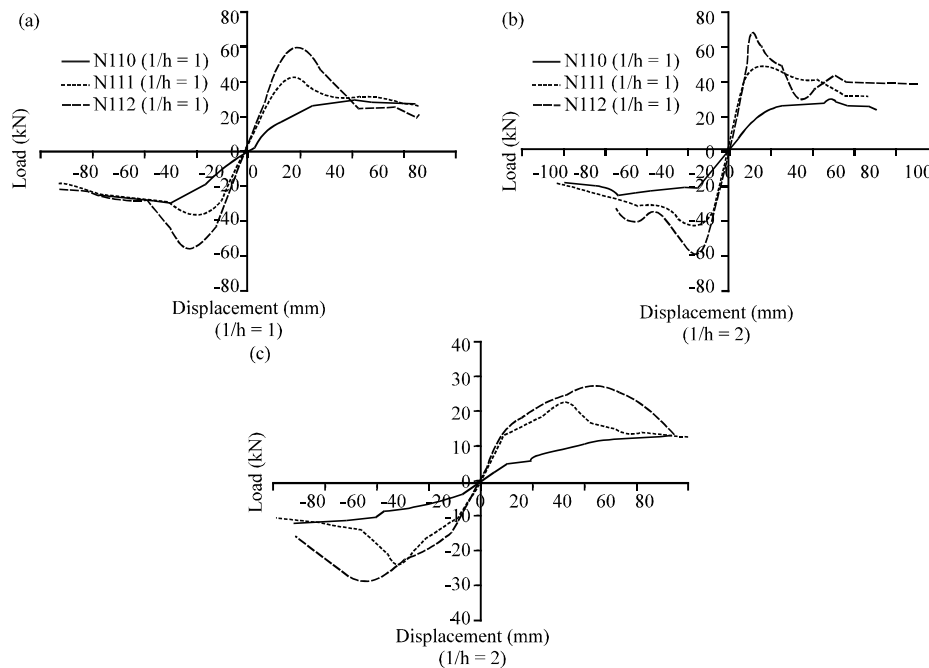

Fig. 25: Strength envelopes of frame systems having different infill wall span/height

Table 2: Physical and geometrical characteristics of test specimens and experimental results

| Specimens                               | Frame span/height ( $l/h$ ) | Experimental maximum lateral load |                | Initial rigidity (kN/mm) |
|-----------------------------------------|-----------------------------|-----------------------------------|----------------|--------------------------|
|                                         |                             | Load (kN)                         | ( $\delta/H$ ) |                          |
| N110 ( $l/h = 1$ ) No infill (empty)    | 843/823                     | 32.37                             | 0.0994         | 1.46                     |
| N111 ( $l/h = 1$ ) Brick-wall infill    | 843/823                     | 41.42                             | 0.0247         | 10.75                    |
| N112 ( $l/h = 1$ ) Brick-wall+plaster   | 843/823                     | 56.92                             | 0.0247         | 19.30                    |
| N110 ( $l/h = 2$ ) No infill (empty)    | 1643/823                    | 27.15                             | 0.0722         | 1.28                     |
| N111 ( $l/h = 2$ ) Brick-wall infill    | 1643/823                    | 45.50                             | 0.0241         | 13.20                    |
| N112 ( $l/h = 2$ ) Brick-wall+plaster   | 1643/823                    | 63.23                             | 0.0243         | 25.80                    |
| N110 ( $l/h = 1/2$ ) No infill (empty)  | 843/1603                    | 12.97                             | 0.0510         | 0.46                     |
| N111 ( $l/h = 1/2$ ) Brick-wall infill  | 843/1603                    | 23.64                             | 0.0244         | 3.72                     |
| N112 ( $l/h = 1/2$ ) Brick-wall+plaster | 843/1603                    | 28.60                             | 0.0322         | 6.10                     |

Table 3: Energy consumed at the end of the test

| Specimens                           | Ultimate rigidity |                | Energy consumed at the end of the test |                           |
|-------------------------------------|-------------------|----------------|----------------------------------------|---------------------------|
|                                     | Rigidity (kN/mm)  | ( $\delta/H$ ) | Cumulative consumed energy (kN/mm)     | Cumul. $\Sigma(\delta/H)$ |
| N110(l/h = 1) No infill (empty)     | 0.40              | 0.0994         | 10878                                  | 0.422                     |
| N111 (l/h = 1) Brick-wall infill    | 0.23              | 0.1108         | 14877                                  | 0.437                     |
| N112 (l/h = 1) Brick-wall+plaster   | 0.15              | 0.0986         | 17978                                  | 0.416                     |
| N110 (l/h = 2) No infill (empty)    | 0.23              | 0.1115         | 13237                                  | 0.435                     |
| N111 (l/h = 2) Brick-wall infill    | 0.33              | 0.1019         | 17406                                  | 0.437                     |
| N112 (l/h = 2) Brick-wall+plaster   | 0.33              | 0.1323         | 17886                                  | 0.439                     |
| N110 (l/h = 1/2) No infill (empty)  | 0.14              | 0.0538         | 2991                                   | 0.285                     |
| N111 (l/h = 1/2) Brick-wall infill  | 0.13              | 0.0560         | 5871                                   | 0.275                     |
| N112 (l/h = 1/2) Brick-wall+plaster | 0.17              | 0.0552         | 7429                                   | 0.281                     |

Table 4: Experimental works (bibliography)

| Researchers                                               | Frame type                                                          | Characteristic of infill                                                                                                          |
|-----------------------------------------------------------|---------------------------------------------------------------------|-----------------------------------------------------------------------------------------------------------------------------------|
| Holmes (1961)                                             | Steel frame                                                         | Concrete brick                                                                                                                    |
| Smith (1962a, b, 1967)                                    | Steel frame                                                         | Mortar brick                                                                                                                      |
| Nagar                                                     |                                                                     | Masonry, mortar (presence of openings) and unreinforced masonry                                                                   |
| Murty and Nagar (1996)                                    |                                                                     | Masonry infills                                                                                                                   |
| Elouali                                                   | Steel frame                                                         | Masonry, hollow concrete blocks and hollow clay tile blocks                                                                       |
| Hossein and Toshimi (2004)                                | Reinforced concrete building                                        | Masonry panels                                                                                                                    |
| Shedid (2006)                                             |                                                                     | Reinforced concrete masonry walls                                                                                                 |
| Shedid <i>et al.</i> (2008)                               |                                                                     | Reinforced concrete walls                                                                                                         |
| Fiorato <i>et al.</i> (1970)                              | Reinforced concrete frames                                          | Masonry infilled                                                                                                                  |
| Zarnic and Tomazevic (1985)                               | Reinforced concrete frames                                          | Masonry infilled                                                                                                                  |
| Mehrabi <i>et al.</i> (1994)                              | Reinforced concrete frames                                          | Masonry infilled                                                                                                                  |
| Angel <i>et al.</i> (1994)                                | Reinforced concrete frames                                          | Masonry infilled                                                                                                                  |
| Mosalam <i>et al.</i> (1997), Flanagan and Bennett (1999) | Reinforced concrete frames                                          | Masonry infilled                                                                                                                  |
| Buonopane and White (1999)                                | Reinforced concrete frames                                          | Masonry infilled                                                                                                                  |
| Fiorato <i>et al.</i> (1970) and Liauw and Kwan (1985)    | Reinforced concrete frames                                          | Masonry infilled                                                                                                                  |
| Mehrabi and Shing (2002)                                  | Reinforced concrete frames                                          | Masonry infilled                                                                                                                  |
| Kasym <i>et al.</i>                                       | 3 storey reinforced frame                                           | Different patterns of masonry infill walls                                                                                        |
| Murty and Jain (2000)                                     | Unreinforced masonry and unanchored and anchored reinforced masonry | Clay brick masonry in cement mortar                                                                                               |
| Kaltakci <i>et al.</i> (2008)                             | Steel frames                                                        | No infill/Brick-wall infill/brick wall+plaster                                                                                    |
| Alberto <i>et al.</i>                                     | Steel bar                                                           | Non-injected masonry and injected masonry with specific mortar product                                                            |
| Andre <i>et al.</i>                                       | Reinforced concrete frames                                          | Masonry infill walls                                                                                                              |
| Marco <i>et al.</i>                                       |                                                                     | Panels were reinforced with a GFRP grid and non-reinforced panels underwent shear failure involving only lime-based mortar joints |

Table 5: Type of load

| Researchers                                                    | Type of load                                    | Remarks                                                                                                                                                                                                                                                                                        |
|----------------------------------------------------------------|-------------------------------------------------|------------------------------------------------------------------------------------------------------------------------------------------------------------------------------------------------------------------------------------------------------------------------------------------------|
| Holmes (1961)                                                  | Cyclic loads                                    | 19 essay                                                                                                                                                                                                                                                                                       |
| Smith (1962a, b, 1967)                                         | Cyclic loads                                    | 33 essay                                                                                                                                                                                                                                                                                       |
| Nagar                                                          | Cyclic loads                                    | 5 essay                                                                                                                                                                                                                                                                                        |
| Murty and Nagar (1996)                                         | Cyclic loads                                    |                                                                                                                                                                                                                                                                                                |
| Elouali                                                        | Cyclic loads                                    |                                                                                                                                                                                                                                                                                                |
| Hossein and Toshimi (2003)                                     |                                                 |                                                                                                                                                                                                                                                                                                |
| Kabeyasawa                                                     | Cyclic loads                                    | 3 dimension nonlinear analysis of concrete building                                                                                                                                                                                                                                            |
| Shedid (2006)                                                  | Cyclic loads                                    |                                                                                                                                                                                                                                                                                                |
| Shedid <i>et al.</i> (2008)                                    | Cyclic loads                                    |                                                                                                                                                                                                                                                                                                |
| Fiorato <i>et al.</i> (1970)                                   | Cyclic loads                                    | Eight-scale models; Mode A (flexural mode) and mode B (Midheight crack)                                                                                                                                                                                                                        |
| Zarnic and Tomazevic (1985)                                    | Cyclic loads                                    | Mode B (Midheight crack)                                                                                                                                                                                                                                                                       |
| Mehrabi <i>et al.</i> (1994)                                   | Cyclic loads                                    | Mode C (Diagonal crack) and Mode D (Horizontal slip) and the mode E (Corner crushing)                                                                                                                                                                                                          |
| Angel <i>et al.</i> (1994)                                     | Cyclic loads                                    | Mode C (Diagonal crack)                                                                                                                                                                                                                                                                        |
| Mosalam <i>et al.</i> (1997), Flanagan and Bennett (1999)      | Cyclic loads                                    | Mode C (Diagonal crack)                                                                                                                                                                                                                                                                        |
| Buonopane and White (1999)                                     | Cyclic loads                                    | Mode D (Horizontal slip)                                                                                                                                                                                                                                                                       |
| Fiorato <i>et al.</i> (1970) and Te-Chang and Kwok-Hung (1984) | Cyclic loads                                    | Probable failure modes                                                                                                                                                                                                                                                                         |
| Mehrabi and Shing (2002)                                       | Cyclic loads                                    | Equation to calculate the five probable failure modes                                                                                                                                                                                                                                          |
| Kasym <i>et al.</i>                                            | Cyclic loads                                    | Pushover curves; base shear, storey drifts, relative storey displacement; the presence of infill masonry walls significantly and positively alters the seismic performance of the structure, its irregular vertical distribution causes some negative effects including soft storey phenomenon |
| Murty and Jain (2000)                                          | Reverse cyclic displacement -controlled loading | Infill masonry is made with full-scale (223×112×68 mm) and 1:2 reduced-scales (116×54×36 mm) burnt-clay bricks                                                                                                                                                                                 |
| Kaltakci <i>et al.</i> (2008)                                  | Reversed -cycling loading                       | Nine steel frames with different infill properties                                                                                                                                                                                                                                             |

Table 5: Continue

| Researchers           | Type of load                            | Remarks                                                                                             |
|-----------------------|-----------------------------------------|-----------------------------------------------------------------------------------------------------|
| Alberto <i>et al.</i> | Series a load cell                      | Two external layers (approximately 15 cm of thickness)                                              |
| Andre <i>et al.</i>   | Nonlinear dynamic time-history analysis | 8 Storey building considering the effect of the IM out-of-plane behavior in the structural response |
| Marco <i>et al.</i>   | Lateral loads                           | Shear tests on 17 wall panels before and after reinforcement (1200*1200 mm panels)                  |

Table 6: Parameters studied according to dissipated energy

| Researchres                                               | Stiffness | Strength | Ductility | Dissipated energy |
|-----------------------------------------------------------|-----------|----------|-----------|-------------------|
| Holmes (1961)                                             | X         | X        |           |                   |
| Smith (1962a, b, 1967)                                    | X         | X        |           |                   |
| Nagar                                                     | X         | X        |           |                   |
| Murty and Nagar (1996)                                    | X         | X        | X         | X                 |
| Elouali                                                   | X         | X        |           | X                 |
| Hossein and Toshimi (2004)                                | X         |          |           |                   |
| Shedid (2006)                                             |           | X        | X         | X                 |
| Shedid <i>et al.</i> (2008)                               | X         | X        | X         | X                 |
| Fiorato <i>et al.</i> (1970)                              |           | X        |           |                   |
| Zarnic and Tomazevic (1985)                               |           | X        |           |                   |
| Mehrabi <i>et al.</i> (1994)                              |           | X        |           |                   |
| Angel <i>et al.</i> (1994)                                |           | X        |           |                   |
| Mosalam <i>et al.</i> (1997), Flanagan and Bennett (1999) |           | X        |           |                   |
| Buonopane and White (1999)                                |           | X        |           |                   |
| Fiorato <i>et al.</i> (1970) and Liauw and Kwan (1985)    | X         | X        |           |                   |
| Mehrabi and Shing (2002)                                  |           | X        |           |                   |
| Kasym <i>et al.</i>                                       | X         | X        |           |                   |
| Murty and Jain (2000)                                     | X         | X        | X         | X                 |
| Kaltakci <i>et al.</i> (2008)                             | X         | X        |           | X                 |
| Alberto <i>et al.</i>                                     |           | X        | X         |                   |
| Andre <i>et al.</i>                                       | X         | X        |           | X                 |
| Marco <i>et al.</i>                                       | X         | X        |           |                   |

Table 7: Parameters studied according to displacement

| Researchers                                               | Period | seismic response | Damping | Failure mode | Displacement |
|-----------------------------------------------------------|--------|------------------|---------|--------------|--------------|
| Holmes (1961)                                             |        |                  |         | X            |              |
| Smith (1962a, b, 1967)                                    |        |                  |         | X            |              |
| Nagar                                                     |        | X                |         |              |              |
| Murty and Nagar (1996)                                    | X      |                  | X       |              | X            |
| Elouali                                                   | X      | X                |         |              | X            |
| Hossein and Toshimi (2004)                                |        | X                | X       |              | X            |
| Shedid (2006)                                             |        | X                | X       | X            | X            |
| Shedid <i>et al.</i> (2008)                               |        | X                |         |              | X            |
| Fiorato <i>et al.</i> (1970)                              |        |                  |         | X            |              |
| Zarnic and Tomazevic (1985)                               |        |                  |         | X            |              |
| Mehrabi <i>et al.</i> (1994)                              |        |                  |         | X            |              |
| Angel <i>et al.</i> (1994)                                |        |                  |         | X            |              |
| Mosalam <i>et al.</i> (1997), Flanagan and Bennett (1999) |        |                  |         | X            |              |
| Buonopane and White (1999)                                |        |                  |         | X            |              |
| Fiorato <i>et al.</i> (1970), Liauw and Kwan (1985)       |        |                  |         | X            |              |
| Mehrabi and Shing (2002)                                  |        |                  |         | X            |              |
| Kasym <i>et al.</i>                                       |        | X                |         |              | X            |
| Murty and Jain (2000)                                     |        | X                |         |              | X            |
| Kaltakci <i>et al.</i> (2008)                             |        |                  |         |              | X            |
| Alberto <i>et al.</i>                                     |        |                  |         |              | X            |
| Andre <i>et al.</i>                                       | X      | X                |         |              |              |
| Marco <i>et al.</i>                                       | X      |                  |         |              |              |

### CONCLUSION

The following table gives a summary of some experiences with different parameters and geometric characteristic taking into consideration during the experiences.

Masonry infill walls are widely used in structures. However, they are considered as non-structural elements, even if, they have an important contribution in enhancing

the structural strength, stiffness and energy dissipation. The lessons learned from the past earthquakes, the presence of much damage in several constructions proves that there is a big interaction between bare frames and infill panels which usually modify the behavior of structural elements, furthermore, it can lead to undesirable consequences. So, the actual analysis methods and designs still don't reflect more approximately the real behavior of infilled frames. In order to propose a more

realistic model than the reviewed ones in this study, our research and experiments will focus on reducing the seismic vulnerability of the infill walls which could lead to the reduction of the influence of earthquake on structures.

The results obtained by the majority of researchers show that the infill walls with their different mechanical and geometrical characteristics influence in a direct way on the stiffness, strength and energy dissipation of the bare frame, thus the presence of these infill walls changes remarkably the dynamic behavior of the structure. From the results of reviewed literature which is based on various researches we concluded that.

More investigation must be done on the analytical modeling of hysteretic response of infilled panels. Not much precise studies on the inelastic response spectrum of infilled frames.

Generally infilled panels are replaced by equivalent strut model, more equivalent models must be studied. The proposed materials of infilled panels must be enriched by other type that could modify in a positive manner the effect of the infill panels on the stiffness, strength and energy dissipation of the surrounding frame.

## RECOMMENDATIONS

There is a clear need for further research on the failure regime taking into account the possible variation of uniaxial panel strength, angle of inclination of the bed joints, taking account several parameters of infill panel.

Most of the research had been done in the linear domain. Not enough information on the degradation of stiffness, strength and nonlinear comportment. Infill properties still not adequately defined. Tests under alternating quasi-static loading are needed to define the behavior of different element of structure.

## REFERENCES

- Al-Chaar, G.L. and A. Mehrabi, 2008. Constitutive models for nonlinear finite element analysis of masonry prisms and infill walls. Ph.D Thesis, Engineer Research and Development Center (ERDC), United States Army Corps of Engineers, Washington, D.C., USA.
- Andreaus, U., M. Cerone, P. D'Asdia and F. Iannozzi, 1985. A finite element model for the analysis of masonry structures under cyclic actions. Proceedings of the 7th International Conference on Brick Masonry Vol. 1, February 17-20, 1985, Brick Development Research Institute, Melbourne, Australia, pp: 479-488.
- Angel, R., D.P. Abrams, D. Shapiro, J. Uzarski and M. Webster, 1994. Behavior of reinforced concrete frames with masonry infills. Master Thesis, University of Illinois at Urbana-Champaign, Champaign County, Illinois.
- Attard, M.M., A. Nappi and F. Tin-Loi, 2007. Modeling fracture in masonry. *J. Struct. Eng.*, 133: 1385-1392.
- Buonopane, S.G. and R.N. White, 1999. Pseudo dynamic testing of masonry infilled reinforced concrete frame. *J. Struct. Eng.*, 125: 578-589.
- Chrysostomou, C.Z., 1991. Effects of degrading infill walls on the nonlinear seismic response of two-dimensional steel frames. Ph.D Thesis, Cornell University, Ithaca, New York, USA.
- Crisafulli, F.J., 1997. Seismic behaviour of reinforced concrete structures with masonry infills. Ph.D Thesis, University of Canterbury, Christchurch, New Zealand.
- Dawe, J.L. and C.K. Seah, 1989. Behaviour of masonry infilled steel frames. *Can. J. Civ. Eng.*, 16: 865-876.
- Dawe, J.L. and T.C. Yong, 1985. An investigation of factors influencing the behaviour of masonry infill in steel frames subjected to in-plane shear. Proceedings of the 7th International Conference on Brick Masonry Vol. 2, February 17-20, 1985, Brick development Research Institute, Melbourne, Australia, pp: 803.
- Doudoumis, I.N. and E.N. Mitsopoulou, 1986. Non-linear analysis of multi-storey infilled frames for unilateral contact condition. Proceedings of the 8th European Conference on Earthquake Engineering Vol. 3, September 7-12, 1986, European Association for Earthquake Engineering (EAEE), Istanbul, Turkey, pp: 63-70.
- Durrani, A.J. and Y.H. Luo, 1994. Seismic retrofit of flat-slab buildings with masonry infills. Master Thesis, National Center for Research on Earthquake Engineering, Taipei, Taiwan.
- Fiorato, A.E., M.A. Sozen and W.L. Gamble, 1970. An investigation of the interaction of reinforced concrete frames with masonry filler walls. MSc Thesis, University of Illinois at Urbana-Champaign, Champaign County, Illinois.
- Flanagan, R.D. and R.M. Bennett, 1999. In-plane behavior of structural clay tile infilled frames. *J. Struct. Eng.*, 125: 590-599.
- Flanagan, R.D., R.M. Bennett and G.A. Barclay, 1992. Experimental testing of hollow clay tile infilled frames. Proceedings of the 6th Conference on Canadian Masonry Symposium, Saskatoon (Canada), June 15-18, 1992, University of Saskatchewan, Saskatoon, Saskatchewan, pp: 789-799.

- Franchi, A., P. Crespi, P. Ronca and F. Pizzamiglio, 2014. An in situ diagonal compression test for brick walls with displacement control on the two external layers. *Intl. J. Hous. Sci.*, 38: 37-42.
- Ghosh, A.K. and A.M. Amde, 2002. Finite element analysis of infilled frames. *J. Struct. Eng.*, 128: 881-889.
- Hakam, Z.H.R., 2000. Retrofit of hollow concrete masonry infilled steel frames using glass fiber reinforced plastic laminates. Ph.D Thesis, Drexel University, Philadelphia, Pennsylvania.
- Hilsdorf, H.K., 1969. An Investigation into the Failure Mechanism of Brick Masonry Loaded in Axial Compression. In: *Designing Engineering and Constructing with Masonry Products*, Johnson, F.B. (Ed.). Gulf Publishing, Houston, Texas, pp: 34-41.
- Holmes, M., 1961. Steel frames with brickwork and concrete infilling. *Proc. Inst. Civ. Eng.*, 19: 473-478.
- Hosseini, M. and K. Toshimi, 2004. Effect of infill masonry walls on the seismic response of reinforced concrete buildings subjected to the 2003 Bam earthquake strong motion: A case study of Bam telephone center. *Bull. Earthquake Res. Inst.*, 79: 133-156.
- Jain, S.K., C.V.R. Murty, J.N. Arlekar, R. Sinha and A. Goyal *et al.*, 1997. Some observations on engineering aspects of the Jabalpur earthquake of 22 May 1997. *EERI. Spec. Earthquake Rep. Newsl.*, 32: 1-17.
- Kaltakci, M.Y., A. Koken and H.H. Korkmaz, 2008. An experimental study on the behavior of infilled steel frames under reversed-cycling loading. *Iran. J. Sci. Technol.*, 32: 157-160.
- Kawa, M., S. Pietruszczak and B. Shieh-Beygi, 2008. Limit states for brick masonry based on homogenization approach. *Intl. J. Solids Struct.*, 45: 998-1016.
- King, G.J.W. and P.C. Pandey, 1978. The analysis of infilled frames using finite elements. *Proc. Inst. Civ. Eng.*, 65: 749-760.
- Klingner, R.E. and V.V. Bertero, 1976. *Infilled Frames in Earthquake-Resistant Construction*. University of California, Berkeley, Berkeley, USA., Pages: 548.
- Klingner, R.E. and V.V. Bertero, 1978. Earthquake resistance of infilled frames. *J. Struct. Div.*, 104: 973-989.
- Konig, G., 1991. The State of the Art in Earthquake Engineering Research. In: *Experimental and Numerical Methods in Earthquake Engineering*, Donea, J. and P.M. Jones (Eds.). Kluwer Academic Publisher, Dordrecht, Netherlands, USA., pp: 21-22.
- Korkmaz, K.A., F. Demir and M. Sivri, 2007. Earthquake assessment of R/C structures with masonry infill walls. *Intl. J. Sci. Technol.*, 2: 155-164.
- Liaum, T. and K. Kwan, 1982. Non-linear analysis of multistorey infilled frames. *Proc. Inst. Civ. Eng.*, 73: 441-454.
- Liau, T.C. and K.H. Kwan, 1985. Unified plastic analysis for infilled frames. *J. Struct. Eng.*, 111: 1427-1448.
- Lotfi, H.R. and P.B. Shing, 1991. An appraisal of smeared crack models for masonry shear wall analysis. *Comput. Struct.*, 41: 413-425.
- Lotfi, H.R. and P.B. Shing, 1994. Interface model applied to fracture of masonry structures. *J. Struct. Eng.*, 120: 63-80.
- Lotfi, H.R., 1992. Finite element analysis of fracture of concrete and masonry structures. Ph.D Thesis, University of Colorado Boulder, Boulder, Colorado.
- Mainstone, R.J. and G.A. Weeks, 1970. The influence of bounding frame on the racking stiffness and strength of brickwalls. *Proceedings of the 2nd International Conference on Brick Masonry*, April 12-15, 1970, British Ceramic Research Association, Stoke on Trent, England, UK., pp: 165-171.
- Mainstone, R.J., 1971. On stiffness and strength of infilled frames. *Proc. Inst. Civ. Eng.*, 7360: 57-90.
- Mallick, D.V. and R.P. Garg, 1971. Effect of openings on the lateral stiffness of infilled frames. *Proc. Inst. Civ. Eng.*, 49: 193-209.
- Mallick, D.V. and R.T. Severn, 1967. The behaviour of infilled frames under static loading. *Proc. Inst. Civ. Eng.*, 38: 639-656.
- Mander, J.B., B. Nair, K. Wojtkowski and J. Ma, 1993. An experimental study on the seismic performance of brick-infilled steel frames with and without retrofit. Master Thesis, National Center for Research on Earthquake Engineering, University at Buffalo, Buffalo, New York, USA.
- Mehrabi, A.B. and P.B. Shing, 1994. Performance of masonry-infilled R/C frames under in-plane lateral loads: Analytical modeling. *Proceedings of the NCEER Workshop on Seismic Response of Masonry*, February 4-5, 1994, NCEER, San Francisco, California, pp: 1-45-1-50.
- Mehrabi, A.B., B.P. Shing, M.P. Schuller and J.L. Noland, 1996. Experimental evaluation of masonry-infilled RC frames. *J. Struct. Eng.*, 122: 228-237.
- Mehrabi, A.B., P.B. Shing, M.P. Schuller and J.L. Noland, 1994. Performance of masonry-infilled R/C frames under in-plane lateral loads. National Science Foundation, Alexandria, Virginia. <https://nehresearch.nist.gov/article/PB95-174025/XAB>.
- Mosalam, K.M., R.N. White and P. Gergely, 1997. Static response of infilled frames using quasi-static experimentation. *J. Struct. Eng.*, 123: 1462-1469.



- Murty, C.V.R. and A. Nagar, 1996. Effect of brittle masonry infills on displacement and ductility demand of moment resisting frames. Proceedings of 11th World Conference on Earthquake Engineering, June 23-28, 1996, Mexican Society of Earthquake Engineering, Acapulco, Mexico, pp: 1-6.
- Murty, C.V.R. and S.K. Jain, 2000. Beneficial influence of masonry infill walls on seismic performance of RC frame buildings. Proceedings of the 12th World Conference on Earthquake Engineering, January 30-February 4, 2000, New Zealand Society for Earthquake Engineering Inc., Auckland, New Zealand, pp: 1-6.
- Murty, C.V.R., R.K. Goel, A. Goyal, S.K. Jain and R. Sinha *et al.*, 2002. Reinforced concrete structures. *Earthquake Spectra*, 18: 149-185.
- Polyakov, S.V., 1957. *Masonry in Framed Buildings: An Investigations into the Strength and Stiffness of Masonry Infilling*. Moscow Publisher, Moscow, Russia.
- Shedid, M., 2006. Ductility of reinforced concrete masonry shear walls. MSc Thesis, McMaster University, Hamilton, Ontario.
- Shedid, M.T., R.G. Drysdale and W.W. El-Dakhkhni, 2008. Behavior of fully grouted reinforced concrete masonry shear walls failing in flexure: Experimental results. *J. Struct. Eng.*, 134: 1754-1767.
- Shing, P.B., H.R. Lofti, A. Barzegarmehrabi and J. Burner, 1992. Finite Element Analysis of Shear Resistance of Masonry Wall Panels with and Without Confining Frames. In: Proceedings of the 10th World Conference on Earthquake Engineering, Bernal, A. (Ed.). A.A. Balkema, Rotterdam, Netherlands, ISBN:9054100699, pp: 2581-2586.
- Smith, B.S. and C. Carter, 1969. A method of analysis for infilled frames. *Proc. Inst. Civ. Eng.*, 44: 31-48.
- Smith, B.S., 1962b. Lateral stiffness of infilled frames. *J. Struct. Div.*, 88: 183-226.
- Smith, B.S., 1962a. Lateral stiffness of infilled frames. *J. Struct. Eng. Div. Am. Soc. Civil Eng.*, 88: 183-190.
- Smith, B.S., 1967. Methods for predicting the lateral stiffness and strength of multi-storey infilled frames. *Build. Sci.*, 2: 247-257.
- Smith, B.S., 1996. Behavior of square infilled frames. *J. Struct. Div.*, 92: 381-404.
- Stavridis, A. and P.B. Shing, 2010. Finite-element modeling of nonlinear behavior of masonry-infilled RC frames. *J. Struct. Eng.*, 136: 285-296.
- Syrmakezis, C.A. and P.G. Asteris, 2001. Masonry failure criterion under biaxial stress state. *J. Mater. Civ. Eng.*, 13: 58-64.
- Te-Chang, L. and K. Kwok-Hung, 1984. Nonlinear behaviour of non-integral infilled frames. *Comput. Struct.*, 18: 551-560.
- Zarnic, R. and M. Tomazevic, 1985. Study of the behaviour of masonry infilled reinforced concrete frames subjected to seismic loading. Proceedings of the 7th International Conference on Brick Masonry, February 17-20, 1985, Brick Development Research Institute, Melbourne, Australia, pp: 1315-1325.
- Zarnic, R. and M. Tomazevic, 1988. An experimentally obtained method for evaluation of the behavior of masonry infilled RC frames. Proceedings of the 9th World Conference on Earthquake Engineering Vol. 6, August 2-9, 1998, Japan Association for Earthquake Engineering, Tokyo, Japan, pp: VI-163-VI-168.