

Determination of the Output Impedance of the Injecting Current Source for Electrical Impedance Tomography

G.K. Aleksanyan, I.D. Shcherbakov, A.I. Kucher and N.I. Gorbatenko
Department of Information and Measurement Systems and Technologies,
Platov South Russia State Polytechnic University (NPI), Novocherkassk, Russia

Abstract: The output impedance is one of the most important parameters of the current source in the composition of the information-measuring system of electrical impedance tomography on which the metrological characteristics of the entire system depend. In this study, a setup was developed for conducting studies of the output impedance of the current source in a given amplitude range and frequency of the output current. Studies of the output impedance of the current source were carried out as a result, a characteristic was obtained, the use of which will further help to improve the design of the device for electrical impedance tomography.

Key words: Electrical impedance tomography, current source, impedance, characteristic, tomography, electrical

INTRODUCTION

The study describes the studies output parameters of the current source Electrical Impedance Tomography (EIT) device component (Aleksanyan *et al.*, 2016). The current source is the most important component of the equipment for EIT which determines the metrological characteristics of the entire measuring path (Aleksanyan *et al.*, 2017a, b; Bertemes-Filho *et al.*, 2000).

MATERIALS AND METHODS

The current source being developed should meet the following requirements:

- Voltage management
- Current amplitude through the load: 5 mA (Kulikov, 2010)
- Current amplitude error-no more than 1.5%
- Maximum current frequency -100 kHz
- Grounded load resistance R_H -50 Ω -2 k Ω (Aleksanyan *et al.*, 2017a, b)

The use of an inverting or electromechanical amplifiers with a load in the feedback circuit is impossible due to the fact that a constant potential cannot be applied to either end of the load, since in this case, one output or the inverting input of the op-amp will be shorted (Titze and Schenk, 1982). These requirements are satisfied by the CS scheme with automatic measurement and

regulation of the current in the load (Brazovskiy, 2015). The functional diagram of the developed CS as part of a data collection and transmission device for EIT is presented in Fig. 1.

The output current is measured by the voltage drop U_w on the resistor R_w . For this, a differential amplifier at the op-amp 2 is used. If the gain factor is $K_U = R_d/R_b$ ($R_a = R_1 = R_3$; $R_b = R_2 = R_4$) differential amplifier (Chizhma, 2012) on OP2 is equal to 1, then, the output voltage of the operational amplifier OP1 is set such that the voltage drop U_w on the resistor R_w is equal to the input voltage U_{out} . Increasing the gain K_U allows proportionately reduce the nominal resistance of the resistor R_w . Voltage repeaters at OP3 and OP4 increase the input impedance of the differential amplifier at OP2. The circuit diagram of the developed injecting current source CS is presented in Fig. 2.

Form and frequency f_1 current I at the OUT pin of the current source correspond to the shape and frequency f_m of the control signal U_m at the IN terminal of the current source. Amplitude I_m of at the CS output is proportional to the amplitude U_m control voltage at terminal IN and CS is set Resistor R_2 . The current source starts operation immediately after the appearance of power on the connector 3. Pin CS IN is connected to the common point via a Resistor R_1 to prevent the appearance of I on pin OUT CS due to the impact of the induced voltage on the output IN CS. Used instrumental amplifier AD 8429 ARZ produced by analog devices with a disconnected resistor that sets the gain which allows for the gain of the instrumentation amplifier equal to 1.

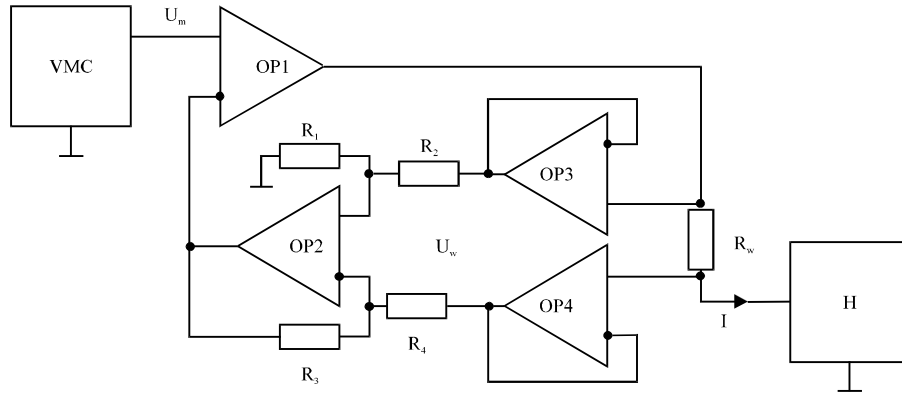

Fig. 1: Functional block diagram of current source of data acquisition and transmission EIT device

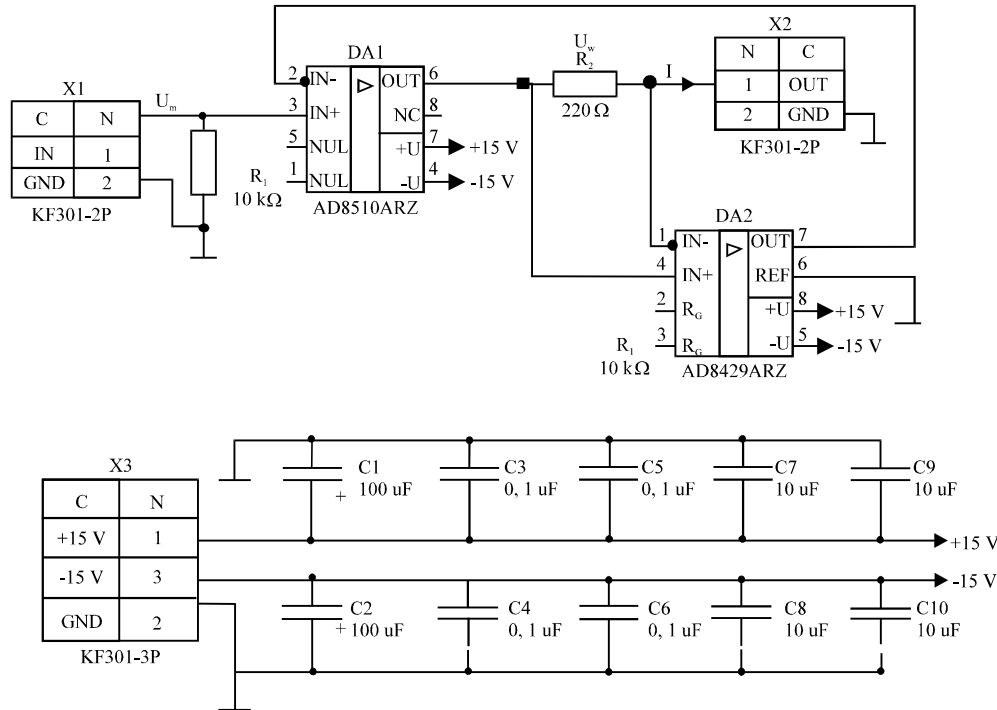

Fig. 2: Circuit diagram of current source of data acquisition and transmission EIT device

The CS PCB was developed in CAD system. The size of the board is 33.3×23.3 mm. The printed circuit board, assembly drawing and the appearance of the assembled source of the injecting current CS are shown in Fig. 3.

One of the most important parameters of the current source which determines its main characteristics is its output impedance R_{out} (Chizhma, 2012). As you know, the ideal current source has an infinitely large output impedance R_{out} . The real current source has a finite resistance R_{out} , connected in parallel to the load resistance R_n (Fig. 4). Due to the fact that R_{out} is finite, current I_{int} will flow through it. Thus, the total current I_n through

the load R_n will be less than output current I of current source on the amount of current I_{int} . It's obvious that:

$$\frac{I_{in}}{I_H} = \frac{R_H}{R_{out}}$$

Thus, in order to influence the output impedance R_o on the current I_n through the load R_n did not exceed 1%, the value of R_{out} must satisfy the condition $R_{out} \geq 100 R_{nmax}$. The value of R_{nmax} for the developed circuit is determined by the value of the current-setting resistance R_w and the maximum resistance which output OP1 can be

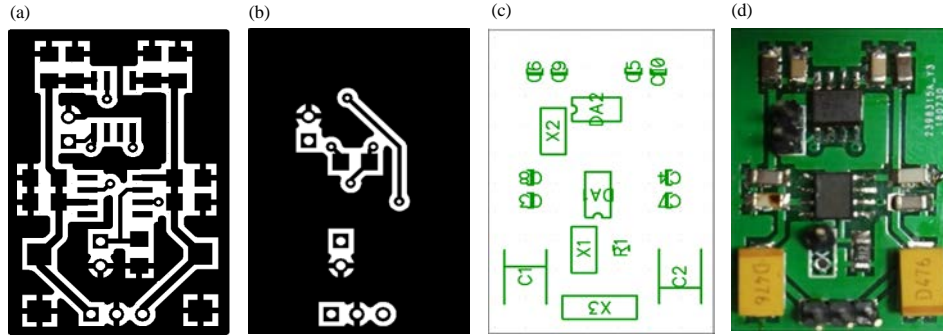

Fig. 3: a) Upper; b) Lower; c) Layers of a printed circuit board, assembly drawing and d) Appearance of current source for a data acquisition and transmission device for EIT

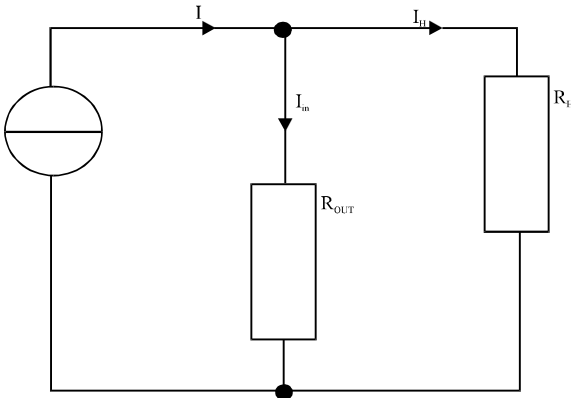

Fig. 4: The equivalent current source circuit with the output resistance

loaded by. For op amp AD 8510ARZ with supply voltage $U = \pm 15 \text{ V}$ maximum output voltage is not $\leq \pm 14 \text{ V}$ (Brazovsky *et al.*, 2015). In order to provide the output current of op-amp at least $I_{DU} = \pm 5 \text{ mA}$ when the output voltage of $\pm 14 \text{ V}$ resistance value R_{VMA} applied to the op-amp output should not exceed $2,600 \Omega$. Since, $R_{VMA} = R_w + R_n + R_k$ (where, R_k is the resistance of the current injection channel which is determined by the resistance of the multiplexers). For the DG 406 multiplexers used, the open channel impedance does not exceed 100Ω and the typical value is 50Ω . Thus, $R_{nmax} = 2180 \Omega$ which satisfies the requirements.

It is impossible to measure the output Resistance R_{out} in a straightforward way. But there are indirect ways to measure R_{out} . Knowing the specified level of current I as well as the value of current I_n through the load resistance R_n for the maximum and minimum value of the load resistance R_n , you can calculate the value of the output resistance CS R_{out} using the equation:

$$R_{out} = \frac{I_{H2} \cdot R_{H2} - I_{H1} \cdot R_{H1}}{I_{H2} - I_{H1}} \quad (1)$$

Table 1: Main alternating current measurement characteristics of the AKIP-2101 voltmeter

Parameters	Values
AC current limits	20 mA/200 mA/2 A/10 A
Resolution	100 nA/1 μ A/10 μ A/100 μ A
Frequent range	20 Hz, ..., 100 kHz
Measurement error	$\pm (0.5, \dots, 2.5\%)$

where, I_{H1} the amplitude of the current through R_n when $R_n = R_{n1}$, I_{H2} the amplitude of the current through R_n when $R_n = R_{n2}$.

For the experimental evaluation of the output resistance R_{out} of CS, we measure the amplitude of the current I_n through a load resistance R_n at maximum and minimum value of load resistance R_n . As the load R_n resistance is used with a nominal value of $R_{n1} = 52 \Omega$ and $R_{n2} = 2155 \Omega$. The experiment is performed for control voltage frequencies f_{cont} (10-100 kHz) and amplitude $I_m = 5 \text{ mA}$. The number of repeated experiments 11. To measure the amplitude of current I_n , a universal AKIP-2101 voltmeter is used (Anonymous, 2014). The main characteristics of AC voltage measurement by the AKIP-2101 voltmeter are summarized in Table 1.

The AKIP-2101 voltmeter allows you to measure the current I_{RMS} value (Anonymous, 2014) of the current, taking into account the waveform and distortion (True RMS). The calculation of the amplitude I_m value is made according to the equation:

$$I_m = I_{RMS} \cdot \sqrt{2}$$

where, I_m the amplitude of the alternating current I_{RMS} is the effective value of alternating current. To generate the control signal U_{cont} a special form generator AKIP-3409/5 is used (Anonymous, 2014). The main characteristics of the generator are summarized in Table 2. The scheme of the experimental stand is shown in Fig. 5 and 6.

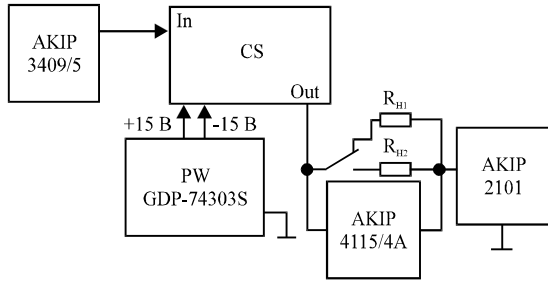

Fig. 5: The block diagram of the experimental stand for the study of current source

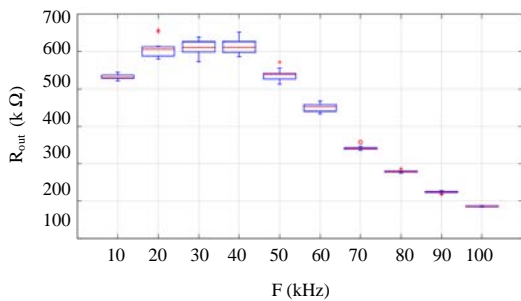

Fig. 6: Output resistance evaluation results

Table 2: The main characteristics of the generator AKIP-3409/5

Parameters	Values
Frequency range (sine)	1 μHz-50 MHz
Frequency resolution	1 μHz
Bit depth of DAC	14 bits
DAC sampling rate	125 MHz
Level setting error at 1 kHz	±(0.01×A+2 mV) with A<1 V ±(0.01×A+10 mV) with A = 1 V
Output level	2 mV _{p-p} -10 V _{p-p}

RESULTS AND DISCUSSION

The results of experimental studies of the current source are shown in Fig. 6. As can be seen from Fig. 6 in the frequency range $f_i = 10, \dots, 100$ kHz with current amplitude $I_m = 5$ mA, the output impedance R_{out} of CS is in the range from 615-186 kΩ. The maximum error for determining the output resistance R_{out} CS is 8% at a frequency of 20 kHz the minimum -1% at a frequency of 100 kHz. Thus, the developed CS allows to provide a current I with amplitude $I_m = 5$ mA and frequency $f_i = 10, \dots, 100$ kHz through the load R_n in the range from 50 Ω-2 kΩ with an error of not more than 1.5%.

CONCLUSION

The output impedance is one of the most important parameters of the current source used in the

information-measuring system of electrical impedance tomography on which the metrological characteristics of the entire system depend. In this study, a setup was developed for conducting studies of the output impedance of the current source in a given amplitude range and frequency of the output current. Studies of the output impedance of the current source were carried out as a result, a characteristic was obtained, the use of which will further help to improve the design of the device for electrical impedance tomography.

ACKNOWLEDGEMENTS

The research is performed within the grant of President of Russian Federation for state support of young Russian scientists MK-196.2017.8 “Development of theoretical foundations and algorithms for multi-view systems are three-dimensional electrical impedance tomography for non-invasive medical imaging”.

REFERENCES

Aleksanyan, G.K., I.D. Shcherbakov and A.I. Kucher, 2017a. Feature research of using current source in 2-dimensional and 3-dimensional multifrequency electrical impedance tomography devices. J. Eng. Appl. Sci., 12: 587-592.

Aleksanyan, G.K., I.D. Shcherbakov, A.I. Kucher and V.V. Demyanov, 2017b. Experimental research the human body impedance in the chest area depending the frequency of the injected current. J. Eng. Appl. Sci., 12: 2129-2137.

Aleksanyan, G.K., N.I. Gorbatenko, V.V. Grechikhin, T.N. Phong and T.D. Lam, 2016. Application of natural and model experiment methodology in two-dimensional electrical impedance tomography. ARPN. J. Eng. Appl. Sci., 11: 5871-5875.

Anonymous, 2014. Precision, very low noise, low input bias current, JFET operational amplifiers AD8510/AD8512/AD8513. Analog Devices, Norwood, Massachusetts, USA.

Bertemes-Filho, P., B.H. Brown and A.J. Wilson, 2000. A comparison of the modified mirror type circuits. Physiol. Meas., 21: 1-6.

Brazovskiy, K.S., 2015. [Methods and technical means for assessing the functional state of the human brain based on electrical measurements]. MSc Thesis, Tomsk Polytechnic University, Tomsk, Russia. (In Russian).

- Brazovsky, K.S., Y.S. Pecker and A.I. Soldatov, 2015. Investigation of injecting current sources for electrical impedance tomography. *Med. Equip.*, 16: 18-21.
- Chizhma, S.N., 2012. *Electronics and Microcircuitry: Studies*. Federal State Budget Educational Establishmen, Moscow, Russian, Pages: 359.
- Kulikov, G.B., 2010. *Life Safety*. Moscow State University of Printing Arts, Moscow, Russia, Pages: 408.
- Titze, U. and K. Schenk, 1982. *Semiconductor Circuit Design: Reference Guide*. Mir Publisher, Moscow, Russia, Pages: 512.