

Quasi-Z-Source Inverter Based Grid Tied System: Performance Analysis and Reliability Assessment

¹A.P. Munshi, ²A.A. Munshi and ¹S.G. Kadwane

¹Department of Electrical Engineering, Yeshwantrao Chavan College of Engineering, Nagpur, India

²Department of Electrical Engineering, Rajiv Gandhi College of Engineering and Research, Nagpur, India

Key words: Quasi-Z-Source converter based Inverter (qZSI), shoot through state, pulse width modulation, failure rate, reliability

Abstract: To boost dc voltage, traditional boost converter may be used. But it has many disadvantages like dual stage converter, complexity in control and high losses. On the other side the quasi-Z-Source Converter (qZSC) is an alternative converter that can boost the input voltage. It has many advantages like single stage conversion, lesser losses, reduced component rating and size and providing continuous input current. Quasi-ZSC provides boost capability with single stage conversion which ultimately reduces the switching losses. Quasi-Z-Source Converter based inverter (qZSI) allows the shoot through state which is responsible for the boosting of the input voltage to the higher value and avoids the risk of damaging switches in converter circuit to make the circuit more reliable. Theoretical analysis of boosted voltage and control methods for the qZSI system are investigated in this study. Also, the reliability of the system is evaluated using failure rate models given in Military Handbook MILHDBK 217F.

Corresponding Author:

A.P. Munshi

Department of Electrical Engineering, Yeshwantrao Chavan College of Engineering, Nagpur, India

Page No.: 2678-2684

Volume: 15, Issue 13, 2020

ISSN: 1816-949x

Journal of Engineering and Applied Sciences

Copy Right: Medwell Publications

INTRODUCTION

With the increasing use of fossil fuels, they are on edge of extinction. Because of which the major concerns about the non-renewable energy sources are constant increase in fossil fuel prices, global warming damage to environment and ecosystem. Hence, the renewable energy sources are becoming more popular and are gaining more attention as an alternative to non-renewable energy sources^[1]. Amongst all the renewable energy sources, the solar energy can be assumed to be the most favorable energy source as compared to other types of energy sources such as wind, tidal, etc.^[2]. The output obtained from the solar PV system is unregulated DC of small capacity at the customer site at distribution voltage levels.

Therefore, DC-DC converters are used for boosting up of unregulated DC voltage obtained by the PV module to a regulated suitably higher voltage level to supply power to the load^[3]. Conventional Pulse Width Modulation (PWM) based inverters are of buck type inverters and require additional power stage to boost the voltage from the renewable source. For applications requiring both buck and boost power conversions, Z-Source Inverters (ZSI) based topology has been proposed earlier. But the control complexity is an issue when the ZSI is used in a back-to-back configuration due to the coupling of the inverter switching functions. Also, the total harmonic distortion obtained is high^[4]. Therefore, the advanced topology, quasi-Z-source based grid connected system is to be investigated over conventional methodologies^[5].

In case of ZSI impedance source network, the sine PWM (SPWM) does not retain its symmetrical nature due to the addition of a shoot-through state which generates lower order harmonics. In this study, the concept of symmetrical shoot-through based PWM is explained in which sinusoidal shoot-through state is additionally inserted, so as to preserve the sinusoidal nature of the SPWM which further reduces the THD of the voltage waveform generated at the output^[6]. De-coupled control ensures nearly independent control of the DC side controller and AC side controller. The DC side controller is used to track the maximum power point in photovoltaic generation^[7]. The AC side controller is used to regulate and feed the necessary power to the grid^[8]. In this study, using a symmetrical shoot through based PWM the quasi-Z-source based grid tied inverter is investigated from performance point of view and the reliability of qZSI is evaluated over a period of one year using component reliability method.

Military hand book published by Defense Department of US, provides the basic data for calculation of failure rates (λ) of different electronic components. The reliability of any *i*th component of the system, after the duration of one year can be found using following formula^[9]:

$$R_i(t) = e^{-(\lambda \times 1 \times 24 \times 365)} \quad (1)$$

PROPOSED QUASI-Z-SOURCE CONVERTER BASED GRID TIED INVERTER SYSTEM

The proposed scheme, qZS converter is shown in Fig. 1. It is similar to voltage source inverter with the only difference that it consists of qZS impedance network

connected after the DC source. The impedance network is the combination of capacitors (C_1, C_2), inductors (L_1, L_2) and diode D_1 .

Unlike the traditional voltage source or current source inverter, the q-Z-source inverter has a unique impedance network. This LC impedance network is coupled with an inverter which boosts output capability of the qZSI. The single phase qZSI consists of five switching states given as follows:

- Two active states
- Two zero states and
- One shoot through state

Out of these, the shoot through is the unique state which is responsible for the buck-boost capability of qZSI. The shoot-through state is not applicable in the traditional VSI because it would cause short-circuit or damage to the system. With the help of LC network, the qZSI is capable to use the shoot through state to boost the voltage. In addition, with the ability to handle the shoot through state, the inverter system becomes more reliable. The impedance LC network protects the inverter from damage during the shoot-through state or during faulty condition. During shoot-through state the input voltage gets boosted to the higher values and it is controlled through the shoot-through signal.

During non-shoot-through state, the inverter operates normally as a traditional VSI where, the two opposite switches of an inverter operates simultaneously. Total time period (T) will be the sum of both shoot through state time (T_1) and non-shoot through state time (T_2). Shoot-through duty ratio D can be given as:

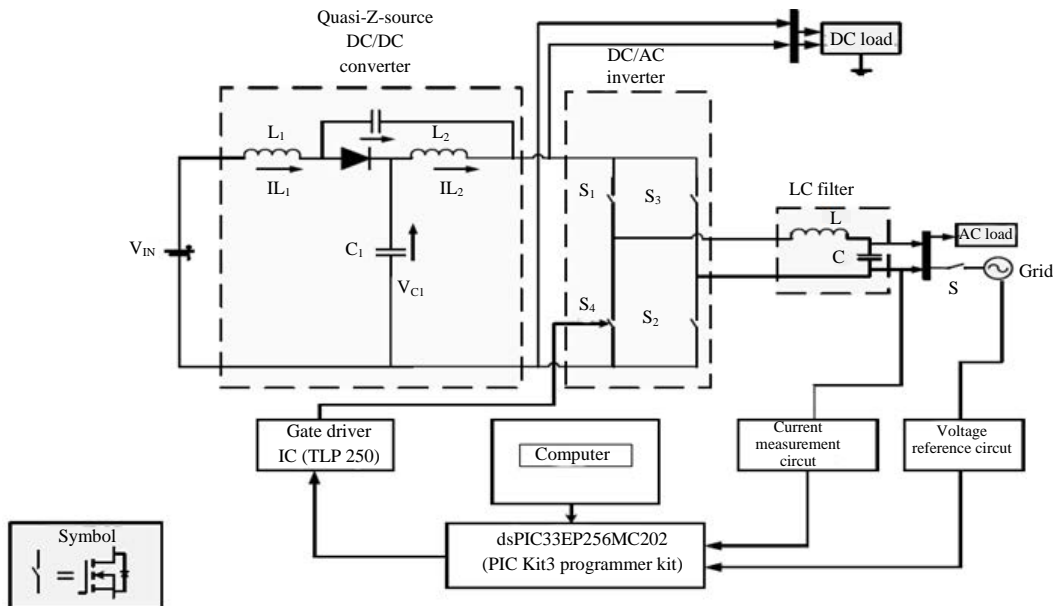

Fig. 1: System configuration for qZSI based grid connected system

$$D = \frac{T_1}{T} \quad (2)$$

MATHEMATICAL MODELLING OF QZSI

Figure 1 shows the system configuration of the proposed voltage-fed qZSI. It consists of a voltage-fed quasi Z-source network, a three phase inverter, a variable input voltage source and a switching logic controller. The battery energy storage system is connected in parallel with the capacitor. Since, the voltage stress of the capacitor is smaller, a relatively low-voltage battery with higher reliability, lower cost and longer lifetime can be used in the system. The three-phase inverter bridge and external AC load can be represented by a single switch and current source connected in parallel. Considering the asymmetric quasi-Z-source network, there are two switching states of the qZSI:

Shoot-through state: During shoot-through state, the ac load terminals will get a shoot-through in both upper and lower devices of any phase leg(s); meanwhile, the single switch is ON and the shoot-through ratio v equals to 1. The equivalent circuit for shoot through state is shown in Fig. 2. We get:

$$V_{L_1} = V_{C_2} + V_{in} \quad (3)$$

$$V_{L_2} = V_{C_1} \quad (4)$$

$$V_{DC} = 0 \quad (5)$$

Non-shoot-through state: When operating at non-shoot-through states ($v = 0$), the single switch is OFF and the shoot-through ratio v equals to 0. Figure 3 shows the equivalent circuit for non-shoot through state. We get:

$$V_{L_1} = -V_{C_1} + V_{in} \quad (6)$$

$$V_{L_2} = -V_{C_2} \quad (7)$$

$$V_{DC} = V_{C_1} - V_{L_2} = V_{C_1} + V_{C_2} \quad (8)$$

At steady state the average voltage across the both inductors over one switching cycle is zero. From Eq. 3-8, we get:

$$V_{L_1} = \frac{T_1(V_{C_2} + V_{in}) + T_2(V_{in} - V_{C_1})}{T} = 0 \quad (9)$$

$$V_{L_2} = \frac{T_1(V_{C_1}) + T_2(-V_{C_2})}{T} = 0 \quad (10)$$

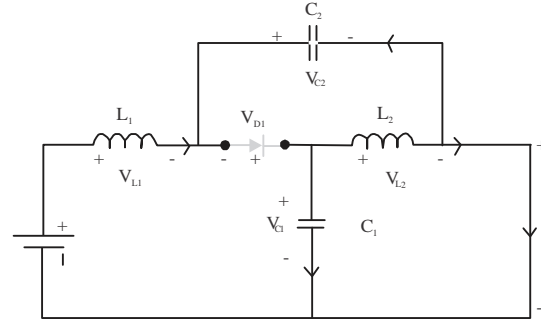

Fig. 2: Equivalent circuit for shoot through state

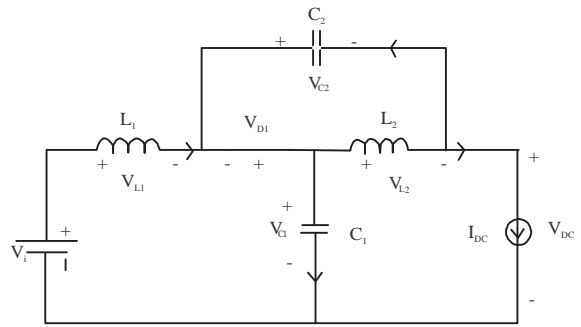

Fig. 3: Equivalent circuit for non-shoot through state

Now by solving (Eq. 9) and (10), we get:

$$V_{C_1} = \frac{T_1}{T_1 - T_2} V_{in} \quad (11)$$

$$V_{C_2} = \frac{T_2}{T_1 - T_2} V_{in} \quad (12)$$

The DC link voltage is given by:

$$V_{DC} = V_{C_1} + V_{C_2} = \frac{T}{T_1 - T_2} V_{in} \quad (13)$$

$$V_{DC} = \frac{1}{1 - 2D} V_{in} \quad (14)$$

where, D is duty cycle:

$$V_{DC} = B \times V_{in} \quad (15)$$

where, B is BOOST factor of qZSI. The new suggested PWM control strategy has a carrier wave which is split into two waveforms and then the shoot through state is created by using space between these two waveforms. These shoot-through states are symmetrical to the active state of sinusoidal PWM and therefore, preserve the

sinusoidal nature of the waveform. This unique method of generating symmetrical shoot-through state has good control in closed loop control as compared to the previous simple boost control method.

CONTROL STRATEGY

The specifications of the circuit used for the simulation are given in Table 1. As the input DC voltage is not constant in nature, the DC side control loop consists of a DC link voltage in order to maintain a constant voltage across the inverter. The qZ-source capacitor voltage which is input to the inverter needs to be regulated in order to regulate the DC link voltage (Fig. 4 and 5). The variation in load voltage is happened because there are variations in DC link voltage, these variations in

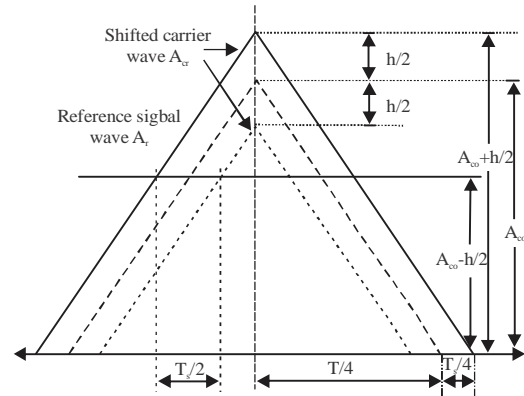

Fig. 4: Logic diagram for generation of a modulating signal pulses

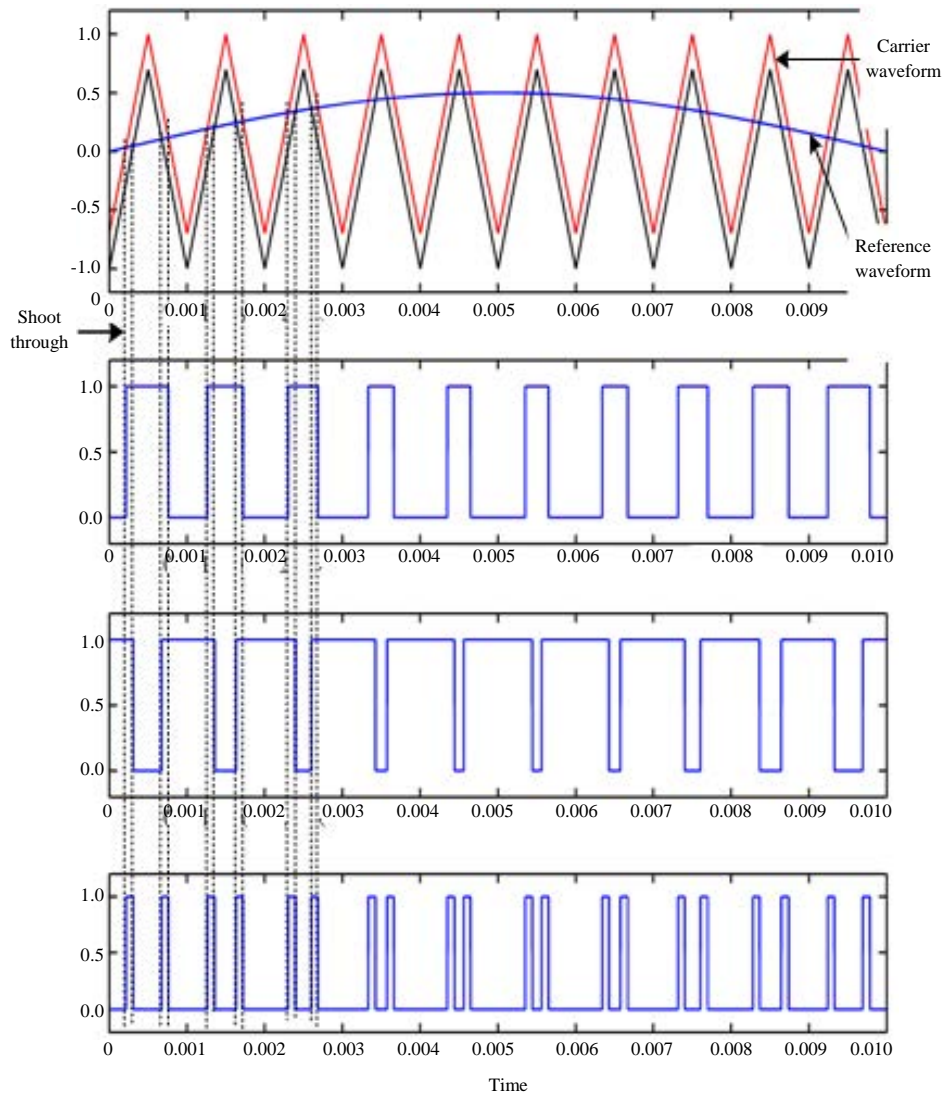

Fig. 5: Waveform of SST showing sinusoidal pattern and shoot-through states

Table 1: Parameter values of proposed scheme

Parameters	Values
Grid voltage	230 V (rms)
Grid frequency	50 Hz
Switching frequency	10 kHz
Current limiting inductor	10 Mh
qZ-source inductor ($L_1 = L_2 = L$)	170 μ H
qZ-source capacitor ($C_1 = C_2 = C$)	1000 μ F

the DC link voltage will occur due to change in input DC voltage. Thus, the DC link voltage must be regulated. For this, the qZ-source capacitor voltage is taken as the controlling quantity. This voltage is compared with a reference value and this error quantity is given to the PI controller which eventually, generates the modulation signal for inserting the shoot-through in, the zero states. Thus, the DC link voltage is controlled effectively by modulation of the shoot-through duty ratio. The AC side control loop involves the control of AC side voltage with reference generation for generating the modulating signal. This control involves a comparison of the output voltage with a reference voltage and this compared output is given to a PI controller to generate the modulating signal for the generation of PWM signals.

The logic diagram for the generation of a modulating signal pulses is shown in Fig. 4. The shift h in a carrier wave is provided by DC side controller and the modulating signal M is provided by the AC side controller.

The two carrier signals are in upward and downward directions, respectively which are shifted by a value of $h/2$ each using the summing amplifier. Upward shifted carrier is compared with modulating signal to produce a PWM signal of first leg upper switching device S_1 and the complement of this signal provide the PWM signal of second leg upper switching device S_3 . Similarly, downward shifted carrier waveform is compared with M (modulating signal) to produce PWM signals of lower switching devices S_2 and S_4 . Hence, necessary shoot-through states are produced by using this shifted carrier approach logically. Figure 5 shows the generation of symmetrical sinusoidal pattern and shoot through states in the waveform.

SIMULATION RESULTS

System ought to be directed regardless of whether the input of the system is varying which is as shown in the Fig. 6, the input is changed from 250-300 V and the capacitor waveform indicates that it is regulated at 400 V and network grid voltage and current is static, i.e., not changed. This can be useful in the event where, we utilize renewable sources as an input where time or climate

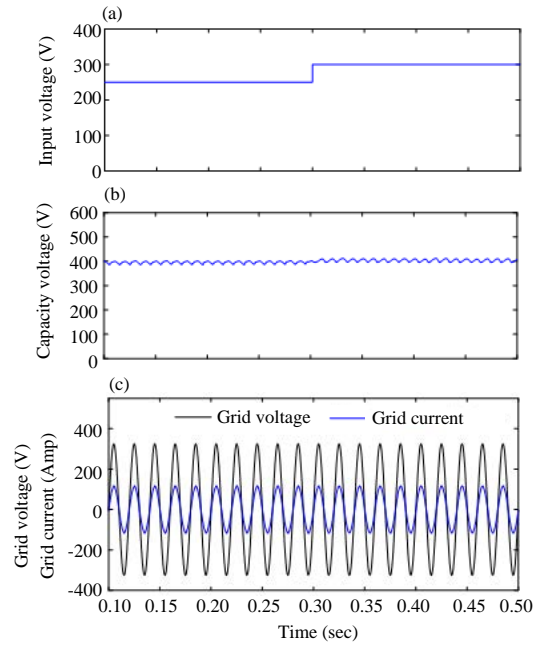

Fig. 6(a-c): Simulation result for step change in voltage from 250-300 V, (a) Input voltage, (b) Capacitor voltage and (c) Grid voltage and current (scaled by $\times 10$)

changes the input. At the point, when input changes the PI controller to adjust the shoot-through duty ratio keeping in mind the end goal to get a similar output voltage regardless of whether an input is changing.

Now in this case, the input is not changed but the regulation of the capacitor is changed from 400-500 V at 0.3 sec. As PI controller is used for DC side regulation, it does a quick regulation and the capacitor voltage is changed w.r. to the reference voltage within a fraction of seconds. In general, the reference change does not occur in practical.

But in case of any fault in the system, the capacitor voltage needs to gain the required regulating voltage. Results are shown in Fig. 7.

As the system is grid connected, there are many loads concerned with the system domestically or externally. In this case domestic load has been changed at 0.3 sec. As load has been decreased, less current is drawn from the system.

Therefore, the grid current gets increased from 5-10 A as 5 A is flowing through the load. In case if the system is practically connected to the grid, the current control in AC side should be proper in order maintain the power flow in the system as shown in Fig. 8.

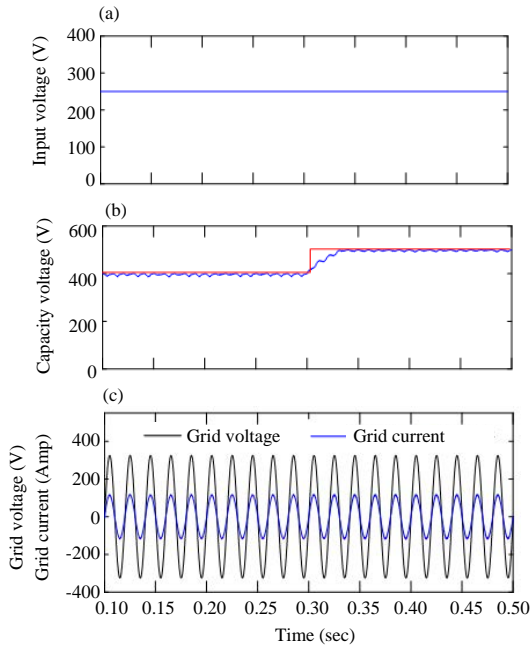

Fig. 7(a-c): Simulation result for step change in capacitor voltage from 400-500 V, (a) Input voltage, (b) Capacitor voltage and (c) Grid voltage and current (scaled by×10)

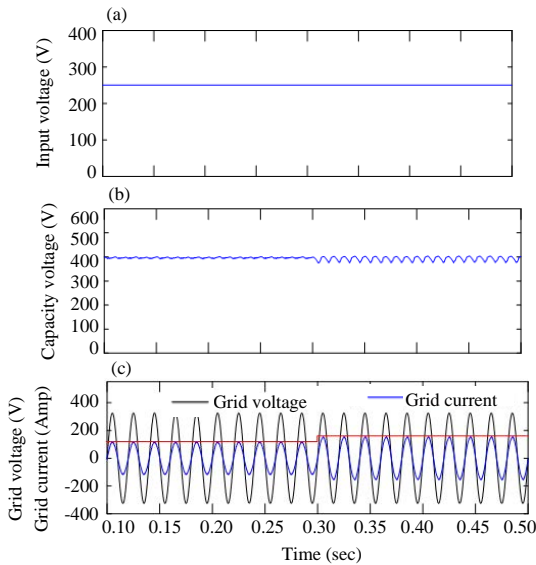

Fig. 8(a-c): Simulation result for step change in current from 5-10 A, (a) Input voltage, (b) Capacitor voltage and (c) Grid voltage and current

RELIABILITY EVALUATION OF QZSI

Reliability of a system or equipment or circuit is an important feature to get an uninterrupted service. The reliability block diagram of the system given in Fig. 1 is

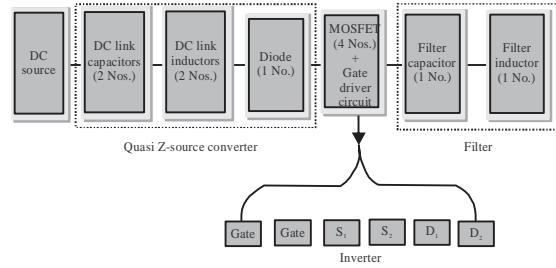

Fig. 9: Reliability block diagram of qZSI

Table 2: Failure rate models of corresponding components

Components	Failure rate models	Value×10 ⁻⁶ (Failures/h)
Capacitor	$\lambda_c = \lambda_{c,b}\pi_f\pi_c\pi_s\pi_{sr}\pi_q\pi_e$	0.4860
Inductor	$\lambda_L = \lambda_{L,b}\pi_f\pi_q\pi_e$	0.0129
MOSFET	$\lambda_s = \lambda_{s,b}\pi_f\pi_A\pi_q\pi_e$	0.7392
Diode	$\lambda_D = \lambda_{D,b}\pi_f\pi_{CC}\pi_s\pi_q\pi_e$	0.0418
Filter capacitor	$\lambda_{CF} = \lambda_{CF,b}\pi_C\pi_q\pi_e$	0.7701
Filter inductor	$\lambda_{Lf} = \lambda_{Lf,b}\pi_C\pi_q\pi_e$	0.0317

Table 3: Total failure rates of corresponding components

Component	No. of components used	Total failure rate×10 ⁻⁶ (Failures/h)
Quasi Z source converter		
Inductor (L)	2	$\lambda_L = 0.0258$
Capacitor (C)	2	$\lambda_c = 0.9721$
Diode (D)	1	$\lambda_D = 0.0418$
Inverter		
MOSFET (S)	4	$\lambda_s = 0.4622$
Filter		
Filter capacitor (Cf)	1	$\lambda_{CF} = 0.7701$
Filter inductor (Lf)	1	$\lambda_{Lf} = 0.0317$

Table 4: Overall failure rate and reliability of the system

λ_{qZSI}	2.3037×10 ⁻⁶ (Failures/h)
Reliability	98.00%

presented in Fig. 9 considering that all the components are connected in series, since, the failure of any single component may reduce the reliability to zero making the overall system to shut down.

The overall reliability is calculated based on^[9] where the failure rates and other values are calculated from the military handbook MILHDBK-217F. The Failure rate models and the values of failure rates of different individual components are mentioned in Table 2. Table 3 presents the total failure rates of corresponding components of the system.

The total failure rate of the overall system is the summation of all individual failure rates of the corresponding components. The overall reliability of the system is then evaluated using (Eq. 1). For the system represented in Fig. 9, the overall failure rate and overall reliability is evaluated and is given in Table 4.

CONCLUSION

A symmetrical shoot through based PWM method for a quasi-Z-source inverter has been investigated and

presented in this study. From simulation results it is found that by inserting a symmetrical shoot through state using PWM the total harmonic distortion has been reduced as compared to the existing PWM methods. This study also demonstrates, a simple carrier shifting method for the implementation of this symmetrical shoot through PWM. The quasi-Z source based inverter topology presented in this study provides several advantages when compared to the traditional Z-Source Inverter (ZSI). These advantages include reduction of passive component ratings, reduced component count and improved input efficiency of the system. From the reliability evaluation, it is clear that the proposed topology is as reliable as ZSI and can prove to be a better option to it owing to its several other advantages mentioned above.

REFERENCES

01. Park, J.H., H.G. Kim, T.W. Chun, E.C. Nho, H.J. Shin and M.H. Chi, 2008. A control strategy for the grid-connected PV system using a Z-source inverter. Proceedings of the 2008 IEEE 2nd International Power and Energy Conference, December 1-3, 2008, IEEE, Johor Bahru, Malaysia, pp: 948-951.
02. Dijk, E.V., J.N. Spruijt, D.M. O'sullivan and J.B. Klaassens, 1995. PWM-switch modeling of DC-DC converters. IEEE. Trans. Power Electron., 10: 659-665.
03. Peng, F.Z., M. Shen and Z. Qian, 2005. Maximum boost control of the Z-source inverter. IEEE Trans. Power Electr., 20: 833-838.
04. Siwakoti, Y.P., F.Z. Peng, F. Blaabjerg, P.C. Loh and G.E. Town, 2014. Impedance-source networks for electric power conversion part I: A topological review. IEEE. Trans. Power Electron., 30: 699-716.
05. Peng, F.Z., 2003. Z-source inverter. IEEE Trans. Ind. Applic., 39: 504-510.
06. Liu, Y., B. Ge, H. Abu-Rub and F.Z. Peng, 2013. An effective control method for quasi-Z-source cascade multilevel inverter-based grid-tie single-phase photovoltaic power system. IEEE. Trans. Ind. Inf., 10: 399-407.
07. Cintron-Rivera, J.G., Y. Li, S. Jiang and F.Z. Peng, 2011. Quasi-Z-source inverter with energy storage for photovoltaic power generation systems. Proceedings of the 2011 26th Annual IEEE Applied Power Electronics Conference and Exposition (APEC), March 6-11, 2011, IEEE, Fort Worth, Texas, pp: 401-406.
08. Kadwane, S.G., U.K. Shinde, S.P. Gawande and R.K. Keshri, 2017. Symmetrical shoot-through based decoupled control of Z-source inverter. IEEE Access, 5: 11298-11306.
09. Kadwane, S.G. and N.M. Bansod, 2013. Reliability evaluation for stand alone photovoltaic generation system. Altern. Energy, Vol. 3, No. 1.