

Design and Performance Analysis of Double Axial Flux Permanent Magnet Generator

¹Eko Yohanes Setyawan, ²Choirul Soleh, ²Awan Uji Krismanto, ³Richard A.M. Napitupulu and ³Parulian Siagian

¹Department of Mechanical Engineering, National Institute of Technology Malang, Malang 65152, Indonesia

²Department of Electrical Engineering, National Institute of Technology Malang, Jl. Bendungan Sigurgura No. 2 Malang 65152, Indonesia

³Department of Mechanical Engineering, Nommensen HKBP University, Jl. Sutomo 4A Medan 20234, Indonesia

Key words: Double axial, permanent magnet, renewable energy, generator structure, facilitate implementation

Abstract: In this study, a novel permanent magnet generator structure is proposed in order to facilitate implementation of the permanent magnet generator on small scale renewable energy-based power generation. Detail characteristic of an double axial flux permanent magnet generator is analyzed. The proposed generator structure consists of two-sided rotor which equipped with slots for placing permanent magnet. The stator side is comprising of three groups of coreless winding for realizing three phase output. Performances of the axial flux double permanent magnet generator are observed involving the output voltage, currents and power. Two experimental scenarios have been tested to monitor the performance of the generator. In first scenario, loading condition which represented by star connection of three bulbs of 25 W has been considered. The rotational speed of the tested generator in this scenario is 501.9 rpm. It was monitored that under those loading circumstance, three phase sinusoidal output voltages with frequency under 50 Hz have been monitored. Moreover, above 50 Hz operational frequency, the output voltage waveform slightly changes from sinusoidal to trapezoidal shapes. In second scenarios, the proposed generator is connected to the rectifier to form a DC system. The 45 W load has been considered in this DC scenario. Under DC system test, 152.2 V output DC voltage, 0.1614 A current and 24.976 W power have been monitored when the rotational speed of axial flux double permanent magnet generator was 847.9 rpm.

Corresponding Author:

Parulian Siagian

Department of Mechanical Engineering, Nommensen HKBP University, Jl. Sutomo 4A Medan 20234, Indonesia

Page No.: 47-53

Volume: 16, Issue 1, 2021

ISSN: 1816-949x

Journal of Engineering and Applied Sciences

Copy Right: Medwell Publications

INTRODUCTION

The axial flux permanent magnet generator was invented around 150 years ago^[1]. The invented generator

structure has advantages such as higher power density, better cogging torque and simple construction resulting more efficient and cheaper manufacturing production^[2]. Moreover, axial flux type of generator ensures low

distortion and purely sinusoidal voltage output waveform^[3, 4]. From flux point of view, geometry structure of axial flux generator is the important features to increase power density^[5]. Effects of core shape, lamination, air-gap and core losses on efficiency of Axial Flux Permanent Magnet Generator (AFPMG) with FEA have been investigated. It was found that the dimension of magnetic core should be minimized in order to improve efficiency and generator performances^[6]. The increase of power output of the generator can be achieved by increasing the number of coils. Therefore, in order to increase the output power without significantly change the generator construction, it is preferable to use double-side rotor than single-side rotor configurations^[7].

Enhancement of generator performance can also be achieved by considering various configuration of the core. The core of the generator can be either slotted or slot-less which aims to reduce cogging torque and mitigate inductance losses, respectively^[8]. Moreover, interaction force between core and permanent magnet should be carefully considered to optimally reduce the cogging torque^[9]. Magnetic force in axial flux generator potentially introduces larger mechanical pressure and vibration to the machine due to larger air gap in axial flux generator than in radial flux generator^[7]. The air gap usually can be designed in between 1-4 mm with considering the mechanical process of the generator. It is important to be noted that the dimension of air gap influences the output of the generator^[10]. Therefore, optimization of air gap dimension should be conducted in design process of axial flux generator^[11]. In coreless type of rotor, the winding should be put into the non-magnetic material with isoelastic characteristic such as epoxy and polyamide. The coreless rotor type results in less weight of generator and the absence of core loss and cogging torque. On the other hand, the drawback of coreless type of generator is the increase of loss due to eddy current effect in the field winding under high speed operation of the generator^[11]. Lower magnetic fluxes which influence the efficiency of the generator also become a concern in coreless rotor type^[12]. The other factor that influence the generator characteristic is air gap. As previously mentioned, smaller air gaps would increase the output of generator. Conversely, higher air gap introduces more losses in generator^[13].

In comparison with radial flux, axial flux permanent magnet generator has low cogging torque and higher power density and efficiency^[14]. Higher power density in axial flux permanent magnet generator results in increase of operating temperature of the generator. Therefore, in axial flux generator, air gap design is important to reduce the operating temperature^[15, 16]. In order to achieve good generator performance in axial flux permanent magnet generator, stator and rotor design should be combined properly to reduce the power loss and increase the

efficiency^[6, 17]. Two side rotor design can be considered to increase the power output of generator. Since, the proposed design doubled the generator output power^[18]. In this paper, characteristic and performance of double side axial flux permanent magnet generator are analyzed. The proposed generator considers two side rotor design with permanent magnet. Moreover, in order to maintain power quality, the output of the generator is connected to rectifier to converse AC terms output into DC terms output.

MATERIALS AND METHODS

Design procedure of double side axial flux permanent magnet generator is depicted in Fig. 1. Design of double side rotor in proposed axial flux generator is depicted in Fig. 2. In this research, the dimension of generator has length of 45 cm length, width of 33 cm and height of 46 cm. The purpose of small size design of the generator is to facilitate flexibility, simple installation and portable features of the generator. The proposed rotor design incorporates double rotor type in the left and right of the stator. The rotors and stator are connected with a shaft hence it can rotate in similar speed and directions. In each side of the rotor, 12 permanent magnet of neodymium type with 50×15×6 mm dimension are installed. Hence, in the generator, there are 24 permanent magnets in the rotor side.

The stator side of the proposed permanent magnet generator is the copper winding with the number of winding is nine. Since, the output of the generator is three-phase, the windings are divided into three group. Each group is consisting of three winding. The conductor used in this design is copper conductor with 1 mm diameter. The number of turn in each winding is 300 turns. Moreover, the air gap between rotor and stator is determined as 4 mm. The stator design of double side axial flux permanent magnet generator is shown in Fig. 3.

The proposed design of double side axial flux permanent magnet generator has the efficient natural colling mechanism in the surface of stator and rotor. The configuration of permanent magnet is symmetric and parallel with the position of stator winding with pole orientation of N-S-N-S. The pole orientation of rotor is complementary each other.

Theoretical background: In three phase construction, the winding which is connected in series is further divide into three different groups. Each group represents one-phase output of the generator. It is compulsory to produce three identical output waveforms with similar phase angle to ensure a good quality of generator power output. Therefore, each group of winding should have identical shape, type of winding and number of turns. Total inductance in each phase can be stated as follows:

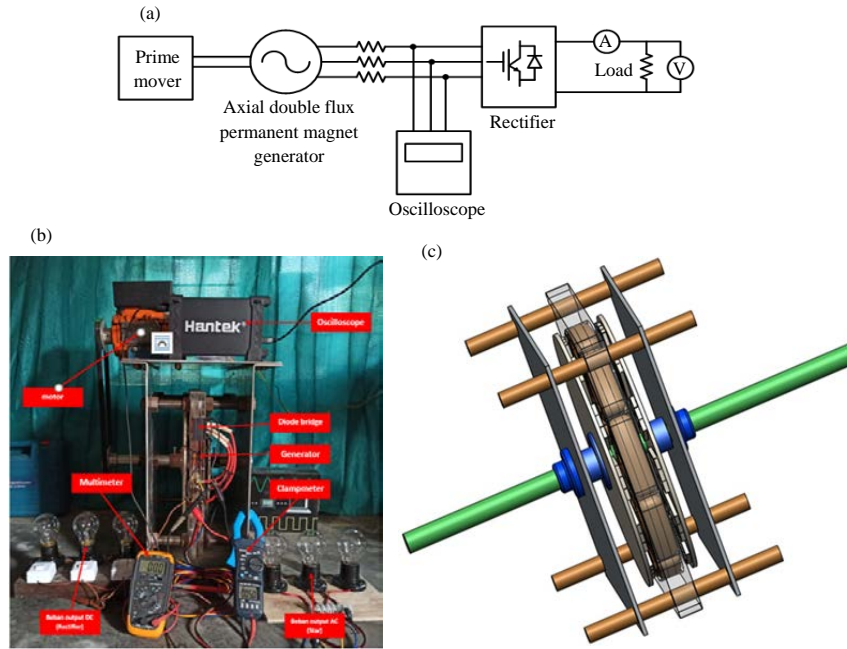

Fig. 1(a-c): Design and experimental setup of double side axial flux permanent magnet generator, (a) Diagram of proposed double side axial flux permanent magnet generator, (b) Experiment setup of double side axial flux permanent magnet generator and (c) The design of double side axial flux permanent magnet generator

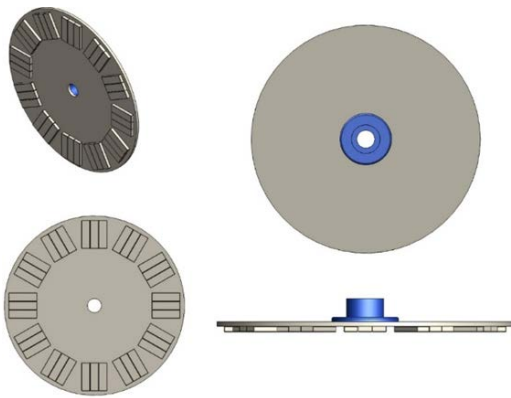

Fig. 2: Design of double side rotor in proposed axial flux generator

$$L_{\text{phase}} = L_1 + L_2 + L_3 + \dots + L_n \quad (1)$$

Where:

- L_{phase} = A total inductance in each phase
- $L_1 + L_2 + \dots + L_n$ = Inductance values in each winding
- n = The number of winding connected in series in single phase

Involving the terminal output voltage in each phase, load voltage and voltage drop along the winding, the voltage relationship in each phase can be represented using the following equation

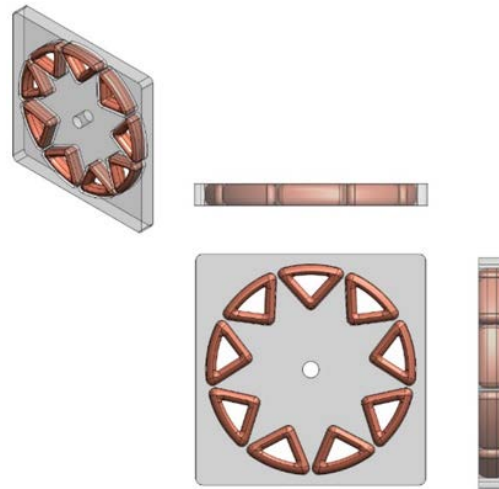

Fig. 3: Stator design of double side axial flux permanent magnet generator

$$V_{\text{phase}} - V_{R_{\text{phase}}} - V_{L_{\text{phase}}} = 0 \quad (2)$$

where V_{phase} is phase voltage. While $V_{R_{\text{phase}}}$ and $V_{L_{\text{phase}}}$ represent load voltage and voltage drop of the winding respectively. Equation 2 can be written as a function of currents and impedance as follows:

$$\frac{di_A}{dt} = \frac{i_A}{L_{pA}} (R_A + R_{LA}) \quad (3)$$

Where:

i_A = Phase current
 L_{pA} = The total impedance of each phase
 R_A and R_{LA} = The load and winding resistance, respectively

Induction voltage in each phase is stated using the Eq. 4:

$$V_{LpA}(t) = -3N \frac{d\phi(t)}{dt} \quad (4)$$

where the coefficient of 3 represents number of group winding that are connected in similar phase and N represents number of turns in each winding. The power output of the generator is stated as follows

$$P_{out} = 3V(t).i(t) \quad (5)$$

where, $V(t)$ dan $i(t)$ dan represent the instantaneous voltage and current, respectively. The power factor is assumed as unity power factor.

In balance multi-phase system, the total output power can be determined by multiplying the single-phase output with the coefficient number which represent the number of phases. Hence, the total output power in multi-phase system is stated as follows:

$$P_{out} = m.V(t).i(t) \quad (6)$$

where, m represents the number of output phase. As previously mentioned, power losses in generator is comprising of copper losses in the winding, core loss in permanent magnet and mechanical loss^[8, 15]. As the main windings are located in stator, the power losses depend on the design of the stator. The total copper loss can be stated using the Eq. 7:

$$P_{cu} = m.i(t)^2.R_p \quad (7)$$

In general, core loss is consisting of hysteresis, eddy current and anomalous losses^[19]. The core losse can be presented as follows:

$$P_{Fe} = P_h + P_e + P_a \quad (8)$$

$$P_h = k_h \frac{f}{50} B_{pk}^{1.8} W_{Fe} \quad (9)$$

$$P_e = k_e \left(\frac{f}{50} B_{pk} \right)^2 W_{Fe} \quad (10)$$

$$P_a = k_a \left(\frac{f}{50} B_{pk} \right)^{1.5} W_{Fe} \quad (11)$$

Where:

P_e, P_{Fe}, P_h and P_a = Eddy current, core, hysteresis and anomalous losses, respectively
 W_{Fe} = Representing core mass, represents the peak of flux density in Tesla
 k_a, k_e and k_h = Coefficient constant of anomalous loss, eddy loss and hysteresis loss, respectively

According to the previous equations, the total efficiency of the generator can be stated as:

$$\eta = \frac{P_{out}}{P_{out} + \Delta P} \times 100 \quad (12)$$

Where is the total loss of the generator.

RESULTS AND DISCUSSION

The performances of proposed axial flux double permanent magnet generator are presented. The AC side output of the generator and the DC side output after rectification process are analyzed. First experimental setup considers a loading condition with three 25 W resistive loads connected in star configuration. The waveforms of the terminal voltage at the output AC side of the generator before rectification process are monitored to assess the quality performance of the generator. Table 1 represent the monitoring results of the AC side generator terminal voltages. It was observed that the phase voltages of the generator have relatively similar magnitude values. The small difference of those magnitude values can be caused by some factors such as the shape of coil which is not perfectly identic, non-uniform air gap distance which results in fluctuating effects of inductance values between permanent magnet and coil. Moreover, it was monitored that terminal voltage of the generator is increasing proportionally with the increase of the rotational speed. As the speed is increasing, the frequency output of the generator also increased. It was monitored that the proposed generator can be operated in utility frequency (50 Hz) with 501.9 rpm rotational speed.

Figure 4 represents the three phase AC side voltage waveform of the axial double flux permanent magnet generator. It was monitored that in 240 rpm rotational speed, the waveform of the AC side output voltage is purely sinusoidal with the operating frequency is 20.5 Hz. Moreover, the voltage magnitude of phase R is 17.4 Volt, phase S 16 Volt and phase T is 17 Volt. Figure 5 represents the three phase AC side voltage waveform of the axial double flux permanent magnet generator when it was operated in 417.2 rpm rotational speed. Similarly, it was monitored that the waveform of the AC side output voltage is purely sinusoidal with the operating frequency

Table 1: Measurement of the output voltage of each generator phase

RPM	R-N (V)	S-N (V)	T-N (V)	Frequency (Hz)
204	17.4	16.0	17.0	20.5
305.8	25.9	23.7	25.3	30.5
417.2	32.7	29.9	32.2	41.4
501.9	39.7	36.1	38.7	50.1
612.7	48.7	44.5	47.6	60.9
718.7	56.1	51.1	54.7	70.5
807.7	63.3	57.6	61.7	80.5
894.2	71.7	65.5	70.1	90.0
1010.4	81.2	74.1	79.4	100.7
1141.7	89.1	81.3	87.1	110.7

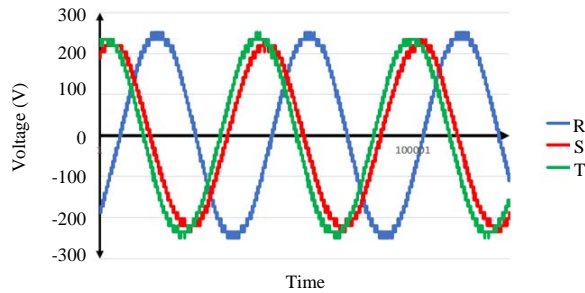

Fig. 4: Three phase voltage output at frequency of 20.5 Hz

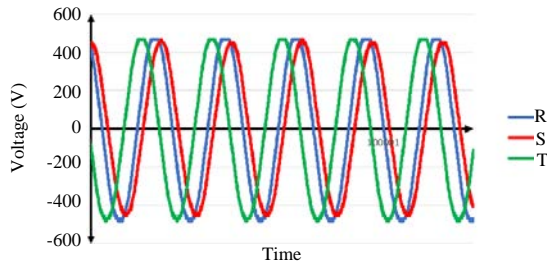

Fig. 5: Three phase voltage output at frequency of 41.4 Hz

is 41.4 Hz. Moreover, the voltage magnitude of phase R is 32.7 Volt, phase S 29.9 Volt and phase T is 32.2 Volt. Figure 6 shows the three phase AC side voltage waveform of the axial double flux permanent magnet generator under 501.9 rpm rotational speed. In this rotational speed, operating frequency of the generator is 50.1 Hz, similar to the fundamental frequency of the utilities.

Therefore, it can be observed that the proposed axial double flux permanent magnet generator can be synchronized with grid within this rotational speed. The waveform of the AC side output voltage is purely sinusoidal. Moreover, the voltage magnitude of phase R is 39.7 Volt, phase S 26.1 Volt and phase T is 38.7 Volt. As the rotational speed is continuously increased to 612.7 rpm, the operational frequency becomes 60.1 Hz. The waveform of the generator terminal voltages is changing into trapezoidal form as presented in Fig. 7

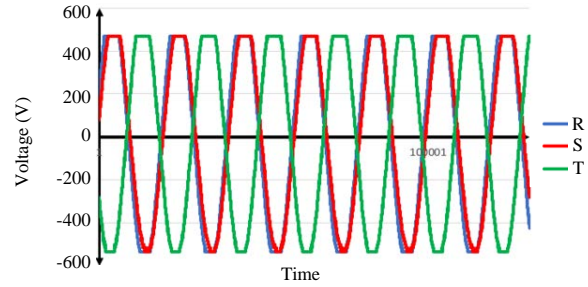

Fig. 6: Three phase voltage output at frequency of 50.1 Hz

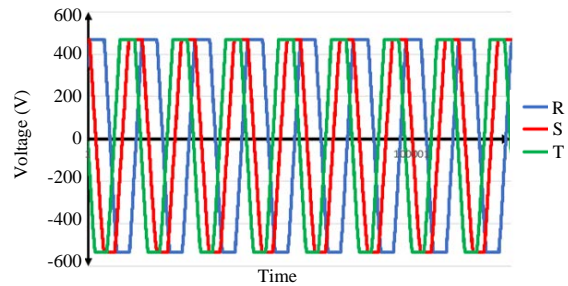

Fig. 7: Three phase voltage output at frequency of 60.9 Hz

with the magnitude of phase voltage is 48.7 Volt for phase R, 44.5 Volt for phase S and 47.6 Volt for phase T.

As depicted in Fig. 4-7, it was clearly observed that there are some concerns regarding the terminal output voltage of the generator. The phase angle among phase voltage are not equal. In ideal condition, the phase voltage should be separated by 120° each other. However, the obtained results indicated unbalanced condition of phase shift among those three phase voltages. The unbalanced in the phase voltages disturbs the current waveform significantly and deteriorating the power quality. Moreover, as rotational speed is increased, more deviation and distortion of voltage waveform are monitored, indicated by change of voltage waveform from purely sinusoidal to trapezoidal shapes. The distorted voltage and current waveform increased the harmonic content in the system. High harmonic content would result in the increase of losses and heating problems. With those concerns, it is not allowable to directly connect the AC side terminal voltage of the proposed axial flux permanent magnet generator to the load. To solve the problem, it is required to improve the power quality and reduce the distortion of AC side terminal voltages. Among several options such as connecting additional low pass filter at AC side of the generator and drastically change the construction of the generator, it is preferable to convert the distorted AC form into free-distortion DC form voltage and current. Therefore, in this study, the AC side terminal generator is connected to full bridge rectifier to obtain the DC voltage and current.

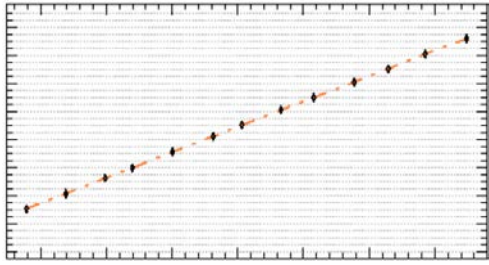

Fig. 8: Correlation between rotational speed and DC voltage

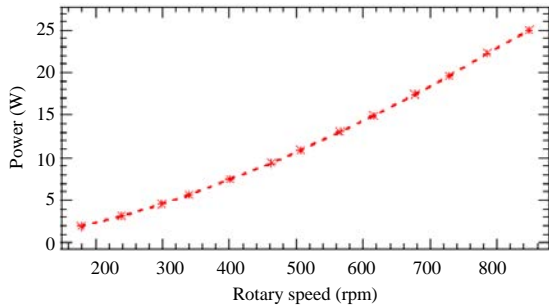

Fig. 9: Correlation between output power and rotational speed

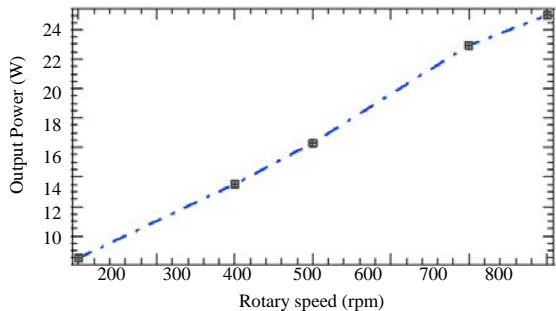

Fig. 10: Correlation between output power and rotational speed

To analyze the performance of the proposed generator and coupling full bridge rectifier, two experimental setups are considered. The first experimental setup considers a loading condition with a bulb of 45 W is considered. Figure 8 depicts the correlation between rotational speed and DC voltage. From the graph, it was observed that the DC voltage is increasing proportionally with the increase of rotational speed.

Higher rotational speed results in higher DC voltage. Consequently, as the DC voltage is increasing with the increase of rotational speed, the power output the current also proportionally increasing as depicted in Fig. 9. The

second study case is analyzing the generator performance under load variation scenario. The connected load is increasing gradually from 15-45 W with the constant rotational speed of 840 rpm. The output power is continuously increasing with the increase of connected load. At loading condition of 15 W, the output power is 8.514 W, at 25 W loading condition the measured output power is 13.520. Under 30 W and 40 W loading circumstances, the output power of the generator are 16.314 and 22.948 W, respectively. Finally, at 45 W of load, the measured output power is 45 W. The correlation between output power as the function of load is depicted in Fig. 10.

CONCLUSION

Design and experimental assessment of axial double flux permanent magnet generator is presented in this study. The experimental results suggest that the AC side terminal voltage of the proposed generator has the unbalance phase shift and high distortion when it was operated in higher rotational speed. To overcome the problem, the proposed generator is connected with a full bridge rectifier to generate DC form voltage and output power. From the experimental results, it was clearly monitored that the voltage of the generator can be increased by increasing the rotational speed. Therefore, the voltage can be controlled and regulated by adjusting the rotational speed of the generator.

REFERENCES

01. Sadeghierad, M., H. Lesani, H. Monsef and A. Darabi, 2009. Detail modeling of high speed axial flux pm generator. *Aust. J. Basic Applied Sci.*, 3: 1467-1475.
02. Barave, S.P. and B.H. Chowdhury, 2009. Optimal design of induction generators for space applications. *IEEE. Trans. Aerospace Electron. Syst.*, 45: 1126-1137.
03. Kurt, E., S. Aslan and M. Demirtas, 2012. Cogging torque exploration of radially and angularly directed fluxes in a new PM generator with the multiple stators. *Proceedings of the 7th International Conference & Exhibition Ecological Vehicles and Renewable Energies (EVER'12) Vol. 12, March 22-25, 2012, Gouvernement Princier, Monaco*, pp: 1-5.
04. Kurt, E. and H. Gor, 2014. Electromagnetic design of a new axial flux generator. *Proceedings of the 2014 6th International Conference on Electronics, Computers and Artificial Intelligence (ECAI), October 23-25, 2014, IEEE, Bucharest, Romania*, pp: 39-42.

05. Vansompel, H., P. Sergeant, L. Dupre and A. Van den Bossche, 2013. Axial-flux PM machines with variable air gap. *IEEE. Trans. Ind. Electron.*, 61: 730-737.
06. Price, G.F., T.D. Batzel, M. Comanescu and B.A. Muller, 2008. Design and testing of a permanent magnet axial flux wind power generator. *Proceeding of the 2008 IAJC-IJME International Conference*, November 17-19, 2008, Sheraton Music City Hotel, Nashville, Tennessee, pp. 1-15.
07. Sung, S.Y., J.H. Jeong, Y.S. Park, J.Y. Choi and S.M. Jang, 2012. Improved analytical modeling of axial flux machine with a double-sided permanent magnet rotor and slotless stator based on an analytical method. *IEEE. Trans. Magn.*, 48: 2945-2948.
08. Chalmers, B.J. and E. Spooner, 1999. An axial-flux permanent-magnet generator for a gearless wind energy system. *IEEE. Trans. Energy Convers.*, 14: 251-257.
09. Aydin, M. and M.K. Guven, 2013. Design of several permanent magnet synchronous generators for high power traction applications. *Proceedings of the 2013 International Electric Machines & Drives Conference*, May 12-15, 2013, IEEE, Chicago, Illinois, pp: 81-87.
10. Sadeghierad, M., H. Lesani, H. Monsef and A. Darabi, 2007. Design considerations of high speed axial flux permanent magnet generator with coreless stator. *Proceedings of the International Power Engineering Conference*, December 3-6, 2007, IEEE Xplore, London, pp: 1097-1102.
11. Nguyen, T.D., K.J. Tseng, S. Zhang and H.T. Nguyen, 2010. A novel axial flux permanent-magnet machine for flywheel energy storage system: Design and analysis. *IEEE. Trans. Ind. Electron.*, 58: 3784-3794.
12. Wang, R.J. and M.J. Kamper, 2004. Calculation of eddy current loss in axial field permanent-magnet machine with coreless stator. *IEEE. Trans. Energy Convers.*, 19: 532-538.
13. Chen, Y., P. Pillay and A. Khan, 2004. PM wind generator comparison of different topologies. *Proceedings of the Joint Conference Record of the and 39th IAS Annual Meeting on IEEE Industry Applications Conference Vol. 3*, October 3-7, 2004, IEEE, Seattle, Washington State, pp: 1405-1412.
14. Al-Aawar, N., T.M. Hijazi and A.A. Arkadan, 2010. Design optimization of axial-flux permanent magnet generator. *Proceedings of the Digests of the 2010 14th Biennial IEEE Conference on Electromagnetic Field Computation*, May 9-12, 2010, IEEE, Chicago, Illinois, pp: 1-1.
15. Bumby, J.R. and R. Martin, 2005. Axial-flux permanent-magnet air-cored generator for small-scale wind turbines. *IEE Proc. Electr. Power Appl.*, 152: 1065-1075.
16. Chan, C.C., 1987. Axial-field electrical machines-design and applications. *IEEE. Trans. Energy Convers.*, 2: 294-300.
17. Patterson, D. and R. Spee, 1995. The design and development of an axial flux permanent magnet brushless DC motor for wheel drive in a solar powered vehicle. *IEEE. Trans. Ind. Appl.*, 31: 1054-1061.
18. Chan, T.F., W. Wang and L.L. Lai, 2012. Magnetic field in a transverse-and axial-flux permanent magnet synchronous generator from 3-D FEA. *IEEE. Trans. Magn.*, 48: 1055-1058.
19. Chan, T.F., L.L. Lai and S. Xie, 2009. Field computation for an axial flux permanent-magnet synchronous generator. *IEEE. Trans. Energy Convers.*, 24: 1-11.