

The Design of the Conceptual Model of the Factors Affecting Labor Productivity in Iran's Sport Federations

¹Samaneh Rastgou, ¹Seyedeh Ozra Mir Kazemi,
²Muhammad Kharashadi Zadeh and ¹Reyhaneh Parhiz

¹Department of Physical Education and Sport Sciences, Faculty of Physical Education,

²Department of Statistics, Faculty of Statistics,
University of Birjand, Birjand, Iran

Abstract: Without a doubt, in today's competitive world, the condition of survival in any organization is improving labor productivity. Labor (human resource) plays a key role in this area and is of great importance as a valuable source for organizations. The purpose of the present study is to study labor productivity and present the conceptual model of effective factors. The statistical population of this study included all staffs in Iran's sport federations ($n = 1394$). According to Morgan's table, 302 subjects were selected as samples by stratified random sampling method. The content validity and construct validity of the research instrument were respectively confirmed by Expert Panel method and exploratory confirmatory factor analysis. Cronbach's alpha test was used to measure the reliability. The ($\alpha = 0/98$) labor productivity was obtained by using the productivity scores of each federation and putting them in the formula of labor productivity. The $(P_L) = (P_T \div T_w) \times P_w$. Then, the factors affecting productivity were identified by a questionnaire and the effectiveness rate of each one on sport federation's labor productivity was studied according to structural equations by Amos Software. The results of statistical analyses showed that the rate of labor productivity in federations is at an optimal and favorable level. Using this instrument and the results of the proposed conceptual model can improve the effectiveness and efficiency of staff's employees.

Key words: Labor productivity, factors affecting labor productivity, structural equations, sport federations, Iran

INTRODUCTION

Today, the importance of productivity is obvious due to the development of competition, technological complexities, variety of interests and tastes, shortage of resources and speed of information exchange. The most valuable place is given to productivity by measures and everyone looks for more efficiency and effectiveness in order to guarantee the stability of organizations in today's competitive world. Since, the most important factor affecting labor productivity in any organization is labor or human resource and this variable is one of the main variables in determining productivity in any country, the most successful organizations and developed countries should pay enough attention to this factor (Jones *et al.*, 2006). Thus, the identification of the factors affecting labor productivity and performance is of great importance. Bahadori *et al.* (2013) in this regard in sport organizations, labor productivity is one of the mechanisms that should be continuously regarded by organization and the factors affecting their productivity

should be recognized. Mohammadi *et al.* (2014) according to the place and importance of sport federations in Iran and their important and valuable tasks such as the development and promotion of sport at public (general) and elite levels, coordination of competitions at local and national levels, selection, training and development of national teams to attend international fields and on the other hand their dependence on the state's financial resources to provide services and perform their plans to have accountability for their performance. Thus, one of the effective ways to realize this fact is to study the factors affecting labor productivity.

A lot of studies have been carried out on the factors affecting employee productivity in Iran and around the world by using different techniques. The purpose of all these studies is to achieve the appropriate and certain preferences of each organization to promote employee productivity.

Tavari *et al.* (2008) in their study entitled "the identification and prioritization of the factors affecting labor productivity by using MADM techniques in one of

the jeans clothing companies in Yazd province” showed that managerial factor has the highest importance or priority and personal, cultural, social and Psychological factors are in the next places and finally environmental factor has the least importance. Alvani and Ahmadi (2001) designed a model for labor productivity. In this model, the components of leadership, motivation, experience, innovation and creativity, teaching, competitiveness spirit and demographic features were identified as the most important factors affecting productivity. Rahnavard and Khodabakhsh (2011) in their study showed that the factors affecting labor productivity are: organizational justice, organizational trust, motivation, organizational commitment, organizational support, ability, organizational citizenship behavior, personality and marital status. Also, the structural model of the relationships between the variables shows the determining role of organizational support, personal ability and organizational trust to improve productivity at the personal level. Bordbar (2013) used the TOPSIS technique to rank these factors: organizational and managerial factors, organizational support factors and service compensation system, physical, Psychological and environmental factors, degree of freedom, independency factors of employees, personal factors, the factors which create intimacy and cooperation in hospitals, planning factors and employee performance guide, the factors which strengthen the sense of commitment and loyalty in employees. Shariatmadari in their study showed that the variables of ability, clarity of role, organizational support, motivation and environment have a significant relationship with the increase of productivity. Ashuri and Fatahi in their study in Iran’s railway company showed that economic factors are the most important factors affecting labor productivity in this company and then respectively labor productivity in this company and then respectively social-psychological, cultural, personal, managerial and environmental factors are in the next places.

Connell and Hannif (2009) suggested education, training, job experiences, paying attention to technology by managers and social environment as the main factors affecting labor productivity. Jaskiewicz and Tulenکو (2012) in their study showed that four environmental factors of workload, supportive monitoring, tools and equipments, society’s support and health system affect employee productivity in order to achieve the high levels of productivity. Bahadori *et al.* (2013) in their study found that the factors of cognitive growth, organizational support, organizational culture, motivation, evaluation, ability, environment, health, training and clarity of work were the most important factors affecting labor productivity in any health care organization. Thus, it

seems that managers and officials need to pay enough attention to these variables. They should also prepare their employees with organizational support through the creation of needed rules and principles to have better productivity. Ibrahim (2013) showed that five main groups including labor, managerial factors, materials and equipments, environmental and financial factors affect labor productivity. In the study, these factors included physical, Psychological, organizational, environmental, equipment and facilities factors and also external factors included political problems. Raj and Kothai (2014) in a study aimed at identifying the factors which affect labor productivity in the municipality of Shiraz, performed exploratory factor analysis and concluded that 3 factors of (leadership and management style, personal factors and logic system of reward and punishment) were more important than the other factors affecting the increase of productivity. Karimi *et al.* (2014) in their study in Iran’s Airline Company introduced the above six factors: the abilities of employees, motivation, leadership style, environment, culture and organizational support that had a positive and significant effect on labor productivity in this company.

Movahed in a study entitled “The Measurement of Human Resources and the Identification of the Factors Affecting its Increase in Social Security General Office in Mazandaran Province” found that there is a positive relationship between the level of motivation, participatory management, training, personal features, empowerment and labor productivity.

Poirier *et al.* (2015) in their study about the measurement of the effect of modeling on labor productivity introduced the growth of labor in organizations and labor productivity as one of the main and extensive benefits of productivity management. Their findings showed that modeling the information had a positive effect on labor productivity.

Thus, in order to improve employee productivity in any organization, first its effective factors must be identified and appropriate contexts must be provided by determining these factors and the significance of each one in the improvement process of labor productivity and calculating labor productivity particularly. So that, productivity can be promoted by adjusting and performing some inform plans. Therefore, since no study has been specifically done on employee productivity, the present study attempted to provide the conceptual model of the factors affecting employee productivity in sport federation through the quantitative calculation of labor productivity and the study of the effectiveness of each factor on that conceptual model.

Research hypotheses:

- Employee productivity in Iran’s sport federations has an optimal and favorable level
- Managerial factors can predict employee productivity
- Economic and environmental factors can predict employee productivity
- Organizational factors can predict employee productivity
- Psychological factors can predict employee productivity
- Cultural and social factors can predict employee productivity
- Personal factors can predict employee productivity
- The presented conceptual model has a good fitting

MATERIALS AND METHODS

The present study is descriptive analytical that was carried out as field. In the first step (identification of indices), the research population included all experts and scholars of sport management in sport federations and universities, so 15 subjects were selected by targeted sampling method. In the second step, the statistical population included all employees working in Iran’s sport federations (n = 1394). According to Morgan’s table, 302 subjects were selected as samples by stratified random sampling method. The content validity and construct validity of the research instrument were respectively confirmed by Expert Panel method and exploratory confirmatory factor analysis. Among 310 distributed questionnaires, 250 questionnaires that were completely filled were analyzed. In the present study, according to its objectives and nature, the standard questionnaire of the factors affecting truthful employee productivity and the poll form were used to obtain the effectiveness weight of each person on federations’ productivity. For this purpose, the employees were asked to score the role of each colleague in the increase of labor productivity from 1-100 according to the developed form. The mean (average) of the opinions collected from each employee was considered as his effectiveness on federations’ productivity.

The validity of the questionnaire was confirmed by a group of experts and confirmatory factor analysis. Table 1 shows the output criteria of Amos software to confirm the measurement tool of the factors which affect employee productivity in sport federations. Goodness of fit tests of the confirmatory factor analysis mode was calculated as follows: the presence of minimum (non-significant) Chi-square (CMIN) equal to 3739/293 and significance level (p=0/000) shows a favorable and optimal result but the Degree of Freedom

Table 1: General fit indices

Index/Persian equivalent of the index	Models		
	Default	Saturated	Independence
NPAR	174	1484	53
Free parameters for the developed tool			
CMIN/DFP	3739/293	0/000	13679/190
Minimum (non-significant)	1310	0	1431
χ^2	0/000		0/000
Degree of freedom			
Significance level			
CMIN/DF	2/854		0/559
The remaining of the ratio of chi-square to degree of freedom			
RMSEA			
Root mean square error of approximation	0/086		0/185

(DF) is also important. If the degree of freedom is far from the degree of freedom of a saturated model and gets closer to the degree of freedom of an independence model, the model should be considered more favorable and optimal.

The ratio of Chi-square to Degree of Freedom (CMIN/DF) was developed to judge the instruments and supporting it by data is a more appropriate index. For this index, the values 1-5 are appropriate and the values close to 2-3 are interpreted very well. In this table, the value of relative Chi-square is 2/854 that has an acceptable status for the developed instrument.

The index of Root Mean Square Error of Approximation (RMSEA) shows if the developed instruments can be accepted or not. This index that is considered as one of the badness of fit indices, changes from 0-1 and if its obtained value is smaller, the developed model can be considered as more acceptable. It is <0/05 for the models with good fitting. Higher values to 0/08 show a logical error of approximation in the population. The models with RMSE 0/1 or more have a fitting, the value 0/086 shows that the developed instrument is acceptable. According to the presented values, the goodness of fit is at a very good level that shows a valid developed instrument to measure the factors affecting labor productivity in sport federations. To calculate labor productivity, the study results of Parhiz (2014) that was performed at the time of data collection of the present study, were used and the productivity scores of all federations were adopted from them. He had calculated productivity in sport federations by using Data Envelopment Analysis (DEA) according to the calculation of the malmquist index (Table 2). By having the number of employees in each federation, the productivity score of each employee was determined according to the following equation.

Table 2: The score of total productivity in sport federations with the malmquist index

Federation's codes	Total productivity
A	0/424
B	1/491
C	0/552
D	1/827
E	1/085
F	0/685
G	1/281
H	1/007
I	0/689
J	1/456
K	0/822
M	1/200
N	0/599
O	1/746
P	3/693
S	0/463
L	0/616
Q	0/038
R	2/337

$$(P_L) = (P_T \div T_w) \times P_w \quad (1)$$

Where:

P_L = Employee productivity

P_T = Total productivity of each federation

T_w = Number of employees in that federation

P_w = The weight of each employee's effect on the federation's productivity

RESULTS AND DISCUSSION

Research findings: The results showed that among the proposed items, the item “a proportion between personal interests and job” has the highest score in federations and the item “the presence of a feedback system” has the least score (Table 3).

In the present study, first employee productivity in each federation was calculated according to Eq. 1 in order to study the effect of each factor on labor productivity. For example, the findings of total productivity in federations by the malmquist index showed that the total productivity of federation A is 0/42. According to the opinion of employees, the effectiveness rate of employees on different positions in federation A was identified. After putting the obtained numbers in Eq. 1, the score of employee productivity in federation A was obtained (Table 4).

Accordingly, the mean score of employee productivity in all studied federations was calculated. (Table 5). The results of Table 5 show that the employees of federation R had the highest productivity and the employees of federation Q had the least productivity. To determine the effectiveness rate of each determined factor on employee productivity, the structural equations were used.

Table 3: The mean items of the questionnaire of the factors affecting labor productivity from the perspective of employees in the studied federations

Aspects items	Mean
Personal factors	
The fit between field of study and job	3/70
The fit between personal interests and job	4/10
The fit between personal skills and job	4/06
Social and cultural factors	
Having employees with high work ethic the spirit of teamwork among employees	3/61
The availability of the field of creativity and innovation in federation	3/48
The positive attitude to the development and improvement of employees	3/25
Loyalty of employees to rules and regulations	3/57
The sense of responsibility in the relevant job	3/80
Spirit of loyalty and commitment to the organization	3/80
Using the Federation's active website	3/85
Psychological factors	
A sense of fairness in working conditions in Federation	3/56
The intimate relationship between employees	3/19
The feeling of having job security among employees	3/62
Satisfaction with the relevant job	3/21
Feeling good relationships between managers and employees	3/51
The sense of belonging to the organization	3/77
The rate of having a psychological secure environment in the workplace	3/68
The activities carried out in order to enhance creativity and innovation	3/46
Organizational factors	
The presence of a feedback system in federation	3/04
The specific organizational hierarchy in federation	3/85
The rational division of tasks based on expertise	3/39
The enforcement of laws and regulations and detailed instructions by employees	3/22
The presence of standards and criteria for tasks in federation	3/46
The amount of duties and job descriptions for each task or activity	3/52
Having a database in federation	3/33
The access to the information needed for planning and decision-making	3/39
The fit between needed labor and work	3/47
Using transformational leadership style by managers in federation	3/33
Using participatory leadership style by managers in federation	3/19
Managerial factors	
Timely promotion of employees according to their competence	3/36
The continuous monitoring and control activities of manager	3/78
The participation of workers in decision-makings by manager	3/30
Coordination and cooperation between different units and groups by manager	3/55
Holding meetings with managers and employees on issues and problems of employees	3/34
Dealing with complaints and protests by manager	3/50
The implementation of reward and punishment system	3/16
Employee involvement in organizational goals	3/25
The delegation of authority employees by manager	3/40
Moral and material support of creative and innovative employees	3/21
Job rotation in Federation	3/06
In-service training in the Federation	2/90
Economic and environmental factors	
The appropriateness of the level of salary and cash bonus payments with employee performance	3/01
The appropriateness of the remuneration of non-cash and (transportation, non-cash benefits medical costs, etc.) with employee performance token	2/96
The appropriateness of fair allocation to different units according to their workload and activity	3/13
Having facilities and amenities in organization	2/90
Having adequate equipment to carry out the desired amount of work	3/10
Having the needed equipment for information and communications technology	3/30

Table 3: Continue

Aspects items	Mean
The potential of organization in holding training courses to increase the level of knowledge and expertise	3/35
Having good design and appearance of work environment (cleanliness, freshness and coloring, etc.)	3/11
Observing the safety and health at work environment	3/33
Having the Maintenance System at work environment	3/29
Having a standard office space for doing works	3/22

Table 4: The score of employee productivity in federation A

Organizational position	The weight of the person's impact on federation's productivity	Score of employees productivity	The mean score of employee productivity in federation A
Chief	60/86	1/21	1/06
Vice chairman	70/51	1/41	The fifteenth
Secretary	61/10	1/22	
Head of public relations	22/06	0/44	
Head of international relations	22/06	0/44	
Head of secretariat	76/55	1/53	
Consultant	89/13	1/78	
Supplier	62/44	1/24	
Employee	17/5	0/35	

Table 5: The mean score of employee productivity in federations

Ranks	The mean score of employee productivity	Federation code
1	11/22	R
2	4/26	I
3	4/04	J
4	3/73	M
5	3/48	H
6	3/18	L
7	3/01	E
8	2/88	F
9	2/61	K
10	2/52	B
11	2/41	C
12	1/89	N
13	1/77	G
14	1/64	O
15	1/06	A
16	0/11	Q

According to Table 6, economic, environmental, managerial, organizational and Psychological factors affect labor productivity but personal, cultural and social factors have no role in labor productivity in sport federations. The results of Table 7 show that the above model has a good fit. Psychological factors had the highest role and personal factors had the least role in employee productivity in federations (Fig. 1).

All thinkers and scholars of physical education and sport have mentioned some aspects of employee productivity process but not a comprehensive model of the aspects and indices of employee productivity and the relationship between them has been provided yet. Achieving an appropriate mode of labor productivity according to the nature of each sport federation needs

identification and prioritization of factors in terms of importance according to criteria and valid scientific methods. Identification and classification of the factors affecting employee productivity according to accurate and scientific methods in sport federations is one of the important federations are productivity, they can use other sources in a good and optimal way and realize all kinds of productivity and finally make their federations productive, otherwise recession and backwardness will bring passive and non-motivated human resources. The present study was performed with the aim of providing the conceptual model of the factors affecting employee productivity in sport federations.

The results showed that among the items proposed in interpersonal part, the item “a proportion between personal interests and job” has the highest score in federations. Since the proportion of personal interest and job can finally lead to the increase of effectiveness in activities, federations’ managers should pay enough attention to the interest of employees and provide the necessary conditions to increase this proportion and achieve organizational goals faster. The results showed that in the part of cultural and social factors, the rate of having loyalty spirit and commitment to organization has the highest importance in the promotion of employee productivity. Bordbar in ranking the factors affecting labor productivity found that organizational commitment and strengthening the sense of loyalty and commitment in employees are of great importance as mentioned in the present study. Data analysis showed that among meaningful factors affecting labor productivity, “the continuous monitoring and control of activities by managers” had the highest importance in the promotion of employee productivity. In this regard, Shariatmadari stated that the variable “evaluation” is not one of the factors affecting employee productivity in the school of dentistry at Tehran University of medical sciences. This result is not consistent with the findings of the conducted study in sport federations. The root of this difference can be attributed to the appropriate and applied systems of sport federations.

Jaskiewicz and Tulenko (2012) in their study mentioned the importance of monitoring and its effect on employee productivity that according to the results of the present study which emphasize this issue and monitoring activities by managers as the first rank of effectiveness on employee productivity, some measures should be taken to improve this problem. Among the items considered in organizational factors, the results showed that “the determined area of tasks and description of job for each task” had the highest importance in the promotion of

Table 6: The path coefficients of the factors affecting labor productivity in sport federations

Parameters	The factors affecting labor productivity	Critical value CR	The standard error of estimate SE	The amount of non-standard load factor	p-value
Score of employee productivity	Economic and environmental factors	0/266	0/688	0/250	0/010
Employee productivity	Managerial factors	0/268	0/591	0/215	0/027
Employee productivity	Organizational factors	0/255	0/537	0/203	0/035
Employee productivity	Social and cultural factors	0/511	0/454	0/089	0/374
Employee productivity	Personal factors	0/255	0/039	0/015	0/877
Employee productivity	Psychological factors	0/232	0/645	0/267	0/006

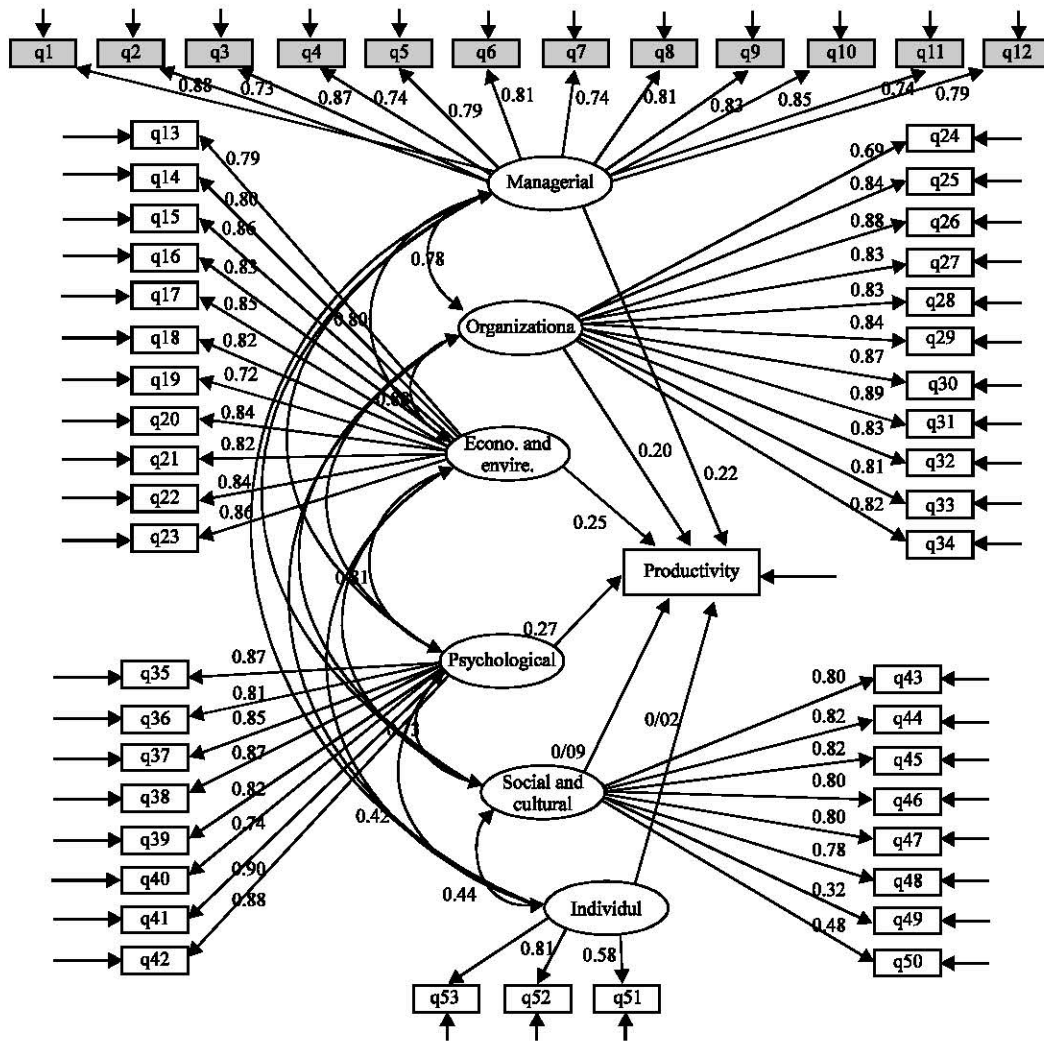

Fig. 1: The structural model of the factors affecting labor productivity

employee productivity. Shariatmadari also referred to the importance of clarity of role and task description as a factor that can have a significant effect on employee productivity. Data analysis showed that among the economic and environmental factors affecting labor productivity, the rate of organizational empowerment in holding training courses to increase the level of knowledge and expertise had the highest importance in the promotion of employee productivity.

Also, among the items considered in Psychological factors, establishing good relationships between manager and employee had the highest importance in the promotion of employee productivity. In their study found that considering the essential needs of employees, participation of employees in decision-makings and participatory leadership style of manager can increase employee productivity. This issue was of particular importance in the results of this study and had the highest score.

Table 7: Goodness of fit indices (the factors affecting labor productivity)

Index names	The calculated value for the model	Appropriate value for a good fit
Relative Chi-square index (CMIN/DF)	2/821	Between 1-5
Parsimonious Comparative Fit Index (PCFI)	0/590	Values bigger than 0/5 or 0/6
Root Mean Square Error of Approximation (RMSEA)	0/049	Values close to 0/05

In line with the mean score of employee productivity in 16 selected federations in the present study, federation R with mean score 11/22 was placed in the first rank and federation Q with 0/11 was placed in the last rank. Different reasons may identify the issue that federation Q had the least employee productivity among other federations. But the lack of paying attention to the needs of employees and their low participation in decision-makings, lack of paying attention to the proportion between personal interests and their job (Aqayi, 2011), non-determined tasks and low control and monitoring by manager and each issues that were emphasized in the present study, can be the probable reasons of low employee productivity in this federation. Also, the probable reasons of high scores of employee productivity in federation R can be the leadership style of this federation where teamwork, participation and implementation of reward and punishments system (Bordbar, 2013) and so on.

One of the very important cases that was investigated in this study and no study has ever mentioned it is the calculation of productivity score if each organizational position in sport federations. As was mentioned, the score of productivity was calculated for each sport federation and according to it, the mean score of employee productivity in all federations participated in the present study was stated (Table 5).

Sufi and Shabani (2013) introduced some factors like human resources, managerial factors, materials and facilities, environmental and financial factors as the factors affecting labor productivity that are consistent with the present study in terms of paying attention to labor, managerial and environmental factors. Bahadori *et al.* (2013) also introduced some factors like organizational support, organizational culture, motivation, evaluation, ability, environmental, health, training and clarity of work as the factors affecting labor productivity. These cases were included somehow in each one of the factors of the present study, so that organizational support and evaluation are in the category of managerial factors, motivation is in the category of Psychological factors, ability is in the category of personal factors, health is in the category of environmental factors and clarity of work is in the

category of organizational factors. Abdi *et al.* (2011) also performed exploratory factor analysis and introduced 3 factors (management style, personal factors and reward and punishment system) more important than other effective factors in labor productivity. These factors were examined in the present study, so that Psychological factors with the highest load factor were placed in the first rank and personal factors were placed in the last rank. Karimi *et al.* (2014) introduced the factors affecting labor productivity as follows: ability of employees, motivation, environment, culture, leadership style and organizational support.

It should be noted that these factors in the present study were introduced in the form of personal, Psychological, environmental and cultural factors. Also, the style of leadership called participatory and transformational leadership and organizational support included in meaningful factors were investigated in the present study. The study results of Sufi and Shabani (2013) showed that federation employees have enough job satisfaction that can improve their productivity and this fact is in line with the findings obtained in this study. The fitted model for labor productivity in Iran's sport federations has 6 components and their degree of importance and the relationship between them were specified. Among the mentioned groups, Psychological factors have the highest effect on employee productivity in Iran's sport federations. This result is consistent with the findings obtained from the study of Heather (2002) while in the study of Ashuri and Fatahi, economic factors were the most important factors and environmental factors were the least important ones, in the study of Aqayi, economic factors were in the first rank and demographic factors were in the last rank. It was also observed that in the study of Bordbar, organizational and managerial factors that were identified as the most important factors. The observed differences in results are probably related to the population of organizational environment that is sport federation.

CONCLUSION

According to the designed model and based on its appropriate fitting, the effective factors of employee productivity in sport federations can be used to study employee productivity. So that, the weakness of each discussed factor can decrease employee productivity. Thus, it is necessary to study these factors and strengthen their weakness to promote employee productivity. Using the results of this study can improve the development process of effectiveness and efficiency of employee activities. For this purpose, the country's federations as the executives of championships should have capable labor and human resources in order to realize this issue.

ACKNOWLEDGEMENTS

We would like to thank the Minister of Youth and Sports Ministry and the sincere cooperation of friendly and sympathetic employees in the federations participated in this study (Federations of bodybuilding, judo, skiing, archery, lifeguarding, veterans and the disabled, cycling, handball, squash, skating, wushu, swimming, boxing, martial arts and general sports) whose names were presented in the form of code due to observing reproach ethics.

REFERENCES

- Abdi, H., R.R. Nejad, B. Yousefi, N. Sajadi and M.I. Khalagh, 2011. The design of an organizational effectiveness model for Iran's sports federations based on competing value approach. *J. Sport Manage. Motor Behav.*, 14: 15-30.
- Alvani, M. and P. Ahmadi, 2001. The design of a comprehensive management pattern for the affecting labor productivity. *J. Mange.*, 5: 1-19.
- Aqayi, N., 2011. The effect of demographic, economic and social factors on labor productivity in the education system of Tehran. *J. Sport Manage. Motor Behav.*, 14: 113-130.
- Bahadori, M., E. Teimourzadeh and M.H. Farahani, 2013. Factors affecting human resources productivity in a military health organization. *Iranian J. Military Med.*, 15: 77-86.
- Bordbar, G., 2013. Factors affecting labor productivity by using multiple criteria decision making techniques, case study: The employees of Shahid Sadoughi Hospital. *Yazd Health Manage.*, 16: 70-83.
- Connell, J. and Z. Hannif, 2009. Call centres, quality of work life and HRM practices. *Employee Relations*, 31: 363-381.
- Heather, K.S., 2002. The impact of workplace empowerment, organizational trust on staff nurses work satisfaction and organizational commitment. *Adv. Health Manage.*, 21: 56-85.
- Ibrahim, M., 2013. Principal factors impacting labor productivity of public construction projects in Palestine: Contractors perspective. *Intl. J. Archit. Eng. Constr.*, 2: 194-202.
- Jaskiewicz, W. and K. Tulenko, 2012. Increasing community health worker productivity and effectiveness: A review of the influence of the work environment. *Hum. Resour. Health*, 10: 1-9.
- Jones, D.C., P. Kalmi and A. Kauhanen, 2006. Human resource management policies and productivity: New evidence from an econometric case study. *Oxford Rev. Econ. Policy*, 22: 526-538.
- Karimi, M., Y. Chaghoeue and M. Hamidpour, 2014. Determination of effective factors on human resources productivity case study: Iranian Air port Company. *Appl. Math. Eng. Manage. Technol.*, 2: 117-123.
- Mohammadi, R., H. Honari and S. Keshgar, 2014. Examining the relationship between the sub-systems of knowledge management in learning organization and labor productivity in selected sports federations. *Sports Manage.*, 6: 57-74.
- Parhiz, R., 2014. Measuring productivity in Iranian sports federation. Master Thesis, University of Birjand, Birjand, Iran.
- Poirier, E.A., S.S. French and D. Forgues, 2015. Measuring the impact of BIM on labor productivity in a small specialty contracting enterprise through action-research. *Automation Constr.*, 58: 74-84.
- Rahnavard, F. and M. Khodabaksh, 2011. The structural model of improving manufacturing employees. *Public Manage.*, 3: 81-94.
- Raj, B.V.A. and P.S. Kothai, 2014. Improving the labour productivity through other resources in construction field. *Intl. J. Eng. Res. General Sci.*, 2: 205-213.
- Sufi, M.R. and A. Shabani, 2013. The relationship between the motivating job factors based on Herzberg's model and job satisfaction of employees in sports federations. *Appl. Res. Sport Manage.*, 2: 33-42.
- Tavari, M., M.A. Sokhkian and A. Mirnejad, 2008. Identification and prioritization of the factors affecting labor productivity by using MADM techniques (Case Study: One of the jeans clothing companies in Yazd Province). *J. Ind. Manage.*, 1: 71-88.