



Journal of Applied Sciences

ISSN 1812-5654

science
alert

ANSI*net*
an open access publisher
<http://ansinet.com>

Path of Synergistic Effect of Chinese University Spin-offs Based on SEM-AMOS Method

¹Hao Zhang, ¹Yunlong Ding and ²Lan Du

¹School of Management,

²Science and Industrial Technology Research Institute,
Harbin Institute of Technology, Harbin, China

Abstract: This study utilizes the China University Spin-offs Survey data to identify the influence process from institutional innovation and organizational learning to synergistic effect of organization. First, we found that following the procedural view, each one of these three elements can be divided into two parts. Then, we established structural equation modeling with the connections between these six subdivisions. Sec, by taking 270 university Spin-offs in China as samples, we verified the fit of the model through statistical data on the questionnaire survey. After that, we analyzed the relationship and influence path of the institutional innovation, organizational learning and synergistic effect. The results of empirical research show that institutional implementation process is positive correlation on both sides of synergistic effect and the intermediary role is obvious that external organizational learning played a regulatory role between institutional innovation synergistic effects.

Key words: Institutional innovation, organizational learning, synergistic effect, university spin-offs, SEM

INTRODUCTION

The core of strategy “Innovation drives development” is to solve the problem of how to drive is also how to make industrialization and commercialization of scientific and technological achievements. As the academician of China Academy of Engineering, it is important to create new mechanism by which to integrate the technology innovation achievements effectively and apply it to practice (Xue and Ma, 2013). The cooperation of university, industry and research institute in China now is developing to the “five in one mode” which also contained government and market application-oriented which gives full play to multi-subjects advantage of government, universities and research institutes and it is defined as a typical kind of synergy innovation (Jia and Zhang, 2013). Synergy innovation is an innovational behavior which follows the goals of innovation, more subjects were involved and multiple factors were assisted, complemented and cooperated each other (Li, 2011). Thus, the main issue of this study is how to implement institution innovation which promoted synergistic effect in the organization operation. University spin-offs are various forms of enterprises which relied on scientific research achievements of universities and were set up in forms of wholly owned, controlled or participation by university (Hao, 2005). In China, with the

development of universities and the increased demand of innovation, the development of university spin-offs is rapid and it becomes an important part of national innovation system. University spin-offs are the product of university-industry collaborative innovation. Compared with the traditional innovation main subject, University spin-offs are different in property and organization form. As the former one, it is different from public welfare institutions, while as the latter one, it is also not completely the same as other enterprises. University spin-offs were registered as separate legal person, so, it is different from the traditional secondary units of universities. The relationship between university and spin-offs is gradually changing from original directly management to a shareholding structure.

The empirical research method is used in this study. The authors selected 270 China university spin-offs as samples. By the investigation and questionnaire, a structural equation model was made for the influence factors of the effect of synergy innovation. Then, we discussed the correlation between the institutional innovation, organization study and synergies effect through the model test. On the basis of the discussions, we analyzed the path and mechanism of the synergies effect and put forward the countermeasures and Suggestions for the development of Chinese university spin-offs.

THEORETICAL FRAMEWORK AND HYPOTHESES

Institutional innovation and synergistic effect: In the macro level, the synergistic effect of institution is reflected in the relationship between the technology and institution, such as the representative of evolution economics, believes that co-evolution of institution and technology is regarded as the main driving force behind economic growth, technology innovation, institution innovation and industry system evolution showed a trend of spiral co-evolution; it must keep the synergistic effect of technology innovation and institution innovation that the enterprises achieved sustained development, only the synergy degree of technical innovation and institutional innovation is high, can enterprise be in sustained growth (Xu and Xu, 2008); if there is only technology innovation, It will appear closure effect; and if only institution innovation, it will become the bricks without straw (Li and Ma, 2001).

From the perspective of internal and external conditions of the development of university spin-offs, the enterprise institution innovation included external institutional environment construction and internal management innovation. On the one hand, support from universities and the government are major drivers of the sustainable development of the enterprise (Jia and Jia, 2012) which provides a good innovational environment for the organization's development; on the other hand, university spin-offs should constantly adapt to the market environment, adjust the relationship with universities, government and other organizations, improve the modern enterprise system and conduct management innovation. As a result, this study puts forward the following hypothesis:

H1a: Institutional environment is positively related to transverse synergy effect

H1b: Institutional implementation is positively related to transverse synergy effect

H2a: Institutional environment is positively related to longitudinal synergy effect

H2b: Institutional implementation is positively related to longitudinal synergy effect

Organizational learning and synergistic effect:

Organizational learning has a positive influence on innovation performance innovation happened in the process of organizational learning and it requires members to search for the existing knowledge actively and shared these knowledge within the organization, when the new common understanding on these shared knowledge is created, the innovation is coming (Schein, 1985). The empirical research shows that organizational learning has significant positive correlation both on organizational and

individual level of innovation performance but the role of the latter is stronger than the former (Wang and Ellinger, 2011). Wang and Fang verified that organizational learning has a significant positive influence on enterprise technology innovation performance and put forward that organization learning played the part of the intermediary role in the path of organizational culture acted on the technological innovation performance (Wang and Fang, 2013). Xie had study on the relationship among social capital, organizational learning and organization innovation and found that the organizational learning has a positive influence on the management innovation and technological innovation (Xie *et al.*, 2008) and in the further empirical studies, he found that innovation is the intermediary variables of organization learning and organization performance and the influence that organizational learning takes impact on the innovation management is greater than on technology innovation (Xie and Han, 2005).

The influence of organizational learning acted on organizational operation ability and the dynamic capabilities are different from each type of organizational learning, thus, these two kinds of ability can affect organization mode of technology innovation by sharing, applying and creating knowledge inside the organization (Zhou and Li, 2005). Chen and Wang found that both the exploratory study or use of the learning have a positive influence on organizational performance; Environmental dynamics had a negative regulating effect between exploratory study or use of the learning on organizational performance (Chen and Wang, 2012). There is a close relation between organization learning and innovation. Organization culture also had a close relation with the enterprise innovation performance. At the same time, it has reached a consensus that there is a close relation between organizational culture and innovation performance, a growing body of research emphasized that the organization culture is the key to the management innovation (Wang and Fang, 2013).

In a conclusion, the content, mode and structure of organization learning have strong connection with the formation path, mechanism and main influencing factors of the synergistic effect; as a result, this study puts forward the following hypothesis:

H3a: Internal organizational learning is positively related to transverse synergy effect

H3b: External organizational learning is positively related to transverse synergy effect

H4a: Internal organizational learning is positively related to longitudinal synergy effect

H4b: External organizational learning is positively related to longitudinal synergy effect

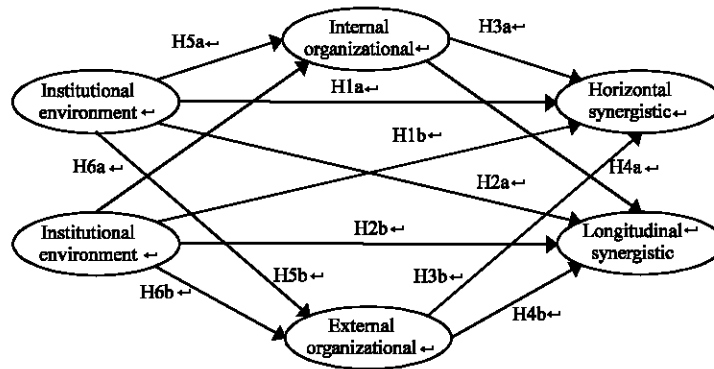

Fig. 1: Research framework

Institution innovation and organizational learning: The Institutional change theory argued that the behaviors pursued benefit maximization will expand the market size, promoted further development of specialization and division of labor and resulted the changes of relative commodity price of production factors and information. Therefore, people put forward the requirement of the new institution, so as to show the drivers of institution innovation. If the organizational members want to get the maximum benefit, they need to master certain knowledge and skills which are from learning by doing within the framework of institution. That is to say, in the process of the replacement of the old institution and the implementation of the new institution, the organization will solidify the institution into the organizational behavior constraints by learning. on the other hand, there is path dependence in the process of institutional change, because some institutional inertia is in the process of institution innovation which makes it be in the original path that the development and alternative of institution. Thus, the learning processes which unique organizational development trajectory will be strengthen by it. JIA pointed that the institutional environment has a positive influence on absorptive capacity, knowledge transfer and resource integration of enterprises (Jia and Jia, 2012), above all is the manifestation of organization learning ability. Therefore, the institution innovation is a preposition factors of organizational learning, the organization performance under the perspective of institutional change should go through learning and adaptation process.

Therefore, from the purpose point of view, both the institution innovation and organizational learning have the same goal; from the dynamic point of view, the motivation of institution innovation is group earnings maximization and the one motivation of organizational learning is the strengthen innovation ability (Fig. 1). As a

result, this study puts forward the following hypothesis:

- H5a:** Institutional environment is positively related to internal organizational learning
- H5b:** Institutional environment is positively related to external organizational learning
- H6a:** Institutional implementation is positively related to internal organizational learning
- H6b:** Institutional implementation is positively related to external organizational learn

DATA, VARIABLES AND METHODOLOGIES

Questionnaire design and measuring tool: This study used the questionnaire for data collection. In the questionnaire, in addition to the basic questions about the object were tested, the others questions were asked to filled in the seven point Likert scale. To ensure that the content of the questionnaire were correctly reflected the characteristics of latent variables, the authors first refer to the scale of domestic related research and conclusion. On this basis, through the investigations and meetings, the authors respectively discussed with the related government department managers, head managers who charged in spin-offs in the university, manager of spin-offs and the scholars, after that, we created the initial questionnaire and a small-scale is pre-tested. Then, aiming at revising the problems reflected from pre-test, we re-designed or eliminated the inaccurate problems. Finally, the questionnaire can be taken in use.

The measurement of institution innovation is mainly carried out in two aspects: Institutional environment and institutional implementation. First of all, the institution innovation process began at institution design which is conducted by organization according to the strategic target. Institutional environment is an external factor of institution innovation; institutional innovation must be in

Table 1: Profiles of sample enterprises

Years of enterprise	Quantity	Percent (%)	No. of employees	Quantity	Percent (%)	Annual sales	Quantity	Percent (%)
Below 2	15	6.91	Below 50	88	40.55	Below 100	28	2.90
2-4	32	14.75	50-100	45	20.74	100-500	32	14.75
4-8	37	17.05	100-300	47	21.66	500-1000	21	9.68
Above 8	133	61.29	Above 300	37	17.05	1000-5000	68	31.33
						Above 5000	68	31.33

process of implementation smoothly within the condition of good institutional environment. Meanwhile, implementation of new institution is a process of institution curing in organization, also is a process of management innovation. The items which measure institution design are organizational governance structure and management level; the items which measure institutional environment dimension focused on how the universities and government to promote and support the development of the enterprise; the items which measure behavior dimension of institutional innovation focused on the enterprise changed or redesign the institution rules and procedures to stipulate the behavior of employees.

The measurement of organizational learning is mainly carried out in two aspects: In the one hand, the institution curing process in organization needs to break the original organizational routine, on the other hand, it needs to adapt to the new behavior patterns which are formed by a new institution. Therefore, the measurement of organizational learning included organizational behavior, organizational routines and organizational stability, etc., which are internal and external learning in form.

The synergy innovation is different from single organization performance and emphasized population effect and pay more attention to the organization between total synergistic characteristic among different organizations. As a result, according to classification of synergy innovation of the above studys, there are to kind: Transverse synergy innovation and longitudinal synergy innovation. The items which measure transverse synergy innovation focused on the synergy effect of innovation subjects, such as universities, enterprises and research institutions, focusing on the collaborative process of technology innovation. The items which measure longitudinal synergy innovation focused on the synergy effect on the supply chain, it is the process of "production" and "consumption" of technology with market value-oriented.

Research sample and data collection: Research samples are from 80 spin-offs, in which 50 universities subordinate to the ministry of education and 30 universities are provincial, we provided 301 questionnaires and recycled 270. With some of them rejected, 217 samples are valid. Among the investigation object, there are 33 enterprises

which is the universities wholly-owned, accounting for 15.21%; 53 enterprises are University holding, accounting for 24.42%; 88 enterprises are colleges and universities participated in, accounting for 40.55%; Other 43, accounting for 19.82%. Look from the industrial distribution, electronic information and technology are 84 accounting for 34.85%; Biotechnology and new medicine are 19, accounting for 7.88%; New materials and application technology are 17, accounting for 7.05%; advanced manufacturing technology are 30, accounting for 12.82%; aeronautics and astronautics are 5, accounting for 2.07%; Modern agricultural technologies are 7, accounting for 2.90%; New energy and high efficiency and energy saving technology are 17, accounting for 7.05%; environmental protection technology are 15, accounting for 4.98%; Others are 51, accounting for 21.16%, the samples are good, representative (Table 1).

STATISTICAL RESULTS

In this study, the author use the structural equation model as the research method, then, the data processing is mainly completed under the environment of AMOS7.0, finally, the maximum likelihood method is used for model fitting.

Measurement model: We analyzed the measurement model of integration model, calculated average variance extracted (AVE) of latent variables and composite reliability according to the standardized factor loading, the result detailed in Table 2.

According to Table 2, the value of factor loading which manifest variables as for each latent variables is after the standardization, is between 0.53 and 0.94 (more than the threshold value of 0.5). The calculation of AVE is between 0.500-0.714 (more than the threshold value of 0.5) which shows convergent validity of latent variables is ideal and has the good operational definition. According to Table 2, the value of composite reliability which is calculated by factor loading after the standardization of manifest variables corresponding for the latent variables, is between 0.798-0.798 (more than the threshold value of 0.7). It reveals that the stability of measurement model is very ideal.

Table 2: Results of measurement model

Latent variable	Measurement index	Factor loading	AVE	CR
Institutional implementation (II)	II1: The enterprise has a clear division of responsibility and workload	0.66	0.562	0.858
	II2: The salary of R&D department is related to contribution	0.57		
	II3: The operations of the enterprise to keep low-cost		0.53	
Institutional environment (IE)	II4: The governance structure of the enterprise is optimization	0.94	0.500	0.798
	II5: The enterprise management level is continuously improved	0.72		
	IE1: The universities provided a good business environment for enterprise	0.61		
	IE2: The enterprise obtained the governmental tax preference	0.82		
Internal organizational learning (IL)	IE3: The enterprise obtained the governmental technology innovation fund or the funding for research and development	0.57	0.578	0.890
	IE4: The enterprise obtained the land resources, etc from government with a preferential price	0.85		
	IL1: The information, experience and skills can be shared among the employees	0.84		
	IL2: The Information and working procedure is not affected by personnel changes	0.77		
		0.66		
		0.91		
External organizational learning (EL)	IL3: Multiple departments together to develop new products	0.90	0.646	
	IL4: The employees can easily access to information	0.71		
	IL5: The employees can apply effective information to work in time	0.61		
		0.83		
		0.84		
Transverse synergy effect (TS)	IL6: Organization (information system) can deliver important information in a time	0.76	0.717	0.897
	EL1: The enterprise often conduct the technical communication with external research institutions	0.88		
	EL2: The enterprise have good experience of cooperation with external research institutions	0.81		
	EL3: The enterprise focus on external technology development trend	0.84		
Longitudinal synergy effect (LS)	TS1: universities provided enterprises with technology innovation support	0.67	0.885	
	TS2: The company salesman will share the information of competitors			
	TS3: The enterprise will response to competitors' actions quickly			
	TS4: Corporate executives often discuss the advantages and disadvantages of the competitors			
	LS1: The enterprise has a closely relationship the trust with partners in the supply chain			
	LS2: The enterprise has a consistent interests with partners in the supply chain			
	The enterprise try to support each other with partners in the supply chain			
	LS4: The enterprise has a good cooperation with advertising and other intermediary organizations			

Table 3: Descriptive statistics and discriminate validity analysis of latent variables

Variables	Mean	SD	II	IE	IL	EL	TS	LS
II	5.720	0.525	0.500					
IE	4.572	0.642	0.086	0.562				
IL	5.681	0.232	0.025	0.475	0.578			
EL	5.685	0.179	0.103	0.250	0.201	0.714		
TS	5.557	0.202	0.093	0.388	0.574	0.370	0.646	
LS	5.486	0.332	0.089	0.346	0.382	0.261	0.444	0.717

Discrimination of discriminant validity: Descriptive statistics for each latent variable are made according to the literature (Wu, 2009), the latent variables must possess a validity. In this study, the authors used method that compared the average variation extraction quantity with the square of the correlation coefficient, to distinguish the validity of the latent variables, the calculation results are shown in the Table 3.

In Table 3, it is on behalf of the AVE of latent variables that the diagonal elements which are beside of two columns data of the mean and standard deviation, the others data is on behalf of the correlation coefficient square of the latent variables. It is clear that the mean of any two latent variables AVE is greater than the

correlation coefficient square which shows the validity of latent variables is very ideal and distinguishes a good operational definition

Analysis of SEM: In this study, the authors established the structural equation model under the AMOS interface with the help of SPSS 16.0 and AMOS 17.0 software. Then, we used 217 large sample data to fit of the mode and completed the output result. The related parameters of structural equation model are shown in Table 4.

The hypothesis testing of structure model was shown in the Fig. 2. The H1a (institutional environment→transverse synergy effect), H2a (institutional environment→the longitudinal synergy effect) and H5a

Table 4: Indexes of SEM

Result	Trend	Category	Estimate	S.E.test	C.R.test	P test
Internal organizational learning	<---	Institutional environment	-0.007	0.029	-0.254	0.800
Internal organizational learning	<---	Institutional implementation	0.460	0.065	7.116	***
External organizational learning	<---	Institutional environment	0.117	0.034	3.396	***
External organizational learning	<---	Institutional implementation	0.332	0.054	6.116	***
Transverse synergy innovation	<---	Institutional environment	0.044	0.027	1.638	0.102
Transverse synergy innovation	<---	Institutional implementation	0.094	0.056	1.675	0.094
Longitudinal synergy innovation	<---	Institutional environment	0.057	0.037	1.522	0.128
Longitudinal synergy innovation	<---	Institutional implementation	0.163	0.078	2.098	0.036
Transverse synergy innovation	<---	Internal organizational learning	0.599	0.109	5.512	***
Transverse synergy innovation	<---	External organizational learning	0.350	0.074	4.737	***
Longitudinal synergy innovation	<---	Internal organizational learning	0.566	0.116	4.879	***
Longitudinal synergy innovation	<---	External organizational learning	0.323	0.090	3.592	***

Table 5: Effects analysis

Predictive variable	Internal organization learning	External organization learning	Transverse synergy innovation	Longitudinal synergy innovation
Direct effect				
Institutional environment	n.s.	0.117	n.s.	n.s.
Institutional implementation	0.460	0.332	0.486	0.531
Internal organization learning			0.599	0.566
External organization learning			0.350	0.323
Indirect effect				
Institutional environment			0.041	0.038
Institutional implementation			0.381	0.367
Total effect				
Institutional environment			0.041	0.038
institutional implementation			0.867	0.898

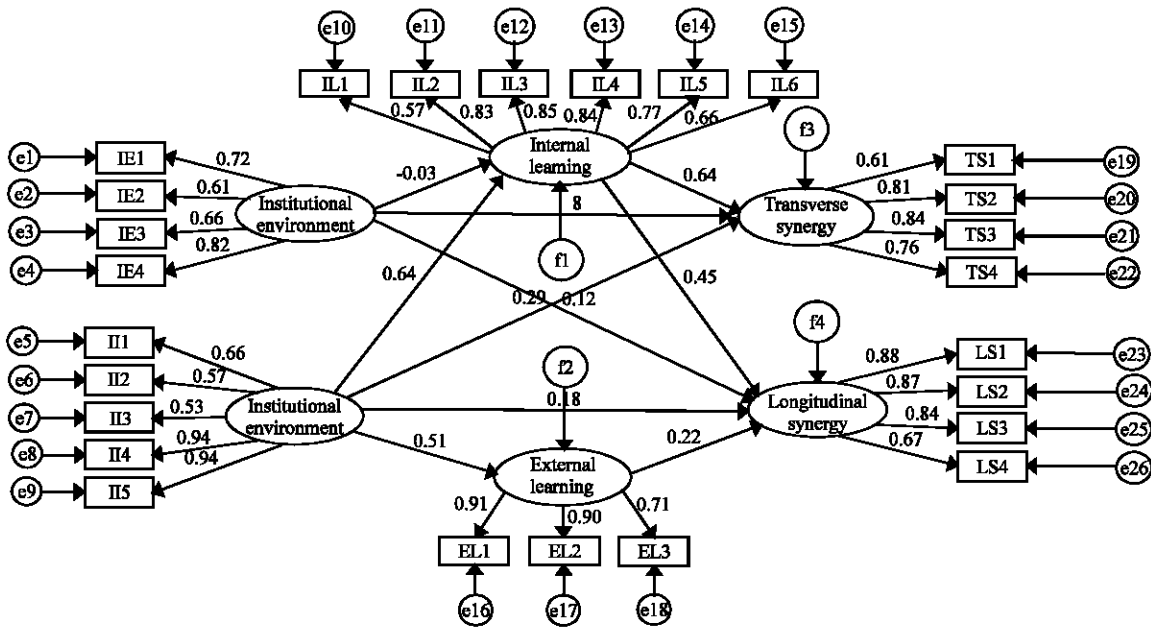

Fig. 2: Integrated mode

(institutional environment-organization learning) were failed to pass the significance test in this study, the remaining nine basic assumptions are passed the significance test.

Direct, indirect and total effect: According to Fig. 2, the authors compared and calculated the effect of variable function, the results detailed in Table 5. According to the

logic of MacKinnon, if the parameters of both relationship of independent variable to the intermediary variable and the intermediary variable to the dependent variable are not zero, the intermediary effect established apparently (MacKinnon *et al.*, 2002). Therefore, in Fig. 2 and Table 5, it reveals that the intermediary role of organizational learning, internal organization learning plays a intermediary role between institution implementation and

longitudinal synergy innovation; External organization learning plays a intermediary role between institutional environment and transverse synergy innovation and so do it between the institutional implementation and longitudinal synergy innovation.

RESULTS AND DISCUSSION

- For the internal organizational learning, the positive influence caused by institutional environment didn't pass the significance test, therefore, H5a (institutional environment→internal organization learning) was rejected; the standardization path coefficient of positive influence that caused by institutional implementation was 0.635 which passed through the significance test and verified assumption that internal organizational learning is affected positively by institutional implementation, therefore H6a was established. For the external organizational learning, the standardization path coefficient of positive influence caused by institutional environment was 0.252 and caused by institutional implementation was 0.449, both of them passed the significance test and verified assumption that external organizational learning is affected positively by institutional environment and institutional implementation, therefore, H5b, H6b were established. The standardized path coefficient 0.252 is less than 0.449, shows that as for the degree of influence to, institutional implementation is greater than institutional environment
- For the transverse synergy effect, the positive influence caused by institutional environment didn't pass the significance test, therefore, H1a (institutional environment→transverse synergy innovation) was rejected; the standardization path coefficient of positive influence that caused by institutional implementation was 0.125, the one caused by internal organizational learning was 0.575, the one caused by external organizational learning was 0.343, all the three passed through the significance test, so the H1b, H3a, H3b were established. For the longitudinal synergy effect, the positive influence caused by institutional environment didn't pass the significance test, therefore, H2a (institutional environment→longitudinal synergy innovation) was rejected; the standardization path coefficient of positive influence that caused by institutional implementation was 0.174, the one caused by internal organizational learning was 0.439, the one caused by external organizational learning was 0.256, all the three

passed through the significance test, so the H2b, H4a, H4b were established

- The analysis based on the view on total effect which institution innovation acted on synergy effect are as follow: For the transverse synergy effect, the direct effect caused by institutional environment does not exist, while the indirect effect through external organizational learning as the intermediary variable is 0.041 (0.117×0.350), so the total effect is 0.041. The direct effect caused by institution implementation is 0.486, the indirect effect through both internal and external organizational learning as the intermediary variable is 0.392, among which the intermediary effects caused by internal learning is 0.276 (0.460×0.599) and the one caused by external learning is 0.116 (0.332×0.350). Since, 0.276 is greater than 0.116, it shows that the intermediary effect of internal learning is higher. Therefore, the total effect of institutional implementation acted on transverse synergy effect is 0.878

For the longitudinal synergy effect, the direct effect caused by institutional environment does not exist, while the indirect effect through external organizational learning as the intermediary variable is 0.038 (0.117×0.323), so the total effect is 0.038; The direct effect caused by institution implementation is 0.531, the indirect effect through both internal and external organizational learning as the intermediary variable is 0.367, among which the intermediary effects caused by internal learning is 0.260 (0.460×0.566) and the one caused by external learning is 0.107 (0.332×0.323). Since, 0.260 is greater than 0.107, it shows that the intermediary affect of internal learning is higher. Therefore, the total effect of institutional implementation acted on longitudinal synergy effect is 0.898.

Research finding are as follow: (1) Compared with the institutional environment, institutional implementation is with higher total effect for synergy effect. (2) The institutional environment had no direct effect on synergy effect but indirect influence through the external learning. (3) Compared with external learning, intermediary effect of internal learning is more apparent.

CONCLUSION

Based on the comparison of the above conclusion, extension can draw as following three:

- Organizational learning has obvious intermediary role in the process of institutional innovation affect on synergy effect. That is to say, there exists a path of

“institution-organization-performance” which is one path that can generate synergistic effect. Organizational learning plays an important role in the process of synergy effect caused by institutional innovation. Therefore, Suggestions to university spin-offs is to emphasize the importance of organizational learning, strengthen the exchange and interaction with the main cooperation subjects and organizations industry chain, promoted the innovation ability of the organization by learning

- The directly affect and the intermediation of internal learning acted on synergies effect are more apparent. The recommendation is that internal learning is the main methods of sharing and inheriting information, experience and skills in organization. As a result, university spin-offs should attach importance to internal learning which focused on learning in the individual and among departments level and establish the learning organization. It is of great significance to improve the organization's stability and organization efficiency
- External institutional environment would not take directly impact on organizational behavior and organizational performance but some indirect effect. Thus, it proved that the impact of environment on the organization is manifold. In the process of the implementation of the institution innovation, the government should act as "the first action group" and make direct innovation policy, as well as to providing the public products "institutional environment". These behaviors have the catalytic effect for synergy innovation of university-industry cooperation organization

REFERENCES

- Chen, G.Q. and X.H. Wang, 2012. The moderating effect of environmental dynamism on the relationship between organizational learning and performance. *R&D Manage.*, 24: 52-59.
- Hao, Y., 2005. A study of institutional alternative for hi-tech industry development of China's universities. Ph.D. Thesis, Huazhong University of Science and Technology, Wuhan, China.
- Jia, Y.W. and L.M. Jia, 2012. Empirical study with SEM on sustainable development driving factors of technological firms based on university. *J. Beijing Jiaotong Univ.*, 36: 143-148.
- Jia, Y. and H. Zhang, 2013. Study on the synergy mode of university-industry collaboration based on the view of institutional innovation. *China Higher Educ. Res.*, 1: 37-39.
- Li, Y.H. and Y. Ma, 2001. The theory grasp of interactions between technology innovation and institution innovation the comparison between Marxism economics and New institutional economics. *Econ. Sci.*, 1: 87-93.
- Li, X.H., 2011. Collaborative innovation is the best form and pathway of improving the independent innovation ability and efficiency. *Science/Tech-China Daily*, September 22, 2011.
- MacKinnon, D.P., C.M. Lockwood, J.M. Hoffman, S.G. West and V. Sheets, 2002. A comparison of methods to test mediation and other intervening variable effects. *Psychol. Methods*, 7: 83-104.
- Schein, E.H., 1985. *Organizational Culture and Leadership*. Jossey-Bass, San Francisco.
- Wang, Y.L. and A.D. Ellinger, 2011. Organizational learning: Perception of external environment and innovation performance. *Int. J. Manpower*, 32: 512-536.
- Wang, F.R. and Y.J. Fang, 2013. An empirical study on the relationship between organizational culture and technological innovation performance based on organization al learning. *R&D Manage.*, 25: 36-43.
- Wu, M.L., 2009. *Structural Equation Model the Application and Operation of Amos*. Chongqing University Press, Chongqing, China, ISBN-10: 9571156876.
- Xie, H.M. and Z.T. Han, 2005. Organizational learning and organizational performance: Is innovation a missing link? *Sci. Res. Manage.*, 26: 1-10.
- Xie, H.M., Z.L. Ge and C. Wang, 2008. On the relation of social capital, organizational learning and organizational innovation: A experiential study of companies in pearl river delta region of China. *J. Ind. Eng. Eng. Manage.*, 1: 5-10.
- Xu, X.Y. and Y.J. Xu, 2008. The study on synergy degree of Enterprise technology innovation, system innovation and continuous growth. *Dong Yue Tribune*, 29: 80-85.
- Xue, J. and H.Q. Ma, 2013. Suggestions on scientific evaluation and 2011 project interview the Chen Maozhang the academician of CAE and professor of BUAA. *Chin. Univ. Technol. Transfer*, 3: 4-9.
- Zhou, Y.Q. and Y. Li, 2005. Research on the relationship of organizational learning, capability and choice of innovation type. *Study Sci. Sci.*, 23: 525-530.