

Fuzzy PI Controller Based Grid-Connected PV System

M. Sreedevi and P. Jenio Paul
Anna University, Tamil Nadu, India

Abstract: In this study presents a single-phase five-level Photo-Voltaic (PV) inverter topology for grid-connected system. The photo-voltaic arrays are connected to five-level inverter through the DC-DC boost converter. By implementing maximum power point tracking algorithm are producing more power from PV array. The DC power from the PV array is boosted by using the DC-DC boost converter. The boosted DC supply is applied to PWM inverter which is controlled by FUZZY-PI controller. The output of inverter is AC supply, it's connected to grid. A digital proportional-integral-derivative current control algorithm is implemented in MATLAB version 7.5. For dynamic performance of the grid current will be almost sinusoidal. The total harmonic distortion produce by inverter will be less. The results are compared with the digital proportional-integral current control algorithm in single-phase five-level photo-voltaic inverter.

Key words: Photovoltaic array, DC-DC boost converter, FUZZY-PI current controller, PWM inverter, MATLAB/Simulink, India

INTRODUCTION

In recent year, the power demand is more. Resolve this problem and to reduce the demand of the power. Researchers are using renewable energy source. Because they do not create pollution, long effective life and maintenance free. The most popular energy source is solar energy and wind energy. The solar energy can be harnessed either by deriving energy directly from sunlight. There are three methods; solar thermal technology, photo-voltaic energy conversion technology and solar hydrogen gas production technology. The photo-voltaic energy conversion technology is the most useful way of harnessing solar photo-voltaic cells (Selvaraj and Rahim, 2009). The photo-voltaic cells are generating DC electricity without involvement of any mechanical generators (Tsai *et al.*, 2008). The electrical energy output from solar PV cells depends upon the intensity of sunlight incident on conversion efficiency and temperature of operation. Energy conversion devices are used to convert sunlight to electricity by the use of the photo-voltaic effect. The solar cells are interconnected in certain series/parallel combinations to form modules. A combination of suitable modules constitutes an array. The maximum power point tracking algorithm is implemented to maximum energy obtained for PV arrays. The DC-DC boost converter is nothing but step up converter. It is the low level of dc converted to high level of dc voltage (Ramabadran and Mathur, 2009). The PV array output voltage is low, it is converted to high level voltage through DC-DC boost converter. The high level of dc voltage to applied to multilevel inverter. The inverter is

used to conversion of DC to AC voltage. The three common topologies for multilevel inverters are as follows: diode clamped, capacitor clamped and cascaded H-bridge inverter. In addition, several modulation and control strategies have been developed or adopted for multilevel inverters including the following: Multilevel Sinusoidal (PWM), multilevel selective harmonic elimination and space-vector modulation. In this study presents a five-level PWM inverter whose output voltage can be represented in the following five levels: zero, $+1/2V_{dc}$, $+V_{dc}$, $-1/2V_{dc}$ and $-V_{dc}$. This inverter topology uses two reference signals, instead of one reference signal to generate PWM signals for the switches. Both the reference signals V_{ref1} and V_{ref2} are identical to each other except for an offset value equivalent to the amplitude of the carrier signal $V_{carrier}$. Because the inverter is used in a PV system, a Proportional-Integral-Derivative (PID) current control scheme is employed to keep the output current sinusoidal and to have high dynamic performance under rapidly changing atmospheric conditions and to maintain the power factor at near unity (Reemmer, 2007). Simulation results are presented to validate the proposed inverter configuration. The inverter offer lower Total Harmonics Distortion (THD), improved step response and quality of power.

PHOTOVOLTAIC MODELS

Solar cell is basically a p-n junction fabricated in a thin wafer or layer of semiconductor. The electromagnetic radiation of solar energy can be directly converted

electricity through photovoltaic effect (Rahim *et al.*, 2009). Being exposed to the sunlight, photons with energy greater than the band-gap energy of the semiconductor are absorbed and create some electron-hole pairs proportional to the incident irradiation (Ramabadran and Mathur, 2009). Under the influence of the internal electric fields of the p-n junction, these carriers are swept apart and create a photocurrent which is directly proportional to solar insolation. PV system naturally exhibits a nonlinear I-V and P-V characteristics which vary with the radiant intensity and cell temperature.

Solar cell model: A general mathematical description of I-V output characteristics for a PV cell has been studied for over the past four decades. Such an equivalent circuit based model is mainly used for the MPPT technologies (Hassaine *et al.*, 2007). The equivalent circuit of the general model which consists of a photo current, a diode, a parallel resistor expressing a leakage current and a series resistor describing an internal resistance to the current flow is shown in Fig. 1. The voltage-current characteristic equation of a solar cell is given as:

$$I = I_{PH} - I_S [\exp (q (V + IR_S) / kT_C A) - 1] - (V + IR_S) / R_{SH} \quad (1)$$

Where:

- I_{PH} = A light-generated current or photocurrent
- I_S = The cell saturation of dark current
- $q (=1.6 \times 10^{-19} C)$ = An electron charge
- $k (=1.38 \times 10^{-23} J/K)$ = A Boltzmann's constant
- T_C = The cell's working temperature
- A = An ideal factor
- R_{SH} = A shunt resistance
- R_S = A series resistance

The photocurrent mainly depends on the solar insolation and cell's working temperature which is described as:

$$I_{PH} = [I_{SC} + K_1 (T_C - T_{ref})] \lambda \quad (2)$$

Where:

- I_{SC} = The cell's short-circuit current at a 25°C and 1 kW m⁻²
- K_1 = The cell's short-circuit current temperature coefficient
- T_{ref} = The cell's reference temperature
- λ = The solar insolation in kW m⁻²

On the other hand, the cell's saturation current varies with the cell temperature which is described as:

$$I_S = I_{RS} (T_C / T_{ref})^3 \exp [qE_G (1/T_{ref} - 1/T_C) / kA] \quad (3)$$

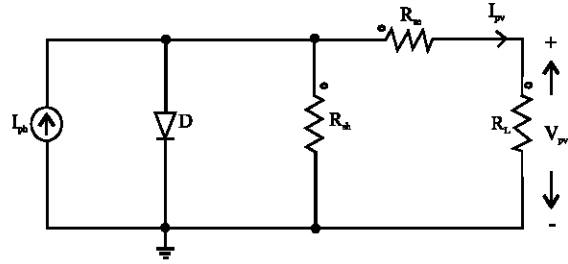

Fig. 1: Single PV cell

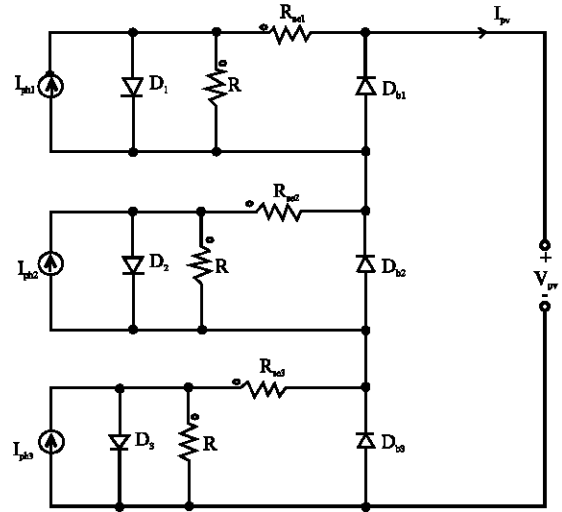

Fig. 2: Series connected PV Array with bypass diodes

Where:

- I_{RS} = The cell's reverse saturation current at a reference temperature and a solar radiation
- E_G = The band-gap energy of the semiconductor used in the cell (Hamrouni and Cherif, 2007)

PV array model: Since a typical PV cell produces <2 W at 0.5 V approximately, the cells must be connected in series-parallel configuration on a module to produce enough high power. A PV array is a group of several PV modules which are electrically connected in series and parallel circuits to generate the required current and voltage (Agelidis *et al.*, 1997). The equivalent circuit for the solar module arranged in N_p parallel and N_s series is shown in Fig. 2. The equivalent circuit for the solar module and maximum power point algorithm is implemented to MATLAB (Carrasco *et al.*, 2006). The equivalent circuit is described on the following equation:

$$I = N_p I_{PH} - N_p I_S [\exp (qV / N_s kT_C A) - 1] \quad (4)$$

PROPOSED INVERTER TOPOLOGY

The proposed inverter topology consists of PV array, DC-DC boost converter, five-level H-bridge

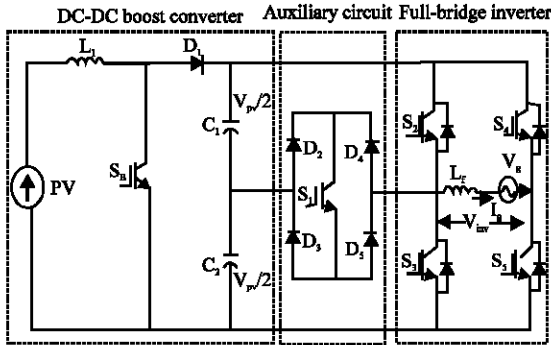

Fig. 3: Proposed inverter topology

inverter, grid-connected (Fig. 3). The PV array is generated dc supply through solar energy, its low level dc output. In low level dc output step up high level voltage through DC-DC boost converter with dc bus capacitors. The step up ratio is 1:2. The five-level inverter is used to conversion of DC to AC voltage. The ac voltage is connected to grid-system i.e., utility feeder through filtering inductor. The injected current must be sinusoidal with low harmonic distortion. The load is considered as resistive and inductive load.

MODULATION TECHNIQUE AND OPERATION OF PROPOSED INVERTER

A sinusoidal PWM is used, it is one of the most efficient method. The proposed PWM modulation strategy is shown in Fig. 3. Two reference signals V_{ref1} and V_{ref2} and triangular carrier signal $V_{carrier}$ were used to generate the PWM switching signals. The modulation index M_a is maintained between 0-1. The output voltage produced by comparison of the two reference signals and the carrier signals can be expressed as fourier series coefficient:

$$V_0(\theta) = A_0 + \sum_{n=1}^{\infty} (A_n \cos n\theta + B_n \sin n\theta) \quad (5)$$

n-even number, so $A_0 = 0, B_n = 0$

$$V_0(\theta) = \sum_{n=1,3}^{\infty} (A_n \cos n\theta) \quad (6)$$

$$A_n = \frac{4V_{pv}}{n\pi} \sum_{m=1}^p [(-1)^m \sin(n\alpha_m)] \quad (7)$$

Where:

m = Apulse number

α = The phase angle displacement

In this research, two reference modulation techniques is incorporated into the sinusoidal PWM technique to produce PWM switching signals for full-bridge inverter switches and auxiliary switch.

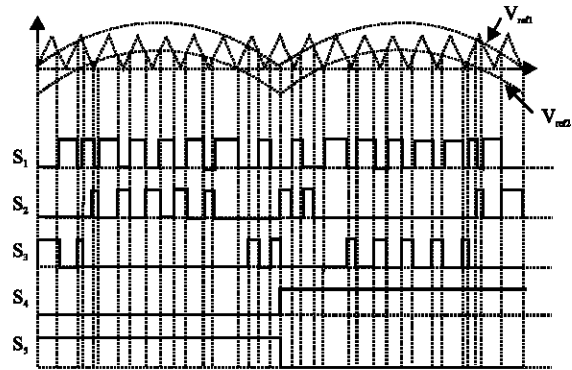

Fig. 4: Switching pattern for the single-phase five level inverter

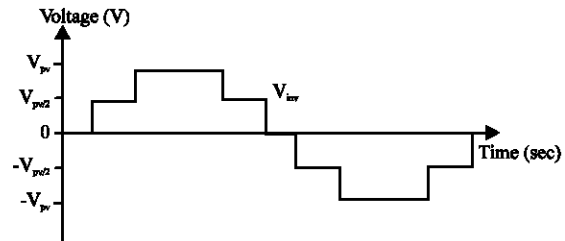

Fig. 5: Ideal five-level inverter output voltage V_{inv}

Table 1: Inverter output voltage during S_1 - S_5 switch on and off

S_1	S_2	S_3	S_4	S_5	V_{inv}
ON	OFF	OFF	OFF	ON	$+V_{pv}/2$
OFF	ON	OFF	OFF	ON	$+V_{pv}$
OFF	OFF	OFF	ON	ON	-
	or	or	or	or	0
	ON	ON	OFF	OFF	-
ON	OFF	OFF	ON	OFF	$-V_{pv}/2$
OFF	OFF	ON	ON	OFF	$-V_{pv}$

The proposed inverter is generate five-level output voltage i.e., $0, +V_{pv}/2, +V_{pv}, -V_{pv}/2$ and $-V_{pv}$. The auxiliary circuit is consists of four diodes and switch S_1 , it is generate half level of PV supply voltage i.e., $+V_{pv}/2, -V_{pv}/2$. The five-level inverter output voltage V_{inv} is shown in Fig. 4 and 5. Table 1 shows the level of V_{inv} during S_1 - S_5 switch ON and OFF.

PROSED CONTROL SYSTEM AND ALGORITHM

The proposed inverter is used to grid-connected PV system. So the power is injected to the grid, it is maintain the power factor at near unity. As the irradiance level is inconsistent throughout the day, the amount of electric power generated by the solar modules is always changing with weather conditions. To overcome this problem, Maximum Power Point Tracking (MPPT) algorithm is used. The perturb and observe algorithm is used to extract

Table 2: Rule base with five membership functions

$\Delta\omega/\Delta\omega$	NB	NS	ZO	PS	PB
NB	NB	NB	NB	NS	ZO
NS	NB	NS	NS	ZO	NS
ZO	NB	NS	ZO	PS	PB
PS	NS	ZO	PS	PS	PB
PB	ZO	PS	PB	PB	PB

maximum power from the PV modules. The feedback controller used in this application utilizes the FUZZI- PI algorithm there is separate inverter topology to controlled. The proposed inverter is the current injected into the grid, grid current I_g is sensed and feed back to a comparator which compares it with the reference current I_{ref} . I_{ref} is obtained by sensing the grid voltage and converting it to reference current and multiplying it with constant m . This is to ensure that I_g is in phase with grid voltage V_g and always at near-unity power factor. All the algorithm are developed in C++ language and its implemented to MATLAB version 7.5. The PI algorithm:

$$u(t) = K_p e(t) + K_i \int_0^t e(\tau) d\tau \quad (8)$$

Where:

- $u(t)$ = Control signal
- $e(t)$ = Error signal
- t = Continuous-time-domain time variable
- τ = Calculus variable of integration
- K_p = Proportional-mode control gain
- K_i = Integral-mode control gain
- K_d = Derivative-mode control gain

The process of fuzzy logic controller design includes the following steps:

Fuzzification: The process of representing inputs as suitable linguistic variables.

Decision making: The appropriate control action to be carried out needs to be based on knowledge.

Defuzzification: The process of converting fuzzified outputs into crisp values. A fuzzy logic controller initially converts the crisp errors and changes in error variables into fuzzy variables. Then they are mapped into linguistic labels. Membership functions are associated with each label as shown in the Table 2.

The linguistic labels are divided into seven groups: nl negative large, nm-negative medium, ns-negative small, z-zero, ps-positive small, pm-positive medium, pl-positive large. Each of the inputs and output contains membership functions with all seven linguistics.

SIMULATION RESULTS

The proposed system was performed by using MATLAB. The output of the PV array is 115 V and the

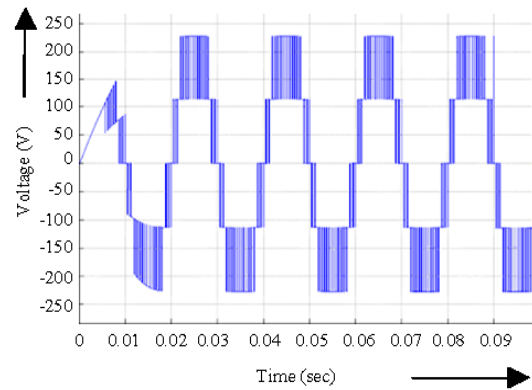

Fig. 6: Proposed inverter output voltage

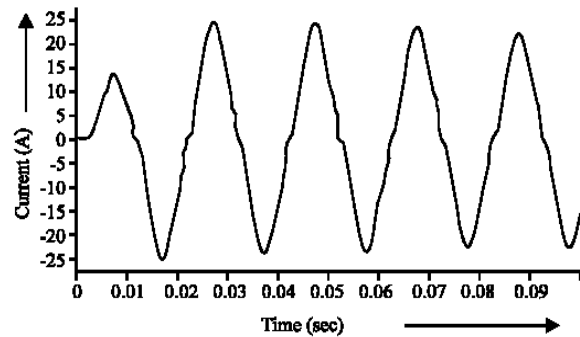

Fig. 7: Grid current

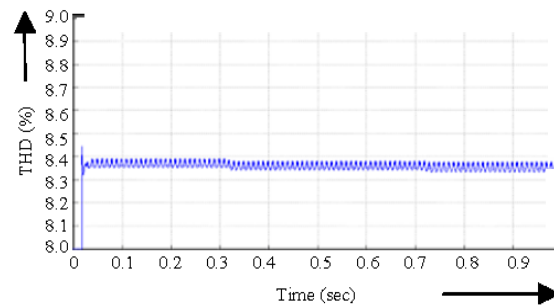

Fig. 8: THD in FUZZY PI control scheme

voltage is applied DC-DC boost converter from PV array. Researchers are getting output voltage from DC-DC boost converter 230 V and here see five-level inverter inverts DC supply to AC supply. The outputs of the inverter are 230 V and 50 Hz for voltage and frequency, respectively. The simulation five-level output as shown in Fig. 6. The grid current is almost a pure sine wave as shown in Fig. 7. The grid current is variable one, depend up on load. The total harmonic distortion can be analyzed in PI and FUZZY PI current control scheme. The FUZZY-PI current controller was produce low harmonic distortion and improved sudden step response compare to PI current controller as shown in Fig. 8 and 9. The power factor can be calculated using mathematical calculation. The power factor is 0.96. So the power factor is near unity.

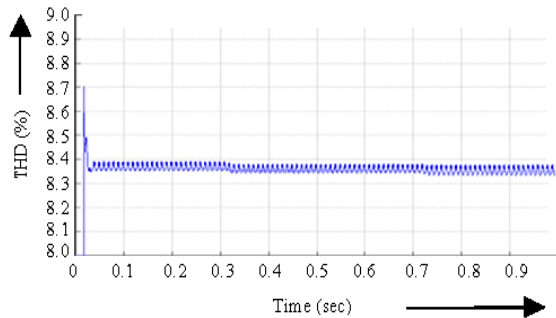

Fig. 9: THD in PI control scheme

CONCLUSION

This study presents a single-phase five-level Photovoltaic (PV) inverter topology for grid-connected application. The photovoltaic models, operation of proposed inverter topology, control system algorithm, modulation technique and simulation results were analyzed. The control system algorithms are developed in C++ language and it's implemented in MATLAB version9. The FUZZ-PI current controller was produce low harmonic distortion and improved sudden step response compare to PI current controller. The grid current is almost sine wave and the power factor also near unity. Further, in the system will be implemented to real time application.

REFERENCES

Agelidis, V.G., D.M. Baker, W.B. Lawrance and C.V. Nayar, 1997. A multilevel PWM inverter topology for photovoltaic applications. Proceedings of the IEEE International Symposium on Industrial Electronics, July 7-11, Guimaraes, Portugal, pp: 589-594.

Carrasco, J.M., L.G. Franquelo, J.T. Bialasiewicz, E. Galvan and R.C.P. Guisado *et al.*, 2006. Power-electronic systems for the grid integration of renewable energy sources: A survey. IEEE Trans. Ind. Electron., 53: 1002-1016.

Hamrouni, N. and A. Cherif, 2007. Modeling and control of a grid connected photovoltaic system. Revue des Energies Renouvelables, 10: 335-344.

Hassaine, L., E. Olias, M. Haddadi and A. Malek, 2007. Asymmetric SPWM used in inverter grid connected. Revue des Energies Renouvelables, 10: 421-429.

Rahim, N.A., J. Selvaraj and K. Chaniago, 2009. A novel PWM multilevel inverter for PV application. IEICE Electron. Express, 6: 1105-1111.

Ramabadran, R. and B. Mathur, 2009. MATLAB based modelling and performance study of series connected SPVA under partial shaded conditions. J. Sustainable Dev., 2: 85-94.

Reemmer, B.R., 2007. DC to DC conversion boost converter design. Team 5, March 30, 2007. <http://www.egr.msu.edu/classes/ece480/capstone/spring/group05/docs/AppNote-reemmerb.pdf>.

Selvaraj, J. and N.A. Rahim, 2009. Multilevel inverter for grid-connected PV system employing digital PI controller. IEEE Trans. Ind. Electron., 56: 149-158.

Tsai, H.L., C.S. Tu and Y.J. Su, 2008. Development of generalized photovoltaic model using MATLAB/SIMULINK. Proceedings of the World Congress on Engineering and Computer Science, Oct. 22-24, San Francisco, USA., pp: 1-6.