

Study of Seven-Lump Kinetic Model in the Fluid Catalytic Cracking Unit

Mehran Heydari, Habib AleEbrahim and Bahram Dabir
Department of Chemical Engineering, Amir Kabir University of Technology,
424, Hafez Ave, Tehran, P.O. Box 15875-4413, Iran

Abstract: Problem statement: The effective simulation of the Fluid Catalytic Cracking (FCC) operation requires a good understanding of many factors such as, reaction kinetic, fluid dynamics and feed and catalyst effects. **Approach:** In this model the reactor has been considered as an isothermal riser. The reactions in the riser occur with the fluid and the solids in ideal plug flow. Because of complication of the catalytic cracking mechanism and existence of multi-components in the feed, to decrease the calculation content in the kinetic models, the reactants and products have been considered as a set of hydrocarbons, so these models are called “Lumped Models”. **Results:** To simulate the FCC riser, the seven-lump model involved residual oil, heavy lump, light lump, liquefied petroleum gas, gasoline, dry gas and coke (to predict the feed conversion and the product distribution) has been developed. **Conclusion:** Simulation studies are performed to investigate the effect of changing various process variables, such as temperature and residence time. Comparison of simulation results with industrial ones shows that the simulation has been achieved accurately.

Key words: FCC, riser reactor, riser simulation, lump kinetic model, hydrodynamic model

INTRODUCTION

The Fluid Catalytic Cracking (FCCU) is the primary conversion unit in oil refinery operation. The Fluid Catalytic Cracking (FCC) unit is one of the most important processes in the petroleum refining industry. Heavy petroleum fractions are catalytically cracked to lower molecular weight products. In the FCCU riser, lift steam pushes the dense catalyst bed upward from the riser base to the feed injection point. The feed enters as liquid droplets along with atomizing steam, contact the hot catalyst and rapidly evaporates. As the suspension of catalyst powder in reactant gases rises upward, the gas is cracked to lighter hydrocarbons (gasoline and light gases) and coke. The coke is deposited on the catalyst, which is transported out of the riser and into the regenerator, where the coke is burned off the catalyst in a combustion environment. The hot regenerated catalyst is then reinjected into the base of the riser (Pugsley and Dalai, 2004). Because of generation of gas by the cracking reactions, the gas velocity increases from 4.5-6 m sec⁻¹ near the riser base to 15-20 m sec⁻¹ at the riser exit. New world trends in product demands to meet more severe legislation about fuel composition, raise the significance of controlling the FCC product selectivity. The complexity of gas oil mixtures, which are the typical FCC feeds, makes it

extremely difficult to characterize and describe the inherent kinetics at a molecular level. In this way similar components are grouped into a few “cuts” or “lumps. Therefore, the study of the reactions involved in the catalytic cracking process has followed the lumping methodology. The number of lumps of the proposed models for catalytic cracking reactions has been consecutively increasing to obtain a more detailed prediction of product distribution (Bollas, 2007). In the first kinetic model (3-lump), proposed by Weekman (1968), reactants and products were lumped into three major groups: Gas oil, gasoline and light gas plus coke. Yen and Yu (1988); Lee *et al.* (1989) took one step forward by dividing the light gas plus coke lump into two different lumps C₁-C₄ gas and coke, developing the first 4-lump models for fluid catalytic cracking. Advancing the lumping methodology, Corella and Frances (1991) developed a 5-lump models, in which the gas-oil lump was divided into its heavy and light fractions. Dupain *et al.* (2006) simplified the 5-lump model of Corella and Frances for the specific case of the catalytic cracking of aromatic gas oil, by reducing the reactions involved in the lumping scheme. Another 5-lump model was developed by Larocca *et al.* (1990) in which the 3-lump model of Weekman was modified by splitting the gas oil lump into aromatic, paraffinic and naphthenic lumps. Ancheyta *et al.* (1999)

Corresponding Author: Mehran Heydari, Department of Chemical Engineering, Amir Kabir University of Technology, 424, Hafez Ave, Tehran, P.O. Box 15875-4413, Iran Tel: +989121752593

followed a different approach in their 5-lump models development, in which they considered the gas oil as one lump, but divided the gas lump into two lumps (liquefied product gas and dry gas). Oliveira and Biscaia (1989) (emphasizing in the catalytic cracking of gasoline and paraffinic gas oils). Hagelberg *et al.* (2002) expanded the 5-lump model of Ancheyta-Juarez *et al.* (1999) to an 8-lump model by dividing the gasoline fraction into paraffins, olefins, naphthenes and aromatics. The more advanced model was proposed by Jacob *et al.* (1976) which included 10 lumps (light and heavy gas oil paraffinic, naphthenic and aromatic rings and substituent). On the basis of the 10-lump model of Jacob *et al.* (1976); Ellis *et al.* (1998) developed a more advanced model capable of predicting the light gas product slate, using empirical algebraic equations. With presence of the high efficiency feed injection system in modern FCC units cause all cracking in the riser occur during the short time about 1-5 sec (Arandes and Lasa, 1992; Arbel *et al.*, 1995; Han and Chung, 2001; Ali and Rohani, 1997), so in the present research, a one-dimensional isothermal for the FCC unit riser has been developed that combines a predicative riser hydrodynamic model with a seven-lump kinetic model. The model has been validated by comparison with industrial FCC unit riser conversion and yield data available from literature (Mu and Wang, 2003).

Mathematical modeling: The model is based on the schematic flow diagram presented in Fig. 1. The upper fluidized bed immediately above the riser acts as a disengaging chamber where vapor products and heavy components are separated from the catalyst using stripping steam. The only effect of the stripping process is to remove hydrocarbon gases adsorbed inside the pellets before the spent catalyst is sent to the regenerator. Fresh gas oil is brought into contact with the hot regenerated catalyst at the entrance of the riser which leads to the vaporization of gas oil. The inlet zone is considered to be the most complex part of the riser. This is attributed to the presence of high turbulence, high temperature and concentration gradients and flow inhomogeneity. To maintain a good balance between kinetics and applicability of the model, it has been considered a model with seven lumps for predicting the behavior of the unit. The model is divided into VR (vacuum.residue, >500°C) and VGO (vacuum gas oil, 350~500°C), HFO (heavy fuel oil, 350~500°C), LFO (light fuel oil, 200~350°C), G (gasoline, C₅~200°C), S₁ (liquefied petroleum gas, C₃~C₄), S₂ (dry gas C₁~C₂) and C (coke) according to their distillation ranges (Ou-Guan and Hong-Ye, 2006).

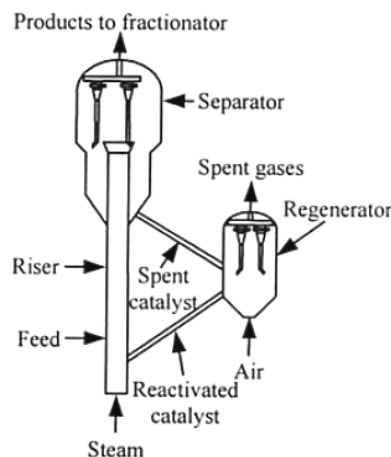

Fig. 1: Schematic diagram of catalytic cracking unit

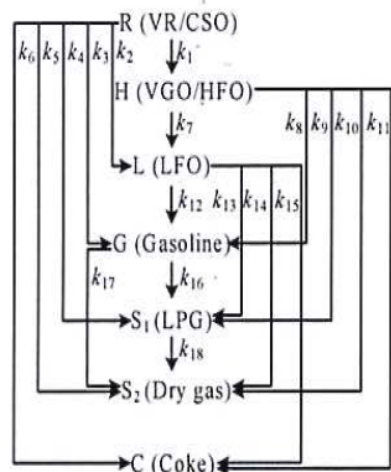

Fig. 2: Seven-lump reaction scheme for catalytic cracking unit

Figure 2 shows the reaction scheme diagram for catalytic cracking unit. The reactions involved in the reaction network are described by Eq. 1-7:

$$\frac{dy_1}{dx} = \varnothing(t_c) f(C_{A_{th}}) cte[-(k_1 + k_2 + k_3 + k_4 + k_5 + k_6)] y_1 \quad (1)$$

$$\frac{dy_2}{dx} = \varnothing(t_c) f(C_{A_{th}}) cte[(v_{th} k_1 y_1) - (k_7 + k_8 + k_9 + k_{10} + k_{11}) y_2] \quad (2)$$

$$\frac{dy_3}{dx} = \varnothing(t_c) f(C_{A_{th}}) cte[v_{h1} k_2 y_1 + v_{h1} k_7 y_2 - (k_{12} + k_{13} + k_{14} + k_{15}) y_3] \quad (3)$$

$$\frac{dy_4}{dx} = \varnothing(t_c) f(C_{Ath}) cte [v_{rg} k_3 y_1 + v_{hg} k_8 y_2 + v_{lg} k_{12} y_3 - (k_{16} + k_{17}) y_4] \quad (4)$$

$$\varnothing(t_c) = \frac{1}{(1 + Bt_c^\gamma)}$$

$$\frac{dy_5}{dx} = \varnothing(t_c) f(C_{Ath}) cte [v_{rsi} k_4 y_1 + v_{hsi} k_9 y_2 + v_{isi} k_{13} y_3 + v_{gsi} k_{16} y_4 + k_{18} y_5] \quad (5)$$

$$\frac{dy_6}{dx} = \varnothing(t_c) f(C_{Ath}) cte [v_{rs2} k_5 y_1 + v_{hs2} k_{10} y_2 + v_{is2} k_{14} y_3 + v_{gs2} k_{17} y_4 + v_{sis2} k_{18} y_5] \quad (6)$$

$$\frac{dy_7}{dx} = \varnothing(t_c) f(C_{Ath}) cte [v_{rc} k_6 y_1 + v_{hc} k_{11} y_2 + v_{lc} k_{15} y_3] \quad (7)$$

Where:

- X = Represents dimensionless distance of the riser
- y₁ = The weight fraction of residual oil
- y₂ = Of heavy fuel oil
- y₃ = Of light fuel oil
- y₄ = Of gasoline
- y₅ = Of liquefied petroleum gas
- y₆ = Of dry gas
- y₇ = Of coke

The factors v_{ij} are the ratios of the molecular weight of lump i over lump j and are used as stoichiometric coefficients for the reaction of lump i to j, in order to satisfy the global mass balance. The constants of the Eq. 1-7 can be expressed as follows:

$$f(C_{Ath}) = \frac{1}{(1 + K_h C_{Ath})}$$

$$cte = \frac{PMW}{RTS_{wh}}$$

$$S_{wh} = G_v \varepsilon / \rho_c L$$

Where:

- C_{Ath} = Represents wt% of aromatic in residual oil
- K_h = 0.128 represents the heavy aromatic ring adsorption coefficient
- S_{wh} = Represents true weight hourly space velocity (Mu *et al.*, 2003)

In this scheme, the decay of the catalyst activity due to coke deposition is represented by a function, $\varnothing(t_c)$ which depends on catalyst residence time, t_c:

where, B = 162.15, $\gamma = 0.76$ reported by Jacob and Gross (Jacob and Gross, 1976).

In order to develop a mathematical model for this system the following assumptions are introduced:

- One-dimensional ideal plug flow reactor prevails in the riser without radial and axial dispersion
- The reactor has been considered as an isothermal riser
- Feed viscosity and heat capacities of all components are constant
- The coke deposited on the catalyst does not affect the fluid flow
- The limitation of the model is that lumps proposed are not separated by chemical type with the parameters depending on feedstock and catalyst properties
- Instantaneous vaporization occurred in entrance of riser
- All cracking reactions are considered to take place in the riser

MATERIALS AND METHODS

The specifications of the commercial riser reactor and operation conditions used in this study and The kinetic parameters for cracking reactions from the literature can be found in Table 1-4, respectively. (Ou-Guan and Hong-Ye, 2006).

Table 1: Riser dimensions

	Length (m)	Diameter (m)
Riser reactor	2.8	0.07

Table 2: Average molecular weight

Species	Mw (kg kmol ⁻¹)
Residual lump	950.0
Heavy lump	386.0
Light lump	229.0
Gasoline	117.8
LPG	46.7
Dry gas	18.4
Coke	400.0

Table 3: Operation conditions

Reaction temperature	773 (k)
Catalyst to oil ratio	3.57
Reaction pressure	150 (kPa)
Catalyst density	840 (kg m ⁻³)
Gas density	5.3 (kg m ⁻³)
Gas velocity	2.5 (m sec ⁻¹)

Table 4: Kinetic parameters of seven-lumps at 500°C

Reaction	Rate constant ($m^3 (kg \cdot cat \cdot h)^{-1}$)	Activation energy ($kJ \cdot mol^{-1}$)
RFO→HFO	$K_1: 14.93$	50.73
RFO→LFO	$K_2: 5.78$	50.73
RFO→G	$K_3: 11.69$	50.73
RFO→S ₁	$K_4: 3.59$	16.15
RFO→S ₂	$K_5: 0.35$	16.15
RFO→C	$K_6: 11.55$	16.15
HFO→LFO	$K_7: 5.78$	50.73
HFO→G	$K_8: 0.94$	46.24
HFO→S ₁	$K_9: 0.135$	59.75
HFO→S ₂	$K_{10}: 0.0135$	59.75
HFO→C	$K_{11}: 0.3272$	59.75
LFO→G	$K_{12}: 0.5742$	46.24
LFO→S ₁	$K_{13}: 0.0086$	59.75
LFO→S ₂	$K_{14}: 0.0009$	59.75
LFO→C	$K_{15}: 0.0596$	59.75
G→S ₁	$K_{16}: 0.0003$	78.49
G→S ₂	$K_{17}: 0.0001$	78.49
S ₁ →S ₂	$K_{18}: 0.0033$	59.75

Table 5: Comparison of this study predicted results with industrial plant data

	Plant	Calc.	Deviation (%)
Residual lump (wt%)	7.80	7.1	-8.9
Heavy lump (wt%)	4.75	2.7	-43.1
Light lump (wt%)	19.71	16.8	-14.7
Gasoline (wt%)	35.98	33.2	-7.7
LPG (wt%)	19.49	26.3	34.0
Dry gas (wt%)	4.14	5.3	28.0
Coke (wt%)	8.13	8.6	0.7

RESULTS

In this study, the simulation results are presented and discussed. Table 5 shows the predictions of model are compared with all of exist plant data, According to Table 5 a good agreement between the plant data and the model prediction is observed. Figure 3 shows the concentration profiles along the axial coordinate in the riser. Figure 4 predicts that much of the gas oil conversion occurs in the first 5m of the riser, which is correspondence with other FCC unit riser simulation (Ali *et al.*, 1997; Berry *et al.*, 2004; Kenny *et al.*, 1994; Martin *et al.*, 1992; Theologos and Markatos, 1993; Derouin *et al.*, 1997) and commercial data (Ou-Guan and Hong-Ye, 2006). There are a number of reasons for this, First, the bottom zone of the riser has a high catalysts concentration, In addition, this catalysts just have been reintroduced from the regenerator, has high activity than it does at higher axial location in the riser, Further more, the concentration of gas oil vapor is highest at the base of the riser in compared to that at higher axial locations, where reaction and molar expansion decrease the gas oil concentration.

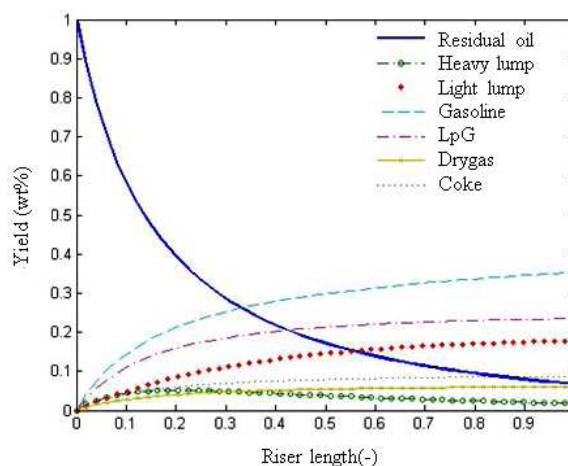

Fig. 3: Steady-state concentration profiles in the riser

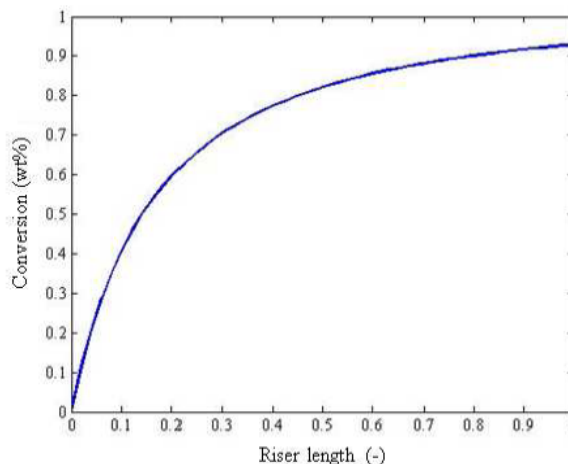

Fig. 4: Conversion (wt%) versus riser length

Thus the reaction rate of gas oil to products is greatest at the bottom of the riser, contributing to rapid conversion, as mentioned before, most of the cracking reactions occur in the initial section of the riser.

DISCUSSION

Figure 5 shows the effect of changing inlet temperatures on gasoline yield along the axial coordinate in the riser. According to Fig. 5, because of high conversion in the initial section of riser, with increasing of inlet temperatures, gasoline yield increased, but after the gasoline yield passed through a maximum value, because of coke deposition, decreasing of the gasoline yield is evident. The highest yield was obtained at 1075 (k), It should be noted that this maximum point is a function of the feed quality, catalyst type and reaction temperature.

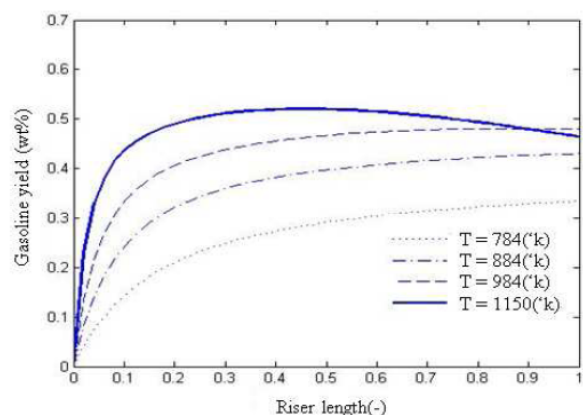

Fig. 5: Effect of changing inlet temperatures on gasoline yield along the axial coordinate in the riser

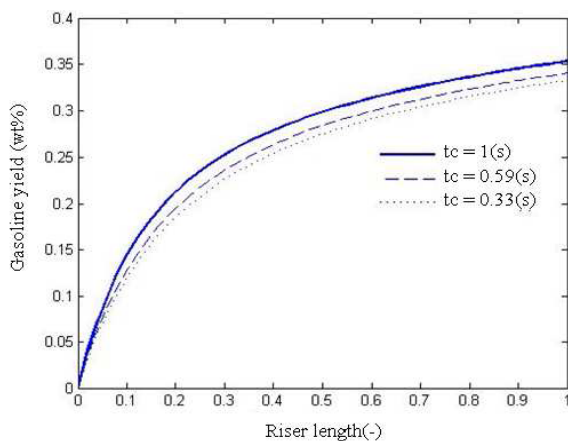

Fig. 6: Effect of changing residence time on gasoline yield along the axial coordinate in the riser

Figure 6 shows that increasing of residence time, the gasoline yield increases, because the short residence time minimizes gasoline cracking and coke yield (Ellis *et al.*, 1998; Kasat *et al.*, 2002; Bollas, 2002). As reaction center of the products and heat carrier in the process, catalyst should be paid more attention to, especially the catalyst circulation between reactor and regenerator. A majority of heat required for feedstock vaporization and endothermic reactions in the FCC process comes from burning the deposited coke on spent catalyst surface. The more coke produced in the process, the more steam should be needed for spent catalyst hydrocarbon stripping. Hence precise coke formation prediction is crucial. The separated lump of coke in the model ensures precise prediction of coke. The advantage of model is the ability to predict LPG, dry gas and coke yields separately which satisfies the

users demand and is fit for commercial use. At the point of gas compression, the accurate estimation of lumps by the model gives us guidance to design gas compressor. All the above mentioned conditions demonstrate the significance of lump separation during the model establishment. Component concentration profiles along the riser can be easily described by the model. In this study, the ordinary differential equations Eq. 1-7 must be solved by Runge-Kutta order 4, because the equations are not too stiff, so it has been developed a Matlab code for this purpose. The proposed model is suitable for off-line process simulation as well as on-line application, which is the basis of process optimization and advanced process control.

CONCLUSION

A one-dimensional model of the riser section of catalytic cracking unit has been developed by combining a one dimensional predictive riser hydrodynamic model with the seven-lump reaction kinetics model of XU Ou-Guan and Hong-Ye (2006). Effect of the operating conditions on the system behavior has also been studied. The model predictions of the gas oil conversion, product yield, were validated by comparison with plant data supplied by XU Ou-Guan and Hong-Ye (2006). To simulate the FCC riser, the seven-lump model involved residual oil, heavy lump, light lump, liquefied petroleum gas, gasoline, dry gas and coke (to predict the feed conversion and the product distribution) has been developed. The model helps us get good insight into the performance of an industrial riser reactor that would be useful for optimization of Fluid Catalytic Cracking.

REFERENCES

- Ali, H. and S. Rohani, 1997. Dynamic modeling and simulation of riser-type fluid catalytic cracking unit. *Chem. Eng. Tech.*, 20: 118-130. DOI: 10.1002/ceat.270200209
- Ali, H., S. Rohani and J.P. Corriou, 1997. Modeling and control of a riser type Fluid Catalytic Cracking (FCC) unit. *Trans. Inst. Chem. Eng.*, 75: 380-395. <http://cat.inist.fr/?aModele=afficheN&cpsidt=2680749>
- Ancheyta-Juarez, J., F. Lopez-Isunza and E. Aguilar-Rodriguez, 1999. 5-Lump kinetic model for gas oil catalytic cracking. *Appl. Catal. A*, 177: 227-235. DOI: 10.1016/S0926-860X(98)00262-2
- Arandes, J.M. and H.I. Lasa, 1992. Simulation and multiplicity of steady states in fluidized FCCUS. *Chem. Eng. Sci.*, 47: 2535-2540. DOI: 10.1016/0009-2509(92)87089-9

- Arbel, A., Z. Huang, I.H. Rinard, R. Shinnar and A.V. Sapre, 1995. Dynamic and control of fluidized catalytic crackers. *Ind. Eng. Chem. Res.*, 34: 3014-3026. DOI: 10.1021/ie00048a013
- Berry, T.A., T.R. McKeen, T.S. Pugsley and A.K. Dalai, 2004. Two-dimensional reaction engineering model of the riser section of a fluid catalytic cracking unit. *Ind. Eng. Chem. Res.*, 43: 5571-558. DOI: 10.1021/ie0306877
- Bollas, G., 2002. Modeling small-diameter FCC riser reactors, a hydrodynamic and kinetic approach. *Ind. Eng. Chem. Res.*, 41: 5410-5418. DOI: 10.1021/ie0202423
- Bollas, G., 2007. Five-lump kinetic model with selective catalyst deactivation for the prediction of the product selectivity in the fluid catalytic cracking process. *Catalysis Today*, 127: 31-43. DOI: 10.1016/j.cattod.2007.02.037
- Corella, J. and E. Frances, 1991. On the Kinetic Equation of Deactivation Cracking (FCC) Catalysts with Commercial Feedstocks, 68: 375-381. DOI: 10.1016/S0167-2991(08)62657-9
- Derouin, C., D. Nevicato, M. Forissier, G. Nild and J. Bernard, 1997. Hydrodynamics of riser units and their impact on fcc operation. *Ind. Eng. Chem. Res.*, 36: 4504-4515. DOI: 10.1021/ie970432r
- Dupain, X., M. Makkee and J.A. Moulijn, 2006. Optimal conditions in fluid catalytic cracking: A mechanistic approach. *Applied Catalysis*, 297: 198-219. DOI: 10.1016/j.apcata.2005.09.009
- Ellis, R.C., X. Li and J.B. Riggs, 1998. Modeling and optimization of a model IV fluidized catalytic cracking unit. *AICHE. J.*, 44: 2068-2079. DOI: 10.1002/aic.690440914
- Hagelberg, P. and I. Eilos, 2002. Kinetics of catalytic cracking with short contact times. *Applied Catalyst. A*, 223: 73-84. DOI: 10.1016/S0926-860X(01)00744-X
- Han, I.S. and C.B. Chung, 2001. Dynamic modeling and simulation of a fluidized catalytic cracking process. *Chem. Eng. Sci.*, 55: 1951-1971. DOI: 10.1016/S0009-509(00)00493-0
- Jacob, S.M., B. Gross, S.E. Voltz and V.W. Weekman, 1976. A lumping and reaction scheme for catalytic cracking, *AICHE. J.*, 22: 701-713. DOI: 10.1002/aic.690220412
- Kasat, R.B., D. Kunzru, D.N. Saraf, K. Santosh and K. Gupta, 2002. Optimization of industrial FCC units using elitist nondominated sorting genetic algorithm. *Ind. Eng. Chem. Res.*, 27: 1785-1800. DOI: 10.1016/S0098-1354(03)00153-4
- Kenny, Y.G., T.S. Pugsley and F. Berruti, 1994. Modeling the hydrodynamics of down flow gas-solids reactors. *Chem. Eng. Sci.*, 51: 2661-2666. DOI: 10.1016/0009-2509(96)00133-9
- Larocca, M., S. Ng and H. Delasa, 1990. Deactivation of cracking catalyst in short contact time reactors. *Ind. Eng. Chem. Res.*, 69: 355-360. DOI: 10.1002/cjce.5450690143
- Lee, L.S., Y.W. Chen, T.N. Huang and W.Y. Pan, 1989. Four-lump kinetic model for fluid catalytic cracking process. *Can. J. Chem. Eng.*, 67: 615-619. DOI: 10.1002/cjce.5450670414
- Martin, M.P., C. Derouin and P. Turlier, 1992. Catalytic cracking in riser reactors: Core-annulus and elbow effects. *Chem. Eng. Sci.*, 47: 2319-2327. DOI: 10.1016/0009-2509(92)87054-T
- Mu, Z. and J. Wang, 2003. Optimum design of radial flow moving-bed reactors based on a mathematical hydrodynamic model. *Chem. Eng. Process.*, 42: 409-417. DOI: 10.1016/S0255-2701(02)00065-X
- Oliveira, L. and E.C. Biscaia., 1989. Catalytic cracking kinetic models. parameter estimation and model evaluation. *Ind. Eng. Chem. Res.*, 28: 264-271. DOI: 10.1002/aic.690470416
- Ou-Guan, X.U. and S.U. Hong-Ye, 2006. 7-lump kinetic model for residual cracking. *J. Zhejiang Univ. Sci. A.*, 7: 1932-1941. DOI: 0.1631/jzus.2006.A1932
- Pugsley, S. and K. Dalai, 2004. Two-dimensional reaction engineering model of the riser section of fluid catalytic cracking unit. *Ind. Eng. Chem. Res.*, 43: 5571-5581. DOI: 10.1021/ie0306877
- Theologos, K.N. and N.C. Markatos, 1993. Advanced modeling of fluid catalytic cracking riser-type reactors. *AICHE. J.*, 39: 1007-1017. DOI: 10.1002/aic.690390610
- Weekman, V., 1968. A model of catalytic cracking conversion in fixed, moving and fluid-bed reactors. *Ind. Eng. Chem. Proc. Des.*, 7: 90-95. DOI: 10.1021/i260025a018
- Yen, P. and S.W. Yu, 1988. Fluidized-bed catalyst cracking regenerator modelling and analysis., 2: 71-82. DOI: 10.1016/0300-9467(89)80048-6